

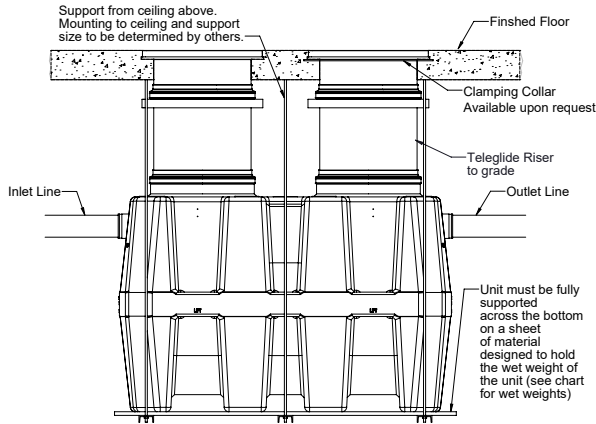

SUSPENDED UNIT INSTALLATION INSTRUCTIONS

**SUSPENDED UNIT INSTALLATION DETAIL
ACCESSED FROM FLOOR ABOVE**



**SUSPENDED UNIT INSTALLATION DETAIL
ACCESSED FROM SAME FLOOR**

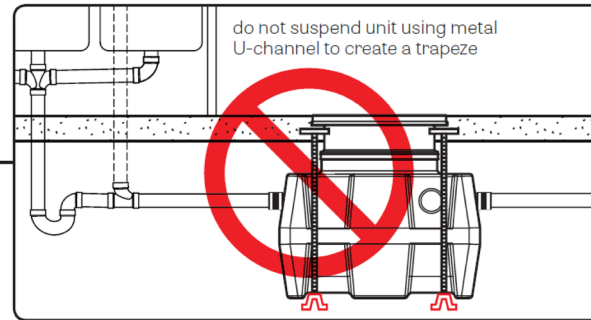
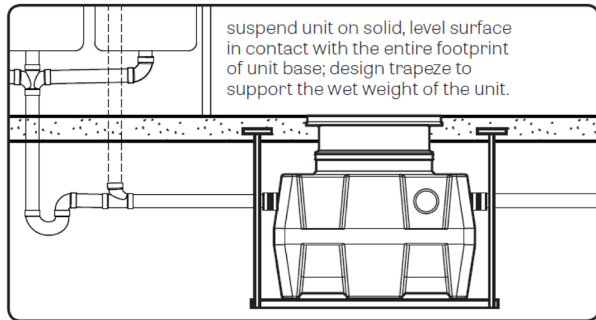
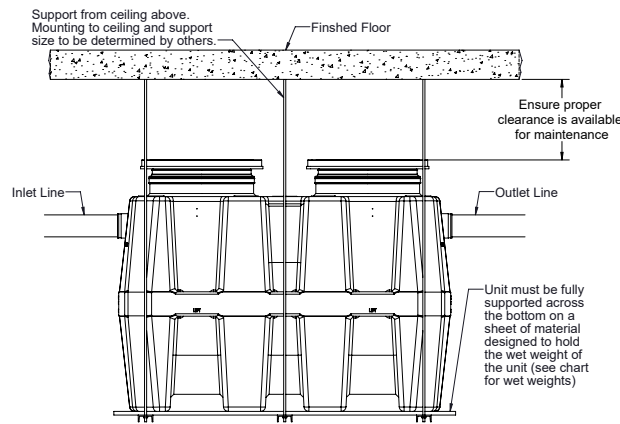

913-222-1500

HELP@STRIEMCO.COM

STRIEMCO.COM

CUSTOMER SERVICE HOURS: Mon-Fri, 8 am - 5 pm CST

OIL SEPARATOR

UNIT	WET WEIGHT (lbs)
15	153
25	206
35	394
50	567
75	1047
100	2315

PS-S

UNIT	WET WEIGHT (lbs)
15	155
25	210
35	400
50	575
75	1057
100	2355

CB-S

UNIT	WET WEIGHT (lbs)
50	567
125	1047
275	2315

CB-G

UNIT	WET WEIGHT (lbs)
50	662
125	1130

AARDVARK™

UNIT	WET WEIGHT (lbs)
SMALL	167
MEDIUM	400
LARGE	580
X-LARGE	1060

BIO BASIN

UNIT	WET WEIGHT (lbs)
275	2315

LAB BASIN™

UNIT	WET WEIGHT (lbs)
15	153
25	206
35	394
50	567
125	1047
275	2315

MARKET SPECIFIC

UNIT	WET WEIGHT (lbs)
CB-50-SFL	633
CB-125-SFL	1107
CB-275-SFL	2419
FLI-125	1047
FLI-275	2415
OCT-50	543
OCT-125	1047
OCT-275	2315
SI-UPC-1016	1047