

SPECIFICATIONS

1. Max flow rate: 314 GPM.
2. Liquid capacity: 1615 Gallons (215.8 cu. ft.)
3. Oil capacity: 1231 Gallons.
4. Unit weight: 1800 lbs.
5. H2O rated cast iron covers.
6. Maximum operating temperature 140°F continuous.

NOTES

1. 7/8" thick high density polyethylene walls.
2. Unit supplied with built-in adapter(s) for up to 5" of adjustability. Additional riser(s) available for deeper burial depth.
3. For buried applications.
4. Lifting lug set included for easy install.

ENGINEER SPECIFICATION GUIDE

Striem oil separator model OS-1600-WCCS shall be lifetime guaranteed and made in USA of High Density Polyethylene with minimum 7/8" uniform wall thickness. Separator shall be furnished for below grade installation with field adjustable riser system. Separator flow rate shall be 314 GPM. Separator oil capacity shall be 1231 gallons. Covers shall provide water/gas-tight seal and have a maximum 16,000 lbs load capacity.

OPTIONS

- 4M** - 4" Male Thread Inlet / Outlet
- 4P** - 4" Plain End Inlet / Outlet

RISER OPTIONS

- Included:** 0" - 5"
- SR24** (3): >5" - 24"
- LR24** (3): >24" - 39"
- SR24** (6): >39" - 43"
- SR24** (3) + **LR24** (3): >43" - 58"
- LR24** (6): >58" - 72"
- SR24** (3) + **LR24** (6): >72" - 90"
- LR24** (9): >90" - 106"

ADDITIONAL OPTIONS

- HDK-9:** High Water Table Hold Down Kit

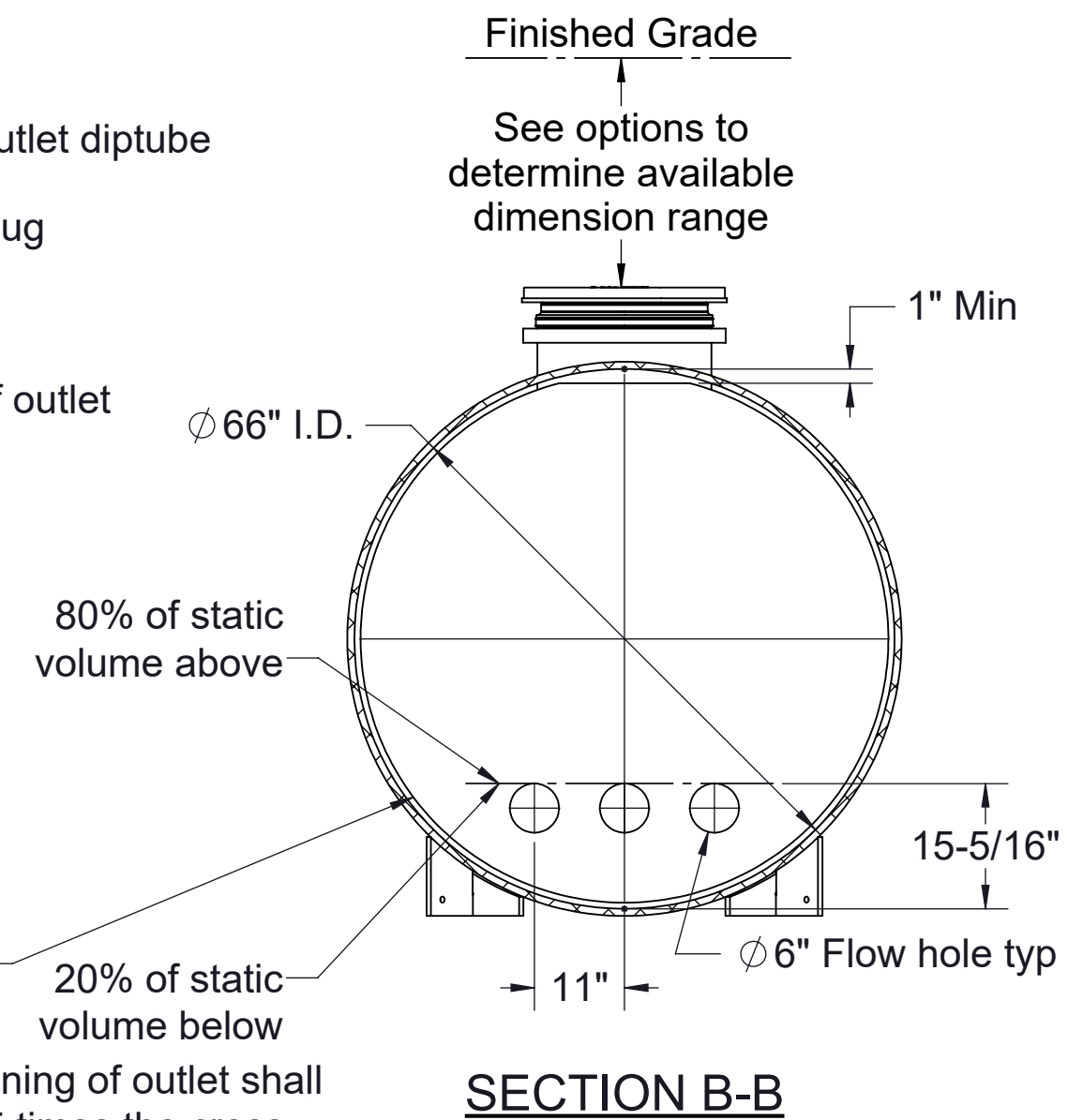
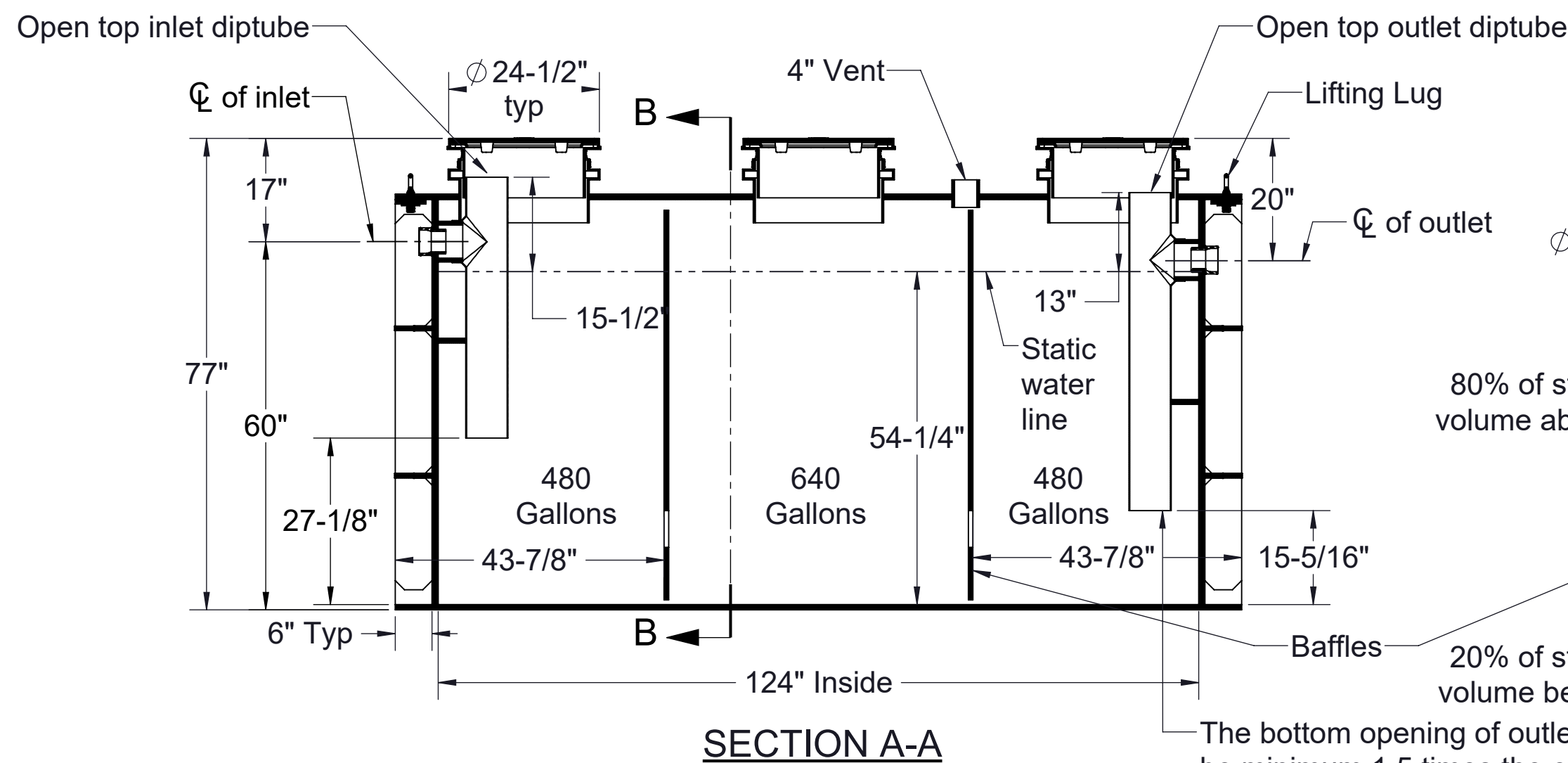
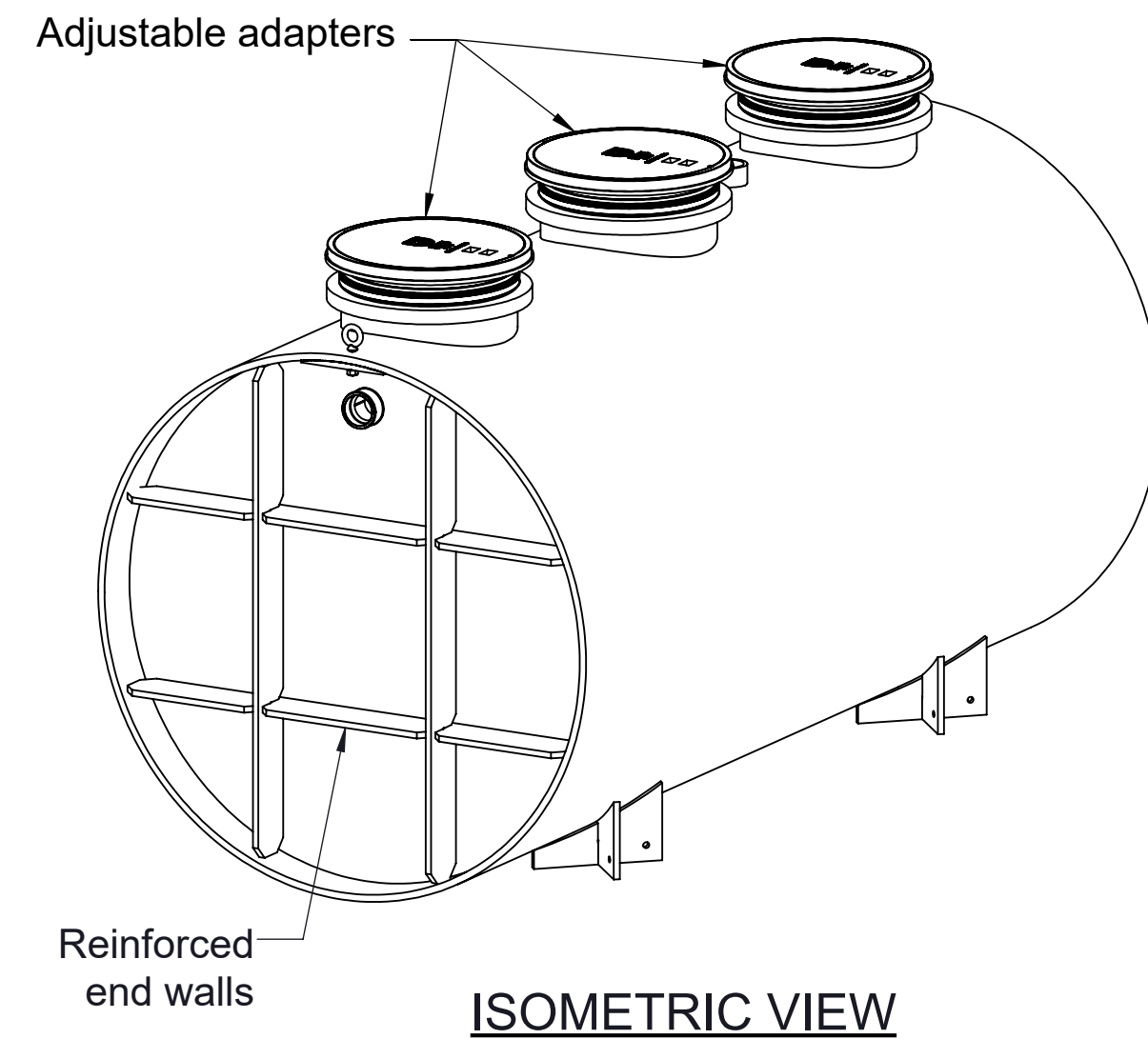
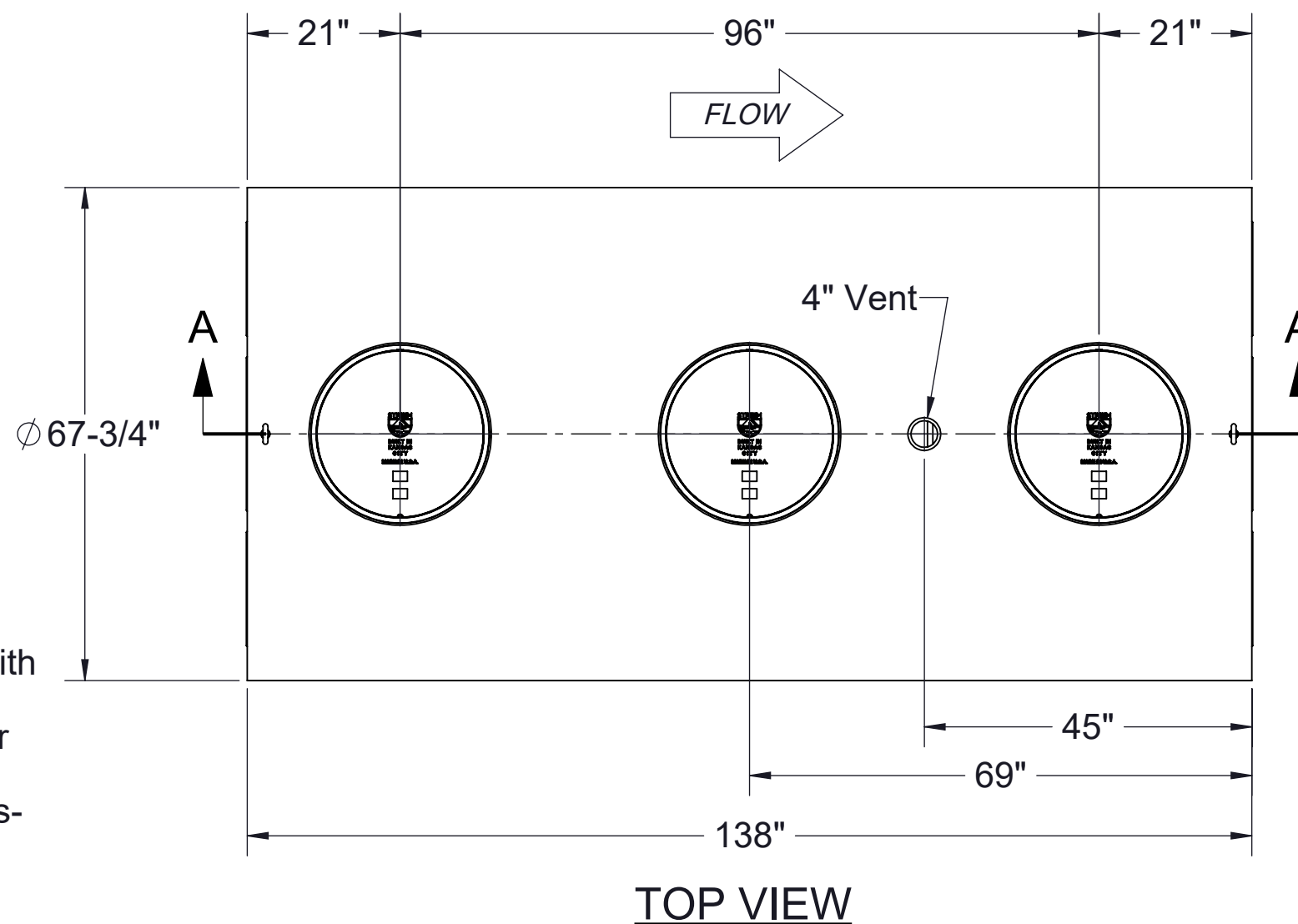

Signature of Approval: _____
 Company: _____
 Date of Approval: _____
 Specifying Engineer: _____
 Engineering Firm: _____

PO IS NON-CANCELABLE
 ORDER IS NON-RETURNABLE

Approved by WSSC

MODEL NUMBER: OS-1600-WSSC			
DESCRIPTION: POLYETHYLENE OIL SEPARATOR 314 GPM 1615 GALLON CAPACITY			
DWG BY: ENG	DATE: 12/1/22	REV: 0	ECO:

SPECIFICATION SHEET

Striem
 3100 Brinkerhoff
 Kansas City, KS 66115
 Tel: 913-222-1500
 orders@striemco.com
 www.striemco.com



Made in the U.S.A