



LAB RAT™ NEUTRALIZATION TANKS

Installation, Operation, & Maintenance Guide

WHAT'S INCLUDED

LB-2

- (1) LB-2 tank with (3) integral 2" FPT connections
- (1) Gasketed cover with (3) captive thumb screws
- (2) 2" MPT x 1-1/2" FPT adapters
- (1) 2" MPT plug

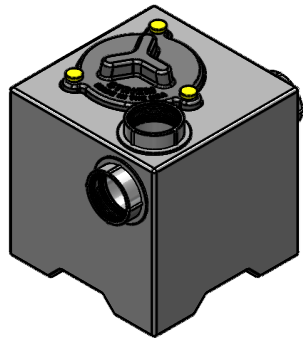

LB-2
LAB RAT™
2 GALLON
NEUTRALIZATION TANK

LB-2-ADA

- (1) LB-2-ADA tank with (2) integral 2" FPT connections
- (1) Gasketed 3" cleanout accessway
- (2) 2" MPT x 1-1/2" FPT adapters

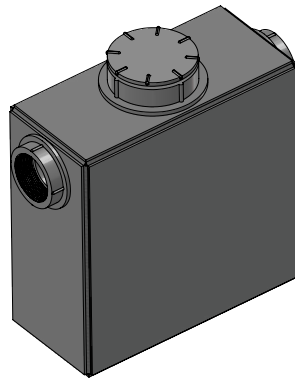

LB-2-ADA
LAB RAT™
2 GALLON
NEUTRALIZATION TANK

LB-5

- (1) LB-5 tank with (4) integral 2" FPT connections
- (1) Gasketed cover with (3) captive thumb screws
- (2) 2" MPT x 1-1/2" FPT adapters
- (2) 2" MPT plug

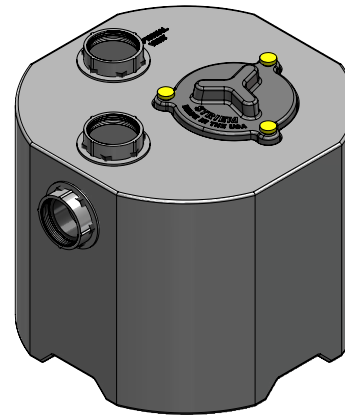

LB-5
LAB RAT™
5 GALLON
NEUTRALIZATION TANK

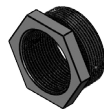

2" MPT x 1-1/2" FPT Adapter

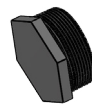

2" MPT Plug

OVERVIEW

Striem Lab Rat™ Neutralization Tanks are intended for installation under individual sinks, lab stations, and other point-of-use locations. They are designed to bring wastewater to an acceptable state for local wastewater treatment facilities through neutralization or dilution.

OPERATION

Low pH wastewater enters through the inlet connection and is directed to the bottom of the unit through the inlet diptube. As the wastewater moves through the unit, its pH is raised through dilution with neutral water, or neutralization through limestone media. The polyethylene construction makes the Lab Rat™ an ideal vessel for chemical waste applications. Striem Lab Rat™ tanks have a built in sewer gas trap; check with local codes to ensure compliance.

LIFETIME WARRANTY

Our products are designed to last the lifetime of the plumbing system in which they are installed. If they don't, we will repair or replace them at no charge. Product damage due to normal wear and tear may be repaired or replaced at a reasonable charge.



☎ 913-222-1500 ✉ HELP@STRIEMCO.COM 🌐 STRIEMCO.COM

CUSTOMER SERVICE HOURS: Mon-Fri, 8 am - 5 pm CST

INSTALLATION

Always install and maintain Neutralization Tanks according to manufacturer's recommendations, specifier requirements, and state and/or local codes.

- 1 Inspect the unit for defects and make sure it meets specifier requirements. Make sure no damage has been done to the tank or fittings during transportation.
- 2 Lab Rat™ tanks are designed for above grade installation only. Install the tank as close to the fixture as possible, making sure there is enough room above and around the tank for proper cleaning and maintenance.
- 3 All Tanks must be independently supported to avoid stress on fitting connections.
- 4 Lab Rat™ ships ready to use the 2" connections. To use the 1-1/2" connections, apply Teflon tape or pipe sealant to adapters, then install the fittings.
- 5 Connect piping to the Inlet and Outlet with appropriate piping material, supplied by others. Do not over tighten fittings. The Lab Rat™ has a built in sewer gas trap, eliminating the need for an additional trap prior to the tank, if local code allows.
- 6 On applicable units, plug unused Inlet. If top Inlet is used, plug side Inlet. If side Inlet is used, plug top Inlet.
- 7 The LB-5 comes with an optional vent on the top of the tank. If unused, ensure the connection is plugged.
- 8 Inspect all pipe joints to ensure there are no leaks.
- 9 If using limestone, add to empty tank.
- 10 Fill unit with water.
- 11 Inspect the cover gasket and fasten cover to tank.
- 12 System is now ready for use.

LB-2 INSTALLATION

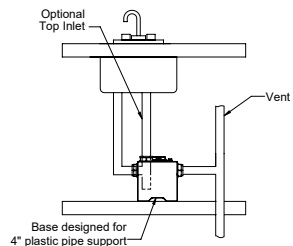

LB-2-ADA INSTALLATION

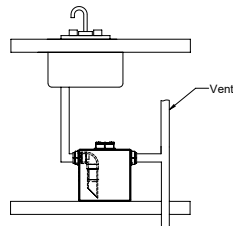

LB-2-ADA INSTALLATION
(side view)

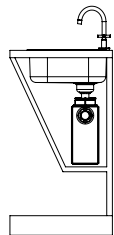

LB-5 INSTALLATION
showing 4" plastic pipe support
(by others).

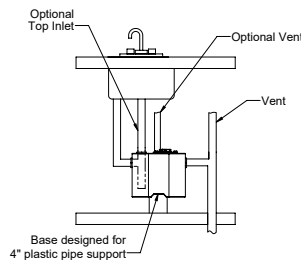

LIMESTONE

When using limestone as a neutralizing agent, it is essential to use the correct size and type of limestone. Striem recommends limestone that is 2" to 3" in size and has a Calcium Carbonate content of 90% or greater (Striem offers limestone that meets these requirements).

MAINTENANCE

For the best maintenance, contact a local sewer and drain contractor.

- 1 Always take proper care to ensure a safe and healthy environment while maintaining the neutralization tank.
- 2 Remove cover.
- 3 Remove all contents of the neutralization tank, including wastewater, sludge, sediment, and limestone (if used).
- 4 Clean the drain line and diptube of all debris.
- 5 Replace limestone, if used. A qualified professional should be responsible for the analysis of effluent, inspection, maintenance and replacement of neutralizing agent.
- 6 Inspect cover gasket for wear and tear and fasten cover to tank.
- 7 Dispose of contents per local code.

MAINTENANCE FREQUENCY

Maintenance frequency depends on the quality and contents of the chemical waste passing through the system. Striem recommends inspecting the Lab Rat™ every one to three months until a proper maintenance schedule can be established.

Debris and sludge must be cleaned out periodically to allow the free flow of wastewater through the unit. If it is determined that the system will encounter large amounts of solids, specify a Striem solids interceptor.

TROUBLESHOOTING TIPS



Slower than usual drainage may indicate a blockage and a need to maintain the neutralization tank. Ensure the drain line and diptube is cleared of all debris in the presence of slow drainage.

Effluent flow of high pH may indicate that the Lab Rat™ neutralization agent has been depleted. In the presence of high pH effluent, maintain the unit immediately.

NOTES

Striem Lab Rats™ are not to be installed in any other manner except as shown. Consult local codes for separate trapping requirements, cleanout locations and additional installation instructions.



913-222-1500



HELP@STRIEMCO.COM



STRIEMCO.COM

CUSTOMER SERVICE HOURS: Mon-Fri, 8 am - 5 pm CST