

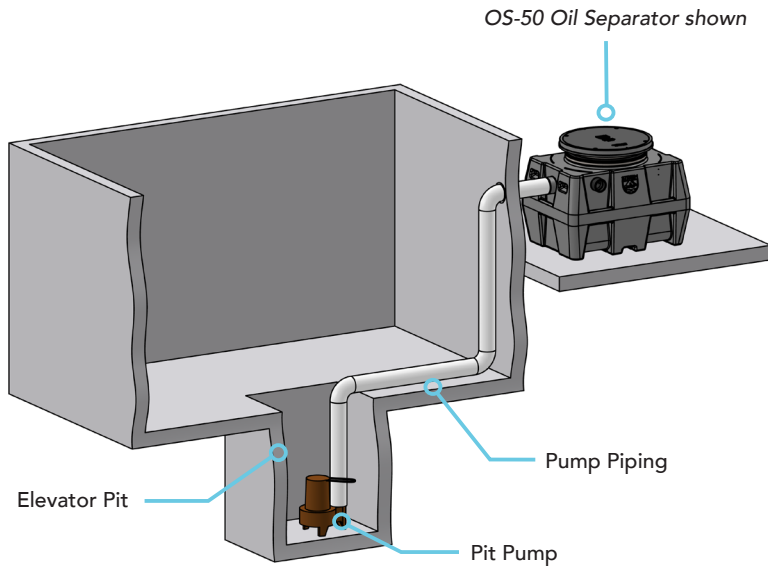

OIL/WATER SEPARATOR REQUIREMENT STATE OF MASSACHUSETTS HYDRAULIC ELEVATOR SUMPS



COMMONWEALTH OF MASSACHUSETTS ADVISORY REGARDING ELEVATOR SUMPS ADOPTED DECEMBER 4, 2019

"Discharge from gravity drains or pumps entering the sanitary or storm drainage system shall comply with the requirements of 248 CMR 10.00. Elevators utilizing hydraulic oil or other petroleum distillates which may be harmful to the sanitary or storm drainage system shall discharge through a properly sized oil/water separator installed in compliance with 248 CMR 10.09."

NOTE: Oil detecting pumps in lieu of an oil separation system are prohibited.

SIZING

Striem recommends sizing the oil separator based on the flow rate of the sump pump(s). (50 GPM per pump)

# ELEVATORS	PIPE SIZE	SELECTION
1	2" / 3" / 4"	OS-50
	6"	OS-75
2	4" / 6"	OS-100

ADDITIONAL OPTIONS

- Coalescing Media
- Oil Level Monitoring System
- Field-Adjustable Risers

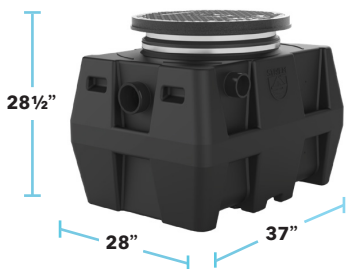

OS-50

CONNECTIONS: 4"
MAX FLOW RATE: 50 GPM
LIQUID CAPACITY: 57 GAL.
OIL CAPACITY: 40 GAL.
MA APPROVAL CODE: P3-0716-588

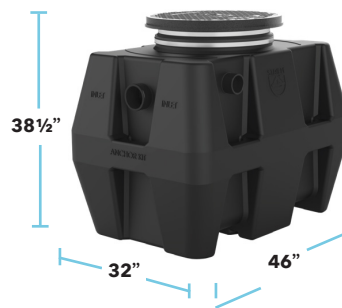

OS-75

CONNECTIONS: 4", 6" OPTIONAL
MAX FLOW RATE: 75 GPM
LIQUID CAPACITY: 110 GAL.
OIL CAPACITY: 93 GAL.
MA Approval Code: P3-0716-588

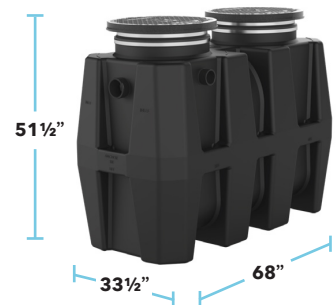

OS-100

CONNECTIONS: 4", 6" OPTIONAL
MAX FLOW RATE: 100 GPM
LIQUID CAPACITY: 250 GAL.
OIL CAPACITY: 144 GAL.
MA Approval Code: P3-0716-588

(All models stocked locally in Massachusetts)

913-222-1500 HELP@STRIEMCO.COM

STRIEMCO.COM



LOCAL REP: Futura Sales

CONTACT: 508-788-9257 | info@futuresales.com

