

SPECIFICATIONS

1. 6" Plain End inlet/outlet shown, 3" Plain End vents standard.
2. Liquid capacity: 1000 gallons (133 cu. ft.).
3. Flammable liquid capacity: 370 gallons.
4. Solids capacity: 477 gallons.
5. Unit weight w/ standard covers: 1144 lbs.; w/ cast iron covers: 1324 lbs.
6. Maximum operating temperature 140°F continuous.

NOTES

1. For gravity drainage applications only.
2. Do not use for pressure applications.
3. Cover placement allows full access to tank for proper maintenance.
4. Lifting lug set for easy install.

ENGINEER SPECIFICATION GUIDE

Striem flammable liquid interceptor model FLI-1000 shall be lifetime guaranteed and made in the USA. Interceptor shall be constructed of polyethylene with 7/8" nominal wall thickness. Interceptor shall be manufactured for below-grade installation. Field-adjustable riser system is available as an option to bring manhole covers to grade. Interceptor liquid holding capacity shall be 1000 gallons and flammable liquid capacity shall be 370 gallons. Solids capacity shall be 477 gallons. Covers shall provide water/gas-tight seal and have a maximum 16,000 lbs. load capacity.

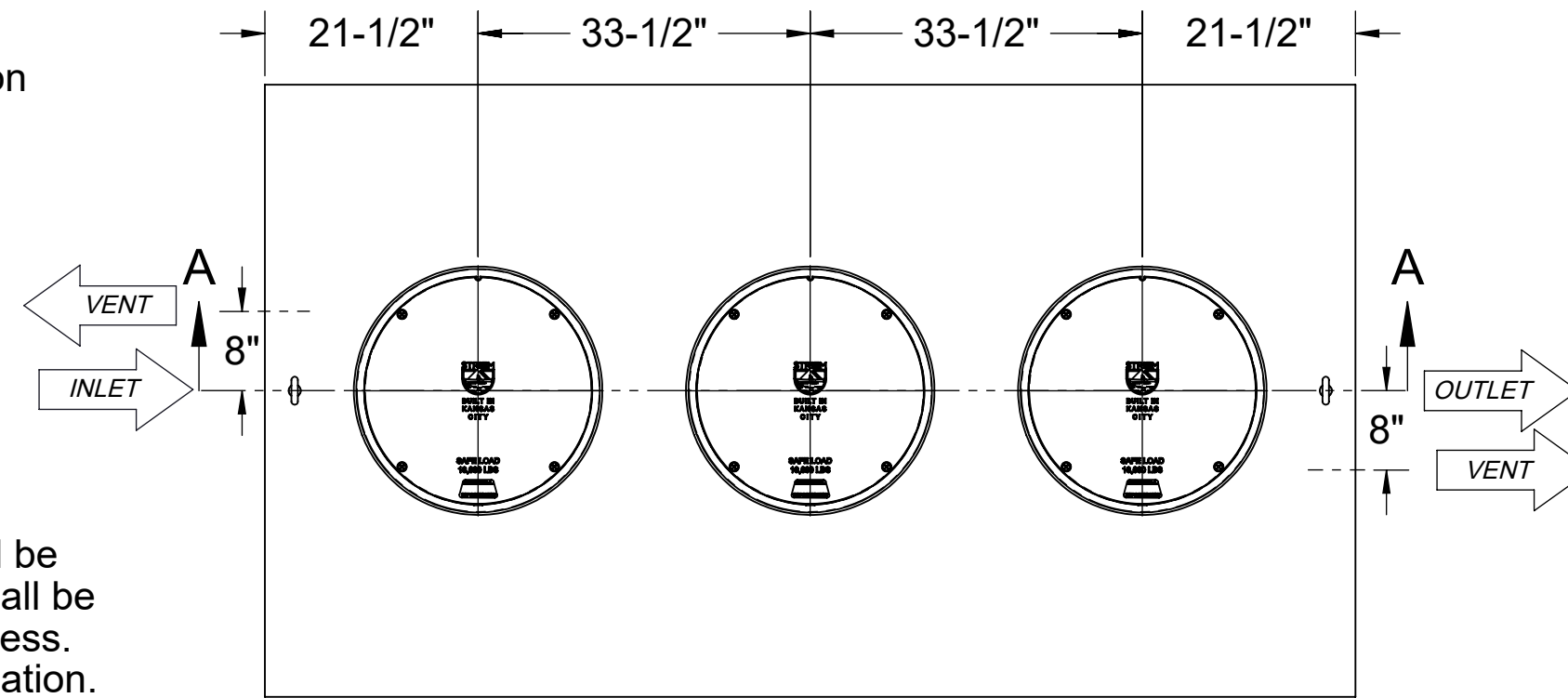

TOP VIEW

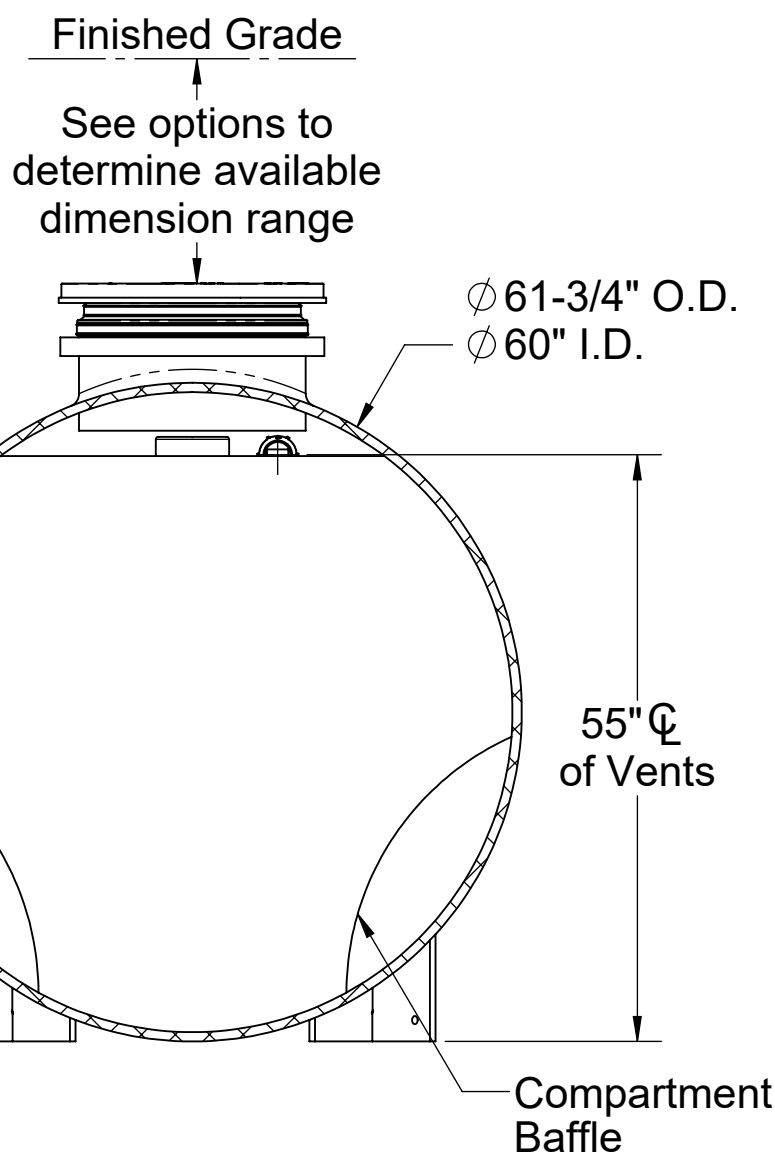

SECTION B-B

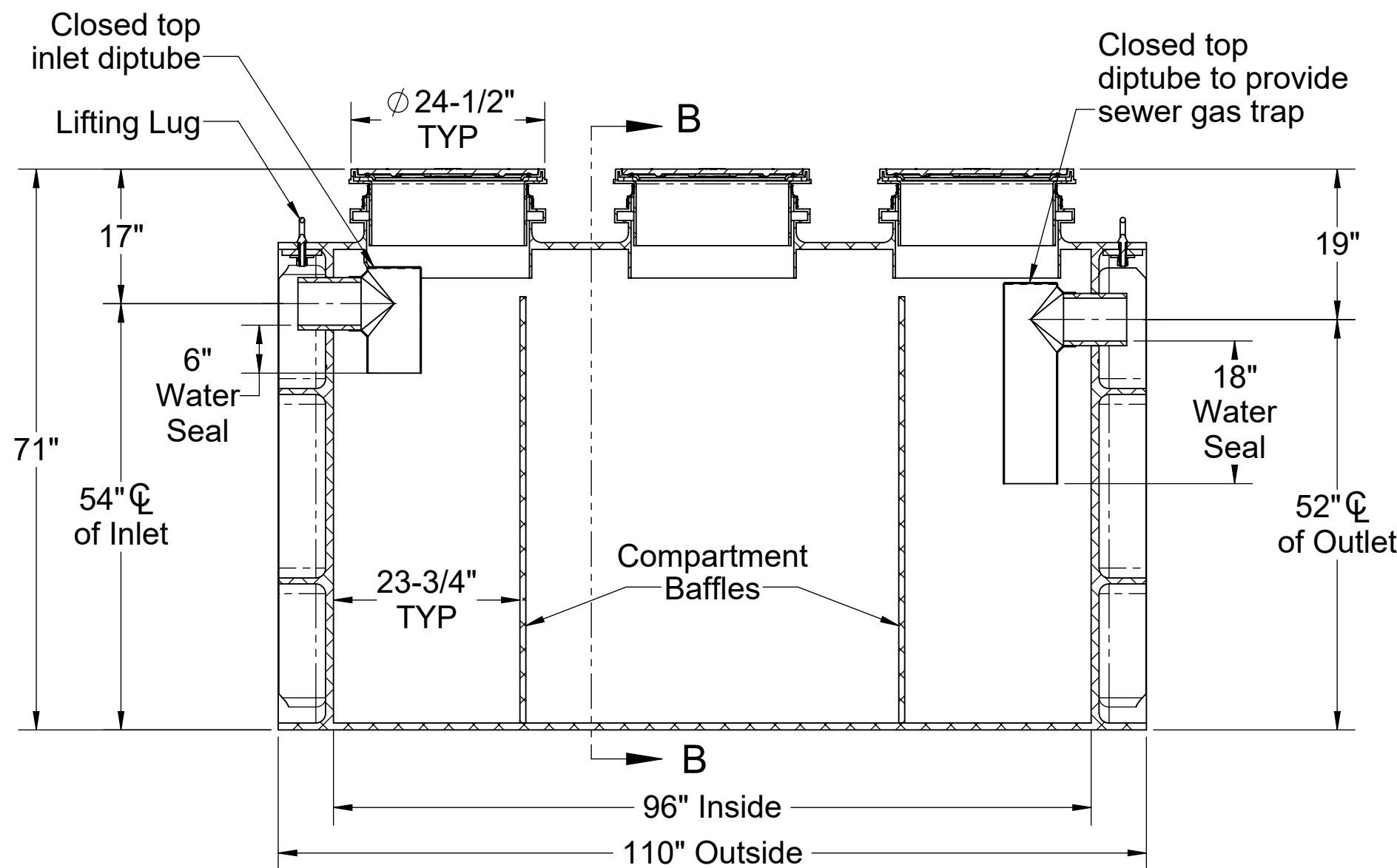

SECTION A-A

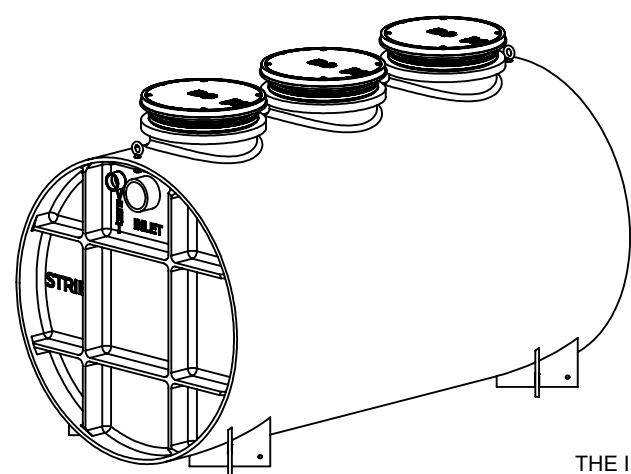

PO IS NON-CANCELABLE ORDER IS NON-RETURNABLE

PROPRIETARY AND CONFIDENTIAL
THE INFORMATION CONTAINED IN THIS DRAWING IS THE SOLE PROPERTY OF STRIEM, LLC. ANY REPRODUCTION IN PART OR AS A WHOLE WITHOUT THE WRITTEN PERMISSION OF STRIEM, LLC. IS PROHIBITED.

OPTIONS

Connection Options (Plain End Only)

Size

- 4"
- 6"
- 8"

SELECTION REQUIRED

Riser Options

From Factory: Up to 5"

- Up to 24": **SR24** (3)
- Up to 39": **LR24** (3)
- Up to 43": **SR24** (6)
- Up to 58": **SR24** (3) + **LR24** (3)
- Up to 72": **LR24** (6)
- Up to 90": **SR24** (3) + **LR24** (6)
- Up to 106": **LR24** (9)

- OR -

- CPRK** (3): 11" - 106" (See specification for more detail.)

Additional Options

- HDK-5**: High Water Table Hold Down Kit
- C24-HP** (3): H2O Rated Pickable Cast Iron Covers
- SS**: Slick Stick™ Oil Level Monitoring System*

*Monitoring system will raise covers by 3".

MODEL NUMBER: FLI-1000

DESCRIPTION:
POLYETHYLENE
FLAMMABLE LIQUID INTERCEPTOR
1000 GALLON CAPACITY
UNRATED

DWG BY: ENG **DATE:** 8/22/2023 **REV:** 1

SPECIFICATION SHEET

Striem
Kansas City, KS
Tel: 913-222-1500
orders@striemco.com
www.striemco.com

Made in the U.S.A

