

**SPECIFICATIONS**

1. 6" Plain End inlet/outlet shown, 3" Plain End vents standard.
2. Liquid capacity: 750 gallons (100 cu. ft.).
3. Flammable liquid capacity: 323 gallons.
4. Solids capacity: 295 gallons.
5. Unit weight w/ standard covers: 1113 lbs.; w/ cast iron covers: 1293 lbs.
6. Maximum operating temperature 140°F continuous.

**NOTES**

1. For gravity drainage applications only.
2. Do not use for pressure applications.
3. Cover placement allows full access to tank for proper maintenance.
4. Lifting lug set for easy install.

**ENGINEER SPECIFICATION GUIDE**

Striem flammable liquid interceptor model FLI-750 shall be lifetime guaranteed and made in the USA. Interceptor shall be constructed of polyethylene with 7/8" nominal wall thickness. Interceptor shall be manufactured for below-grade installation. Field-adjustable riser system is available as an option to bring manhole covers to grade. Interceptor liquid holding capacity shall be 750 gallons and flammable liquid capacity shall be 323 gallons. Solids capacity shall be 295 gallons. Covers shall provide water/gas-tight seal and have a maximum 16,000 lbs. load capacity.

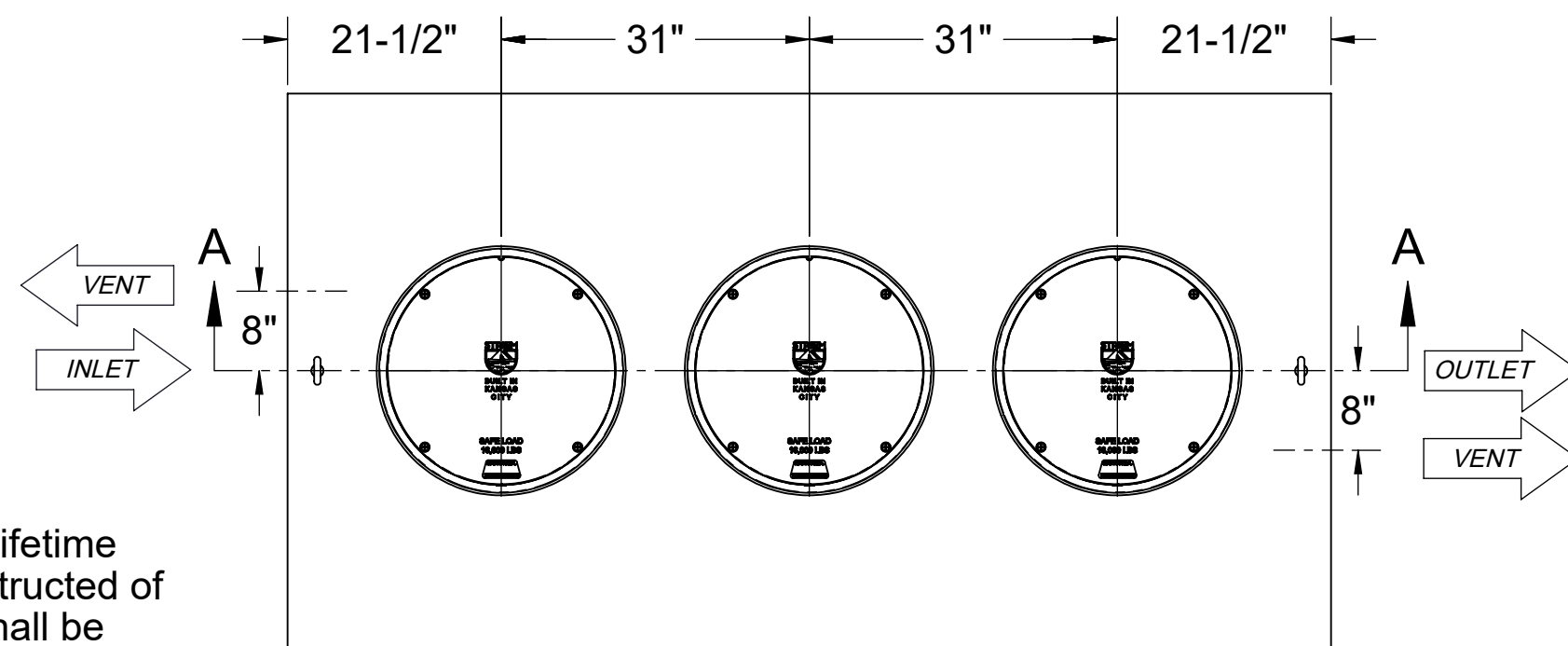

**TOP VIEW**

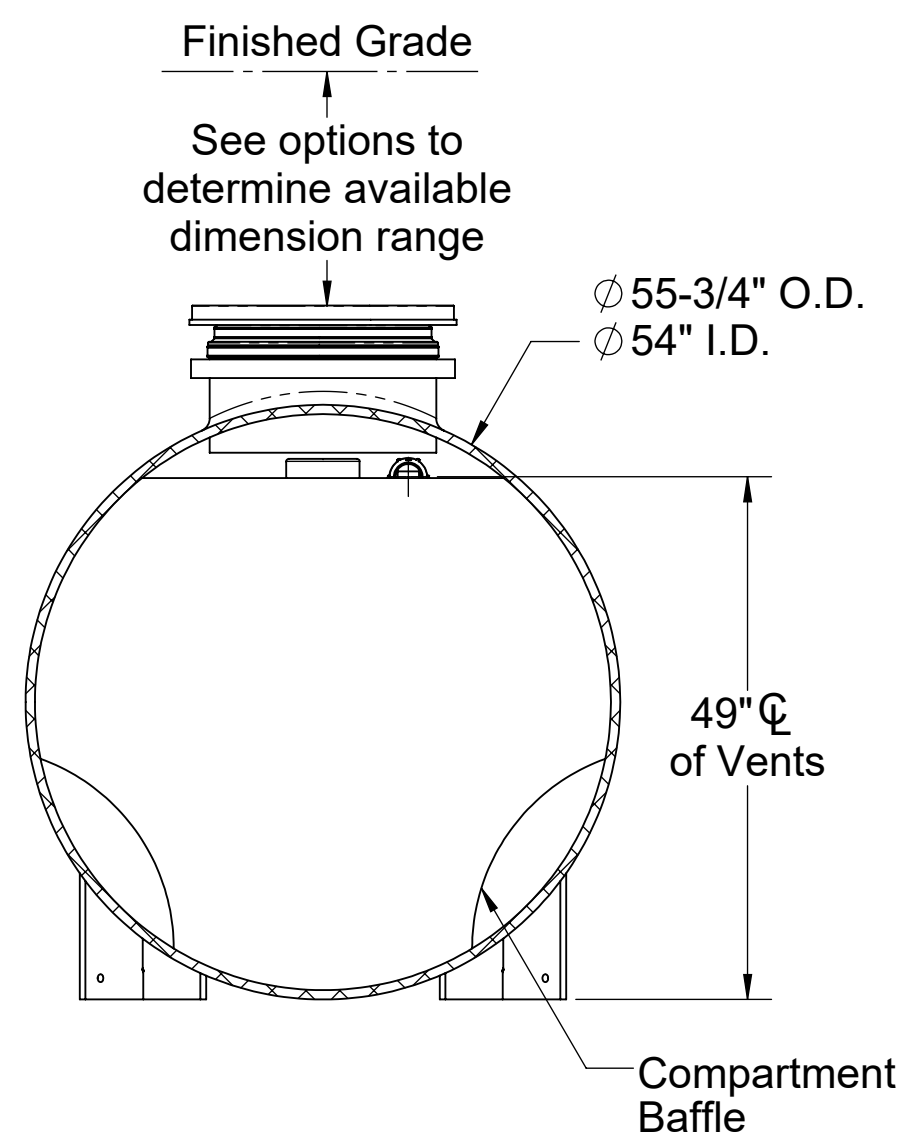

**SECTION B-B**

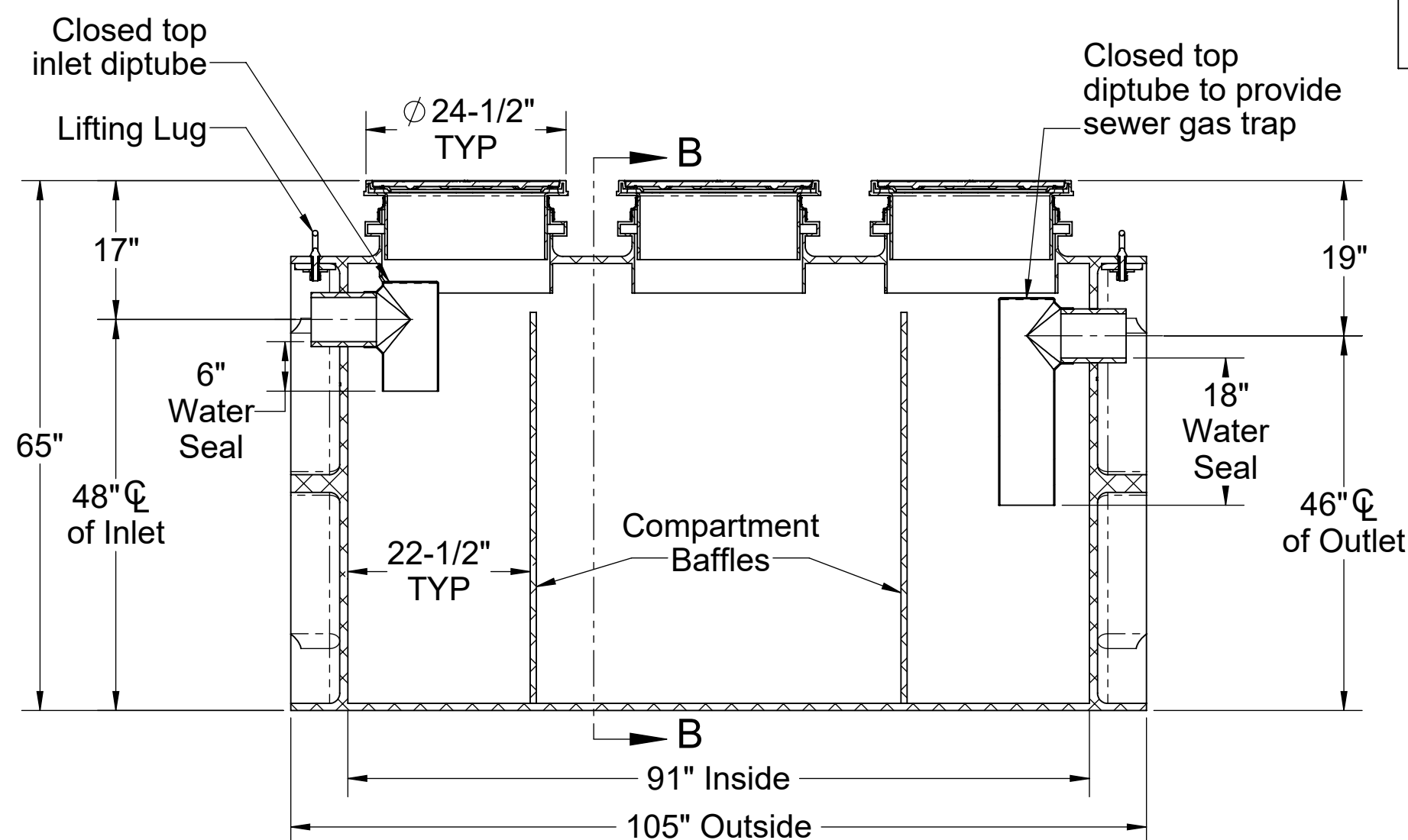

**SECTION A-A**

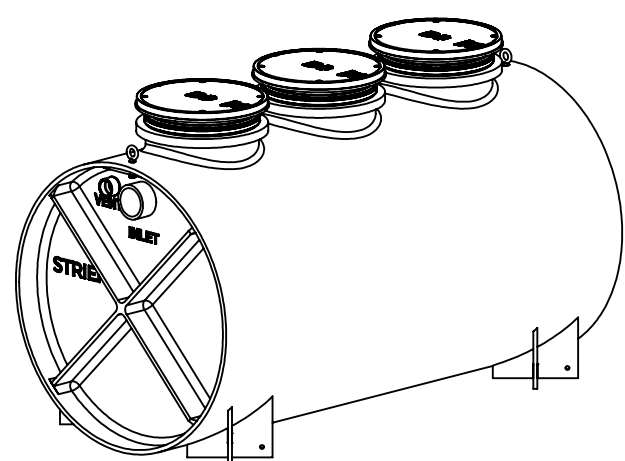

**PO IS NON-CANCELABLE  
ORDER IS NON-RETURNABLE**

**PROPRIETARY AND CONFIDENTIAL**  
THE INFORMATION CONTAINED IN THIS DRAWING IS THE SOLE PROPERTY OF STRIEM, LLC.  
ANY REPRODUCTION IN PART OR AS A WHOLE WITHOUT THE WRITTEN PERMISSION OF STRIEM, LLC. IS PROHIBITED.

**OPTIONS**

**Connection Options (Plain End Only)**

- Size**
- 4"
  - 6"
  - 8"

**SELECTION REQUIRED**

**Riser Options**

**From Factory: Up to 5"**

- Up to 24": **SR24** (3)
- Up to 39": **LR24** (3)
- Up to 43": **SR24** (6)
- Up to 58": **SR24** (3) + **LR24** (3)
- Up to 72": **LR24** (6)
- Up to 90": **SR24** (3) + **LR24** (6)
- Up to 106": **LR24** (9)

**- OR -**

- CPRK** (3): 11" - 106" (See specification for more detail.)

**Additional Options**

- HDK-4**: High Water Table Hold Down Kit
- C24-HP** (3): H2O Rated Pickable Cast Iron Covers
- SS**: Slick Stick™ Oil Level Monitoring System\*

\*Monitoring system will raise covers by 3".

**MODEL NUMBER:** FLI-750

**DESCRIPTION:**  
POLYETHYLENE  
FLAMMABLE LIQUID INTERCEPTOR  
750 GALLON CAPACITY  
UNRATED

**DWG BY:** ENG    **DATE:** 6/29/2023    **REV:** 1

**SPECIFICATION SHEET**

Striem  
Kansas City, KS  
Tel: 913-222-1500  
orders@striemco.com  
www.striemco.com

Made in the U.S.A

