

SPECIFICATIONS

1. 3" Plain end vents standard.
2. Liquid capacity: 750 gallons (100 cu. ft.).
3. Solids capacity: 295 gallons.
4. Unit weight with composite cover: 1113 lbs.
5. Maximum operating temperature 140°F continuous.
6. Highway rated covers: 16,000 lb. load rating.

NOTES

1. For gravity drainage applications only. Do not use for pressure applications.
2. Cover placement allows full access to tank for proper maintenance.
3. Lifting lug set for easy install.
4. For below grade installation only.

ENGINEER SPECIFICATION GUIDE

Striem Settler™ catch basin model CB-750-S shall be lifetime guaranteed and made in USA of High Density Polyethylene with minimum 7/8" uniform wall thickness. Tank shall be furnished for below grade installation with field adjustable riser system. Solids capacity shall be 295 gallons. Cover shall provide water/gas-tight seal and have a maximum 16,000 lbs load rating.

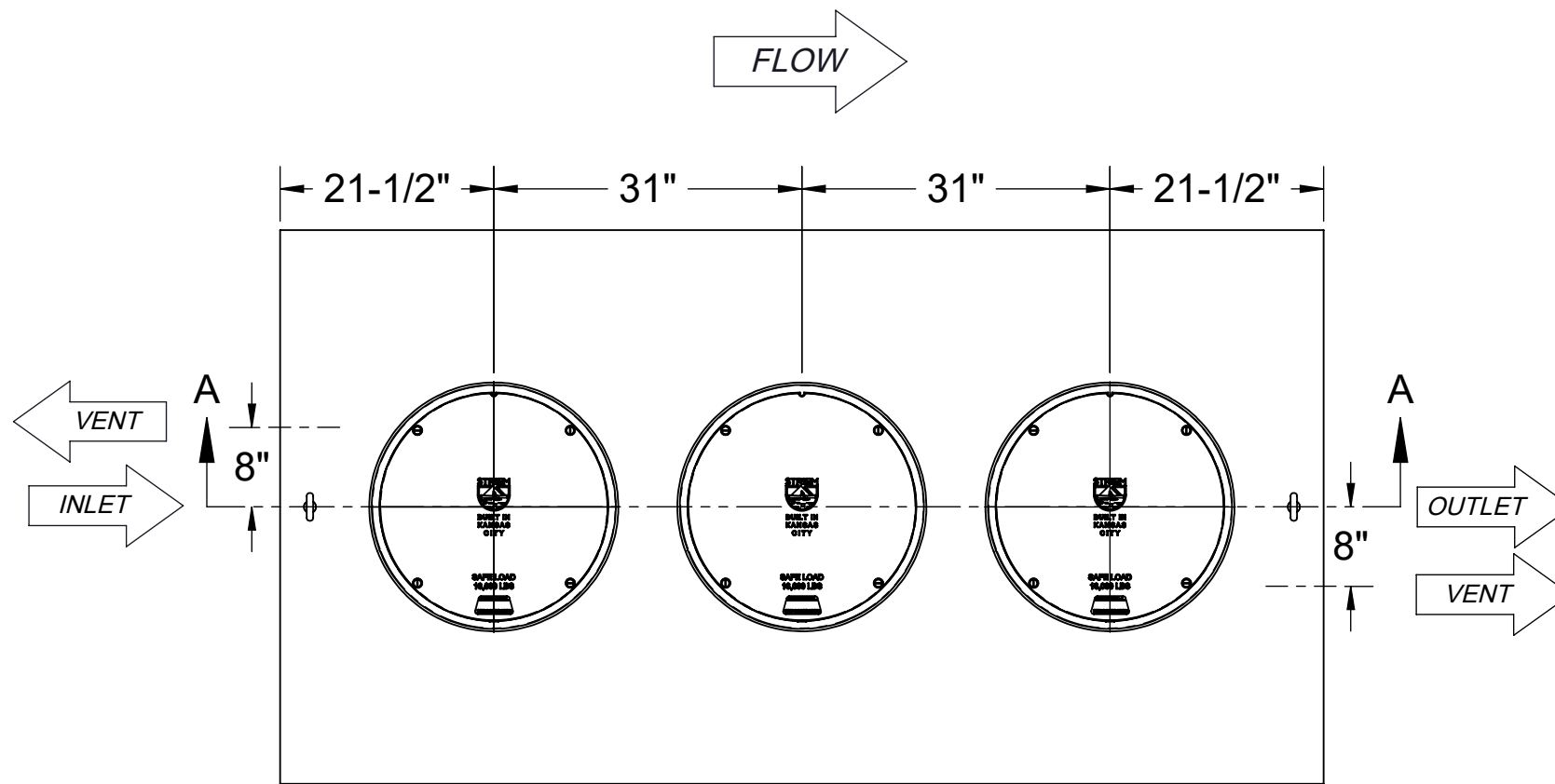

TOP VIEW

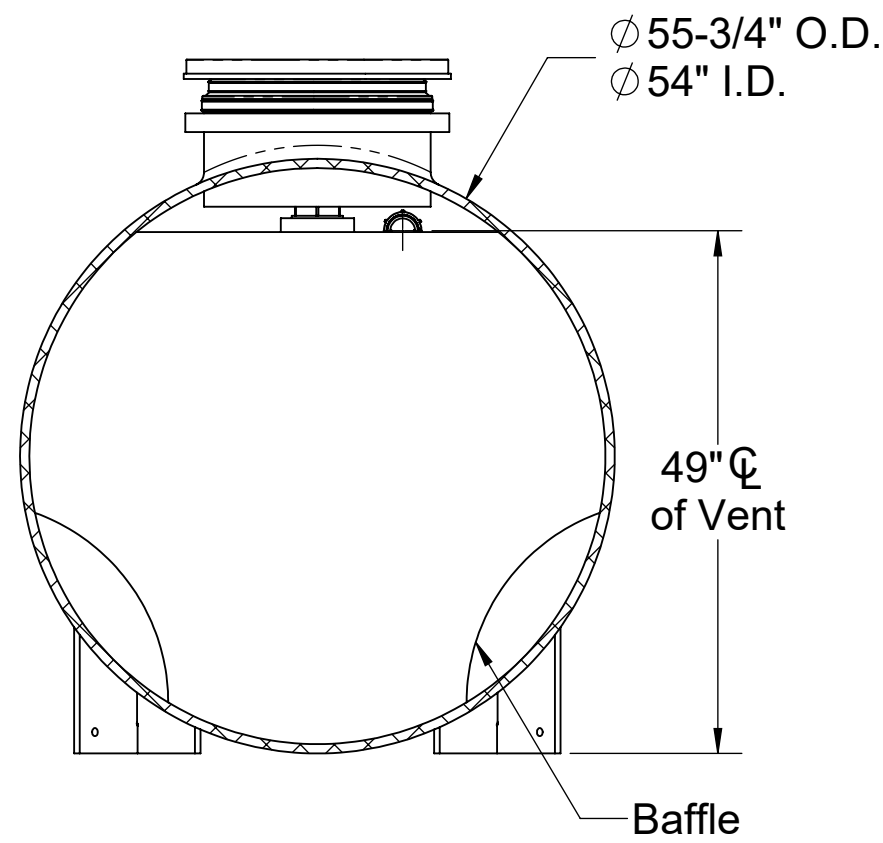

SECTION B-B

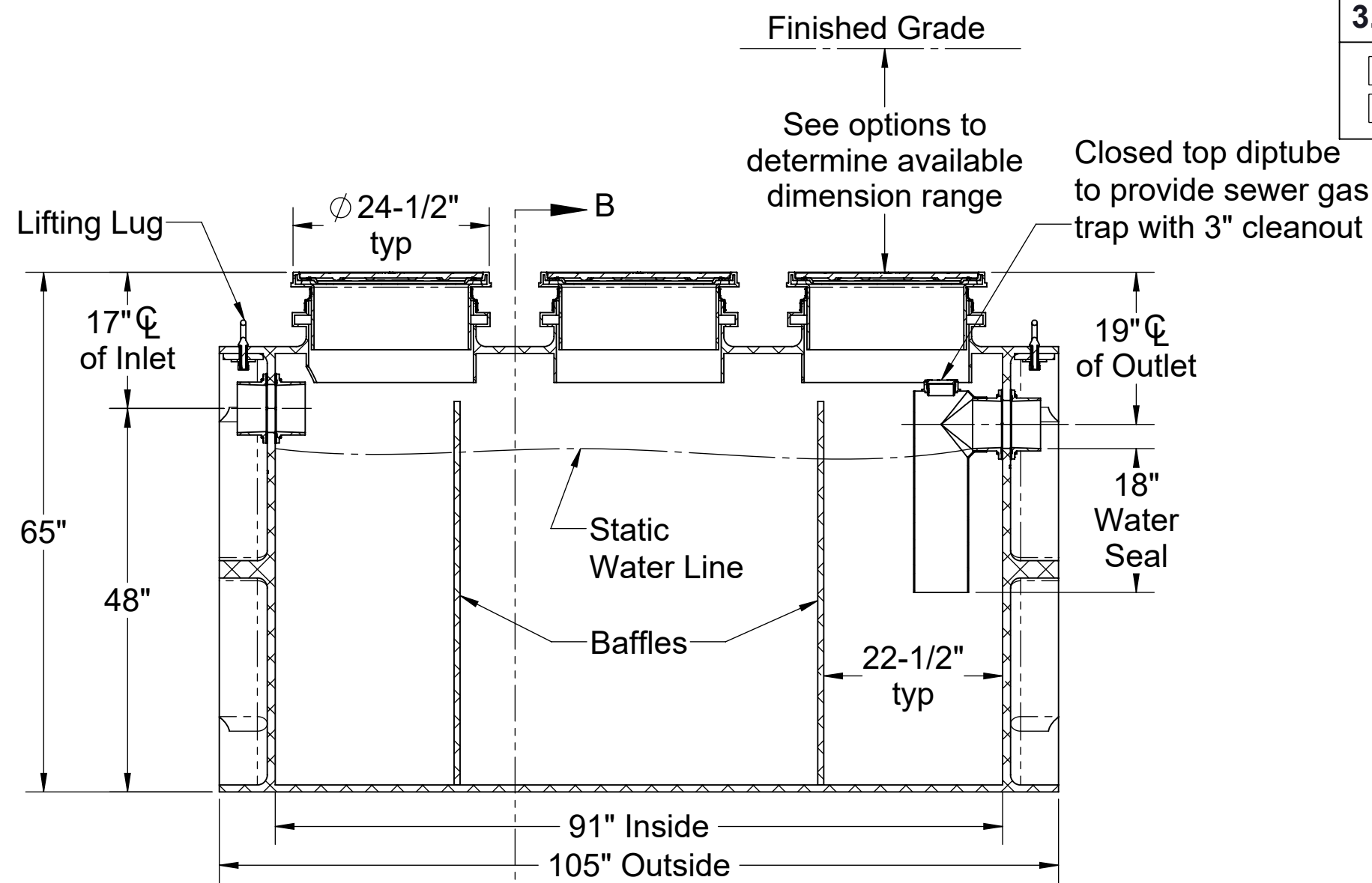

SECTION A-A

Directions: Complete steps 1-3 and submit signed with purchase order.

1. Choose Connection Types.

- | | |
|--------------------------------------|--|
| Inlet | Size |
| <input type="checkbox"/> Plain End | <input type="checkbox"/> 4" |
| <input type="checkbox"/> Male Thread | <input type="checkbox"/> 6" |
| | <input type="checkbox"/> 8" (Plain End Only) |

2. Riser Options.

- Included: 0" - 5"**
- SR24 (3): 5" - 24"
 - LR24 (3): 24" - 39"
 - SR24 (6): 39" - 43"
 - SR24 (3) + LR24 (3): 43" - 58"
 - LR24 (6): 58" - 72"
 - SR24 (3) + LR24 (6): 72" - 90"
 - LR24 (9): 90" - 106"
- OR -**
- CPRK (3): 11" - 106"
 - Corrugated Pipe Riser Kit.
 - Used in substitute of SR/LR riser options.
 - 18" diameter corrugated pipe by others.
 - See CPRK specification for more detail.

3. Choose Additional Options.

- HDK-4: High Water Table Hold Down Kit
- C24-HP: H2O Rated Pickable Cast Iron Covers

Signature of Approval: _____

Company: _____

Date of Approval: _____

Specifying Engineer: _____

Engineering Firm: _____

PO IS NON-CANCELABLE
ORDER IS NON-RETURNABLE

MODEL NUMBER: CB-750-S	
DESCRIPTION: SETTLER SERIES POLYETHYLENE CATCH BASIN 750 GALLON CAPACITY	
DWG BY: WLF	DATE: 1/27/22
REV: 0	ECO:

SPECIFICATION SHEET

Striem
3100 Brinkerhoff
Kansas City, KS 66115
Tel: 913-222-1500
orders@striemco.com
www.striemco.com



Made in the U.S.A

THE INFORMATION CONTAINED IN THIS DRAWING IS THE SOLE PROPERTY OF STRIEM, LLC. ANY REPRODUCTION IN PART OR AS A WHOLE WITHOUT THE WRITTEN PERMISSION OF STRIEM, LLC. IS PROHIBITED.