

SPECIFICATIONS

1. 6" Plain End inlet shown, 3" Plain End vents standard.
2. Liquid holding capacity: 2000 gallons (267 cu. ft.).
3. Unit weight: 1820 lbs.
4. Maximum operating temperature 140°F continuous.

NOTES

1. For gravity drainage applications only.
2. Do not use for pressure applications.
3. Cover placement allows full access to tank for proper maintenance.
4. Lifting lug set for easy install.

ENGINEER SPECIFICATION GUIDE

Striem decontamination tank model BB-2000 shall be lifetime guaranteed and made in the USA. Tank shall be constructed of polyethylene with 7/8" nominal wall thickness. Tank shall be manufactured for below-grade installation. Field-adjustable riser system is available as an option to bring manhole covers to grade. Tank liquid holding capacity shall be 2000 gallons. Covers shall provide water/gas-tight seal and have a maximum 16,000 lbs. load capacity.

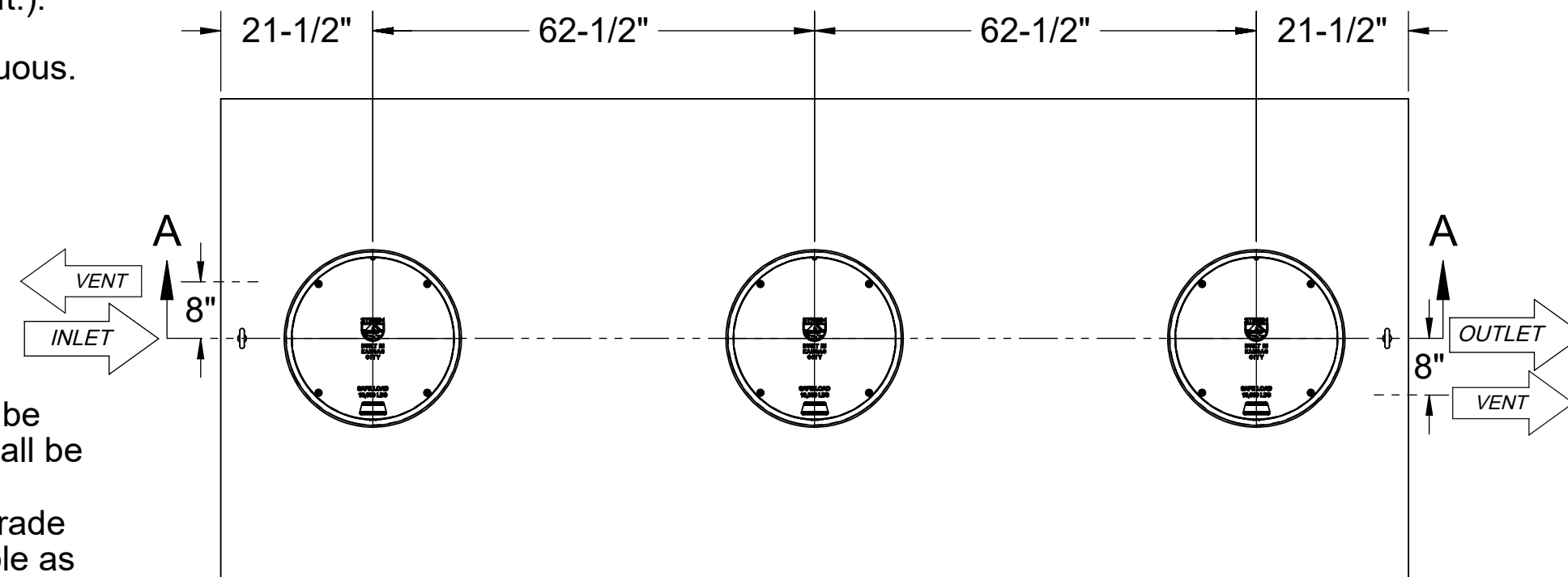

TOP VIEW

OPTIONS	
Connection Options (Plain End Only)	
Inlet	Optional Outlet
<input type="checkbox"/> 3"	<input type="checkbox"/> 3"
<input type="checkbox"/> 4"	<input type="checkbox"/> 4"
<input type="checkbox"/> 6"	<input type="checkbox"/> 6"
SELECTION REQUIRED	
Riser Options	
From Factory: 0" - 5"	
<input type="checkbox"/> Up to 24": SR24 (3)	
<input type="checkbox"/> Up to 39": LR24 (3)	
<input type="checkbox"/> Up to 43": SR24 (6)	
<input type="checkbox"/> Up to 58": SR24 (3) + LR24 (3)	
<input type="checkbox"/> Up to 72": LR24 (6)	
<input type="checkbox"/> Up to 90": SR24 (3) + LR24 (6)	
<input type="checkbox"/> Up to 106": LR24 (9)	
- OR -	
<input type="checkbox"/> CPRK (3): 11" - 106" (See specification for more detail.)	
Additional Options	
<input type="checkbox"/> HDK-7 : High Water Table Hold Down Kit	
<input type="checkbox"/> AVA-3 : Single-Level Monitoring Package *	
<input type="checkbox"/> AVA-4 : Multi-Level Monitoring Package *	
*Monitoring packages will raise covers by 3"	

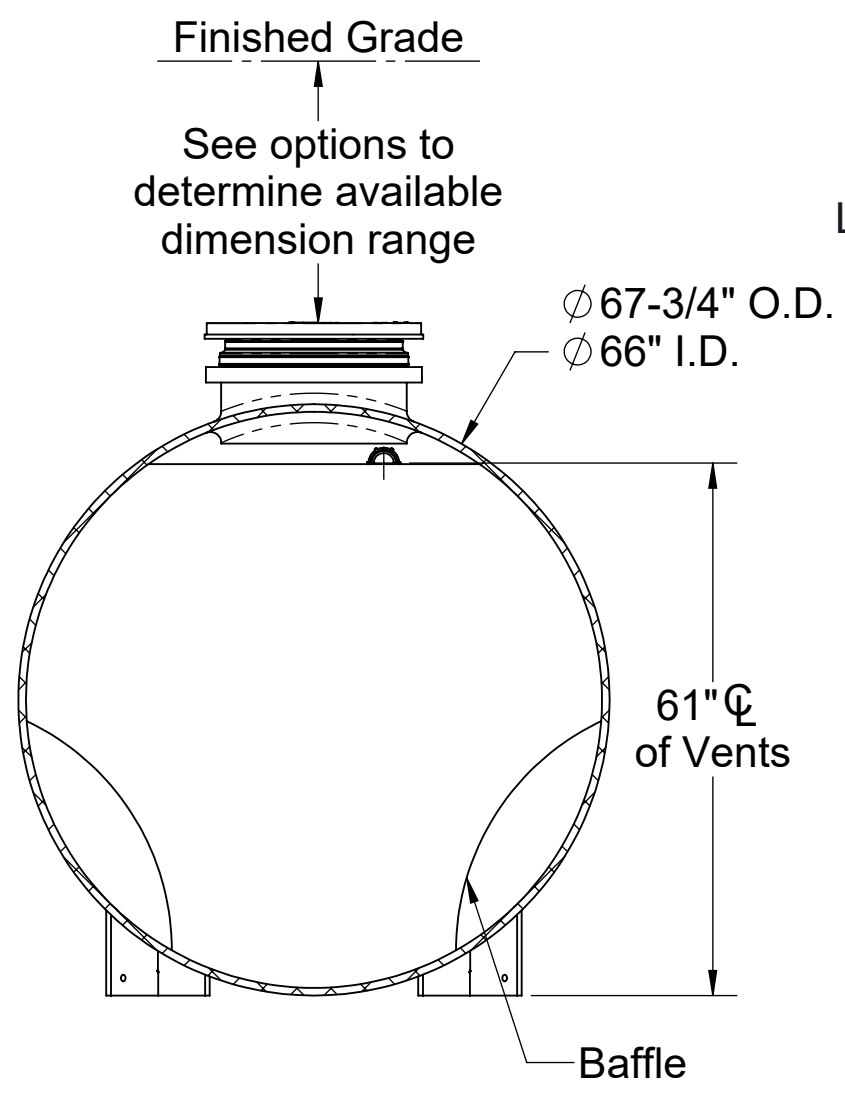

SECTION B-B

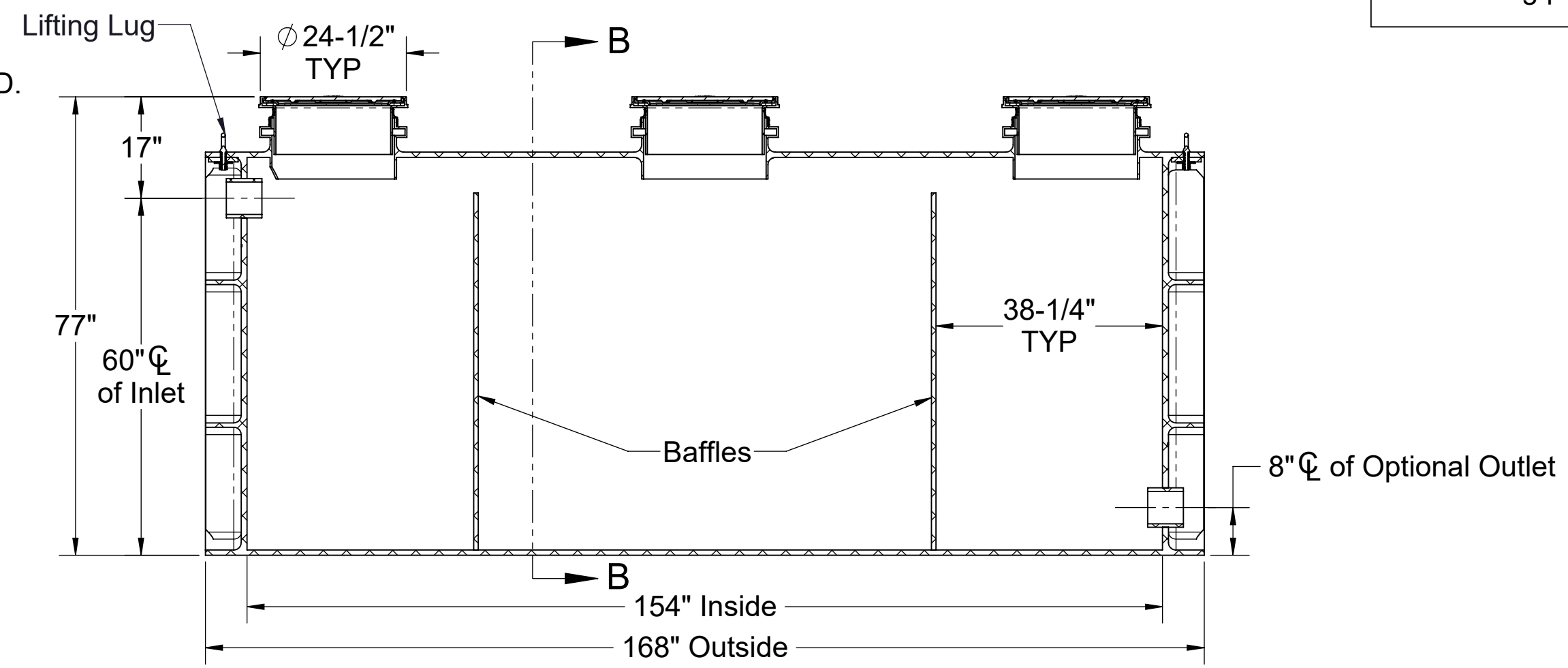

SECTION A-A

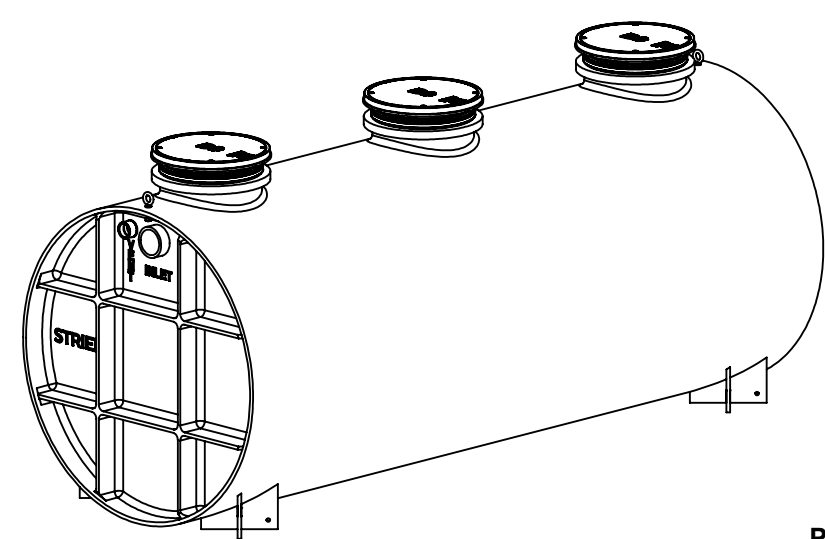

PO IS NON-CANCELABLE ORDER IS NON-RETURNABLE

MODEL NUMBER:	BB-2000
DESCRIPTION:	BIO BASIN™ POLYETHYLENE DECONTAMINATION TANK 2000 GALLON CAPACITY
DWG BY:	ENG
DATE:	8/22/2023
REV:	1

SPECIFICATION SHEET

Striem
Kansas City, KS
Tel: 913-222-1500
orders@striemco.com
www.striemco.com

Made in the U.S.A

PROPRIETARY AND CONFIDENTIAL
THE INFORMATION CONTAINED IN THIS DRAWING IS THE SOLE PROPERTY OF STRIEM, LLC.
ANY REPRODUCTION IN PART OR AS A WHOLE WITHOUT THE WRITTEN PERMISSION OF STRIEM, LLC. IS PROHIBITED.