

SPECIFICATIONS

1. 6" Plain End Inlet shown, 2" Plain End pump outlet, 3" Plain End vents standard.
2. Liquid holding capacity: 2000 gallons (267 cu. ft.).
3. Unit weight: 1820 lbs.
4. Maximum operating temperature 140°F continuous.

NOTES

1. For gravity drainage applications only.
2. Do not use for pressure applications.
3. Cover placement allows full access to tank for proper maintenance.
4. Lifting lug set for easy install.

ENGINEER SPECIFICATION GUIDE

Striem decontamination tank model BB-2000-PP shall be lifetime guaranteed and made in the USA. Tank shall be constructed of polyethylene with 7/8" nominal wall thickness. Tank shall be manufactured for below-grade installation. Field-adjustable riser system is available as an option to bring manhole covers to grade. Tank liquid holding capacity shall be 2000 gallons. Covers shall provide water/gas-tight seal and have a maximum 16,000 lbs. load capacity.

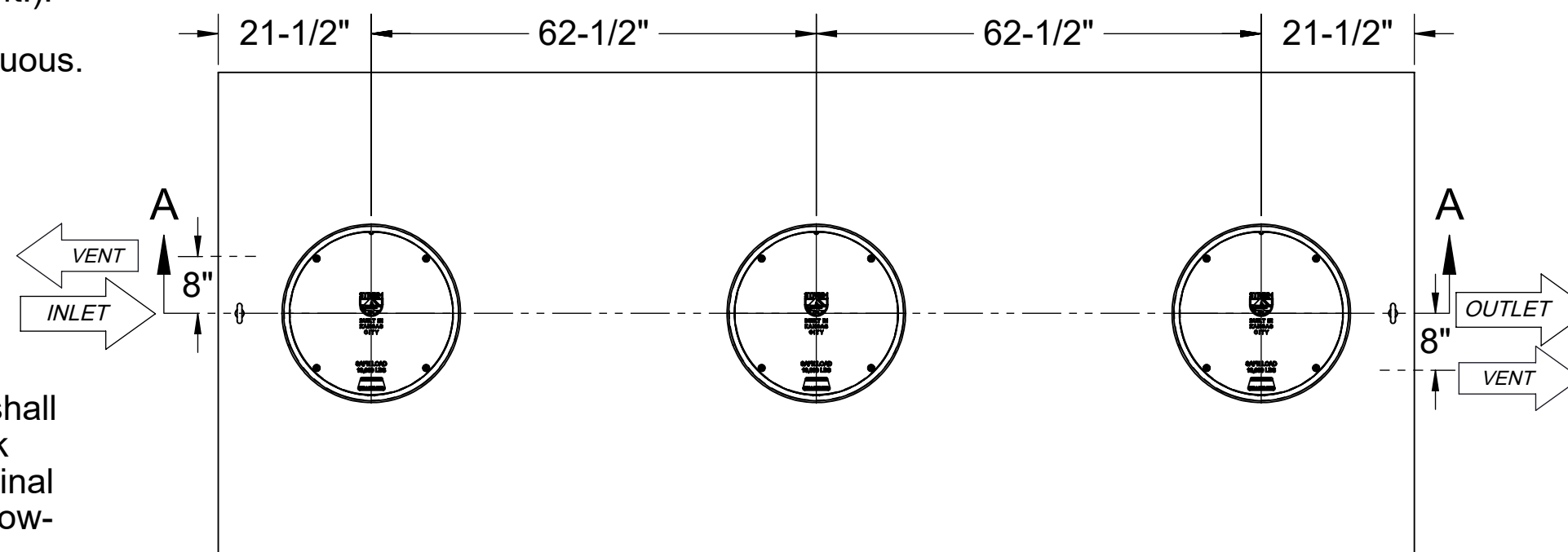

TOP VIEW

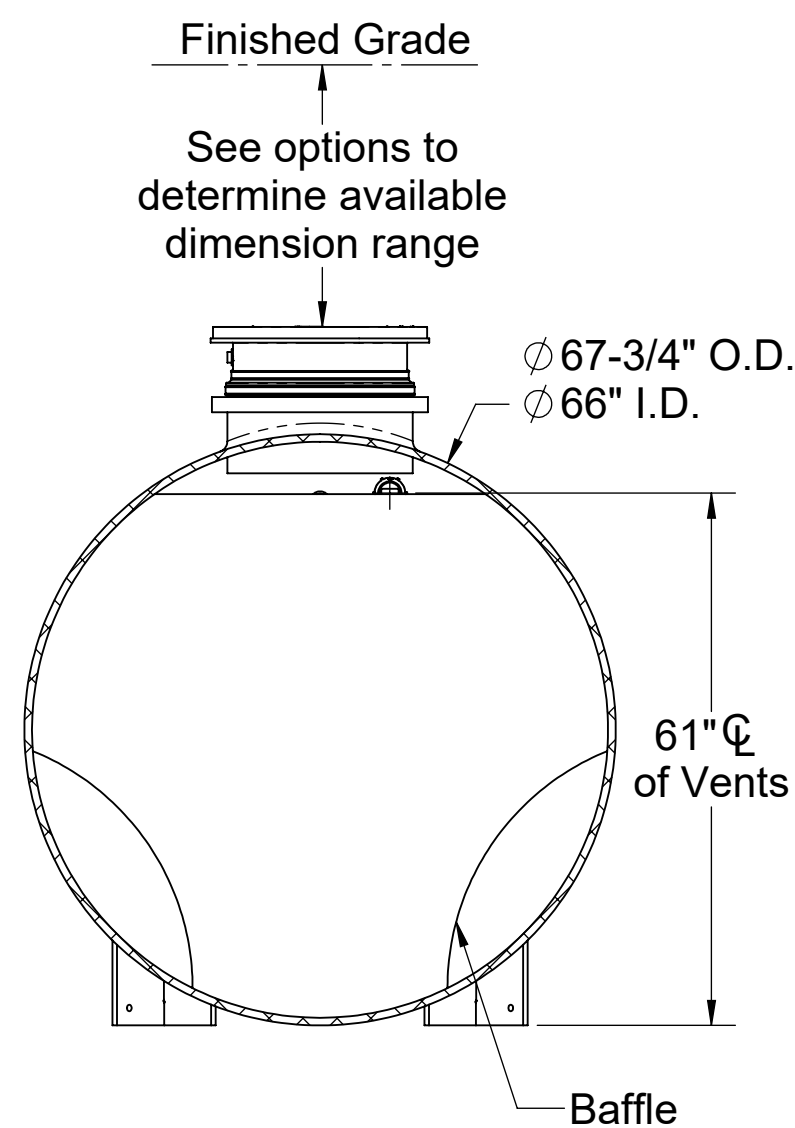

SECTION B-B

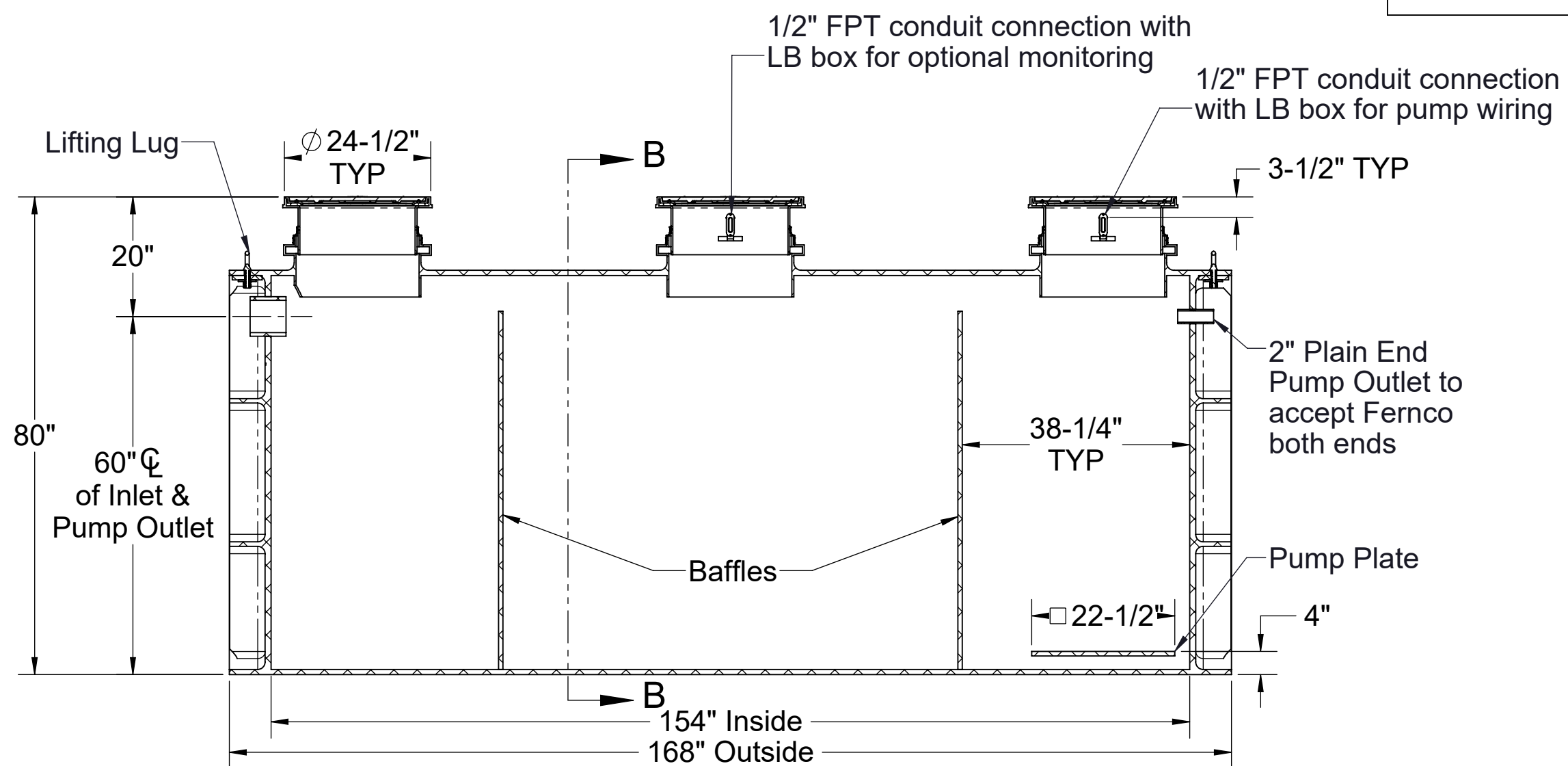

SECTION A-A

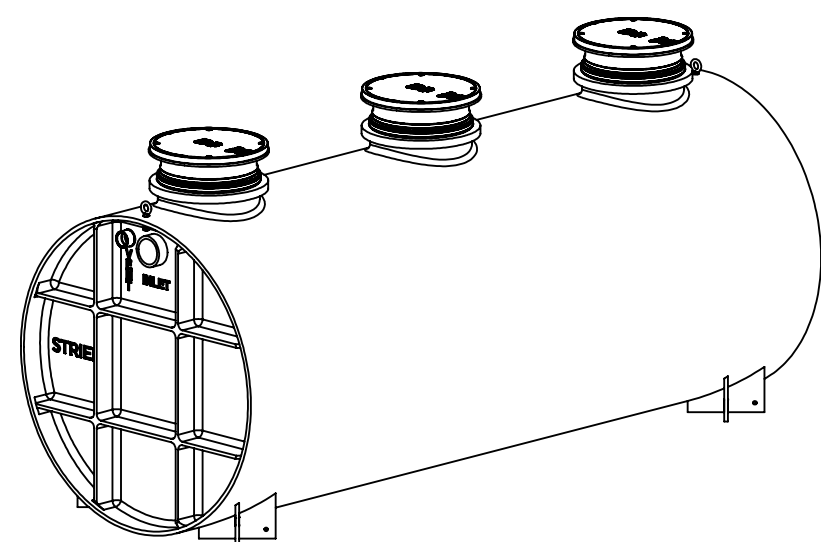

**PO IS NON-CANCELABLE
ORDER IS NON-RETURNABLE**

PROPRIETARY AND CONFIDENTIAL
THE INFORMATION CONTAINED IN THIS DRAWING IS THE SOLE PROPERTY OF STRIEM, LLC.
ANY REPRODUCTION IN PART OR AS A WHOLE WITHOUT THE WRITTEN PERMISSION OF STRIEM, LLC. IS PROHIBITED.

OPTIONS

Connection Options (Plain End Only)

Inlet

- 3"
- 4"
- 6"

**SELECTION
REQUIRED**

Riser Options

From Factory: Up to 2"

- Up to 21": **SR24** (3)
- Up to 36": **LR24** (3)
- Up to 40": **SR24** (6)
- Up to 55": **SR24** (3) + **LR24** (3)
- Up to 69": **LR24** (6)
- Up to 87": **SR24** (3) + **LR24** (6)
- Up to 103": **LR24** (9)

- OR -

- CPRK** (3): 11" - 103" (See specification for more detail.)

Additional Options

- HDK-7**: High Water Table Hold Down Kit
- AVA-3**: Single-Level Monitoring Package
- AVA-4**: Multi-Level Monitoring Package

MODEL NUMBER: BB-2000-PP

DESCRIPTION:
BIO BASIN™
POLYETHYLENE DECONTAMINATION TANK
WITH PUMP PLATE
2000 GALLON CAPACITY

DWG BY: ENG **DATE:** 7/25/2023 **REV:** 2

SPECIFICATION SHEET

Striem
Kansas City, KS
Tel: 913-222-1500
orders@striemco.com
www.striemco.com

Made in the U.S.A

