

SPECIFICATIONS

1. Liquid capacity: 500 gallons (66 cu. ft.).
2. Solids capacity: 400 gallons.
3. Unit weight: 900 lbs.
4. Maximum operating temperature 140°F continuous.
5. H2O rated cast iron grate.

NOTES

1. For gravity drainage applications only. Do not use for pressure applications.
2. Cover placement allows full access to tank for proper maintenance.
3. Lifting lug set for easy install.
4. For below-grade installation only.

ENGINEER SPECIFICATION GUIDE

Striem Settler™ catch basin model CB-500-G shall be lifetime guaranteed and made in USA of High Density Polyethylene with a 7/8" nominal wall thickness. Tank shall be furnished for below-grade installation with field adjustable riser system. Solids capacity shall be 400 gallons.

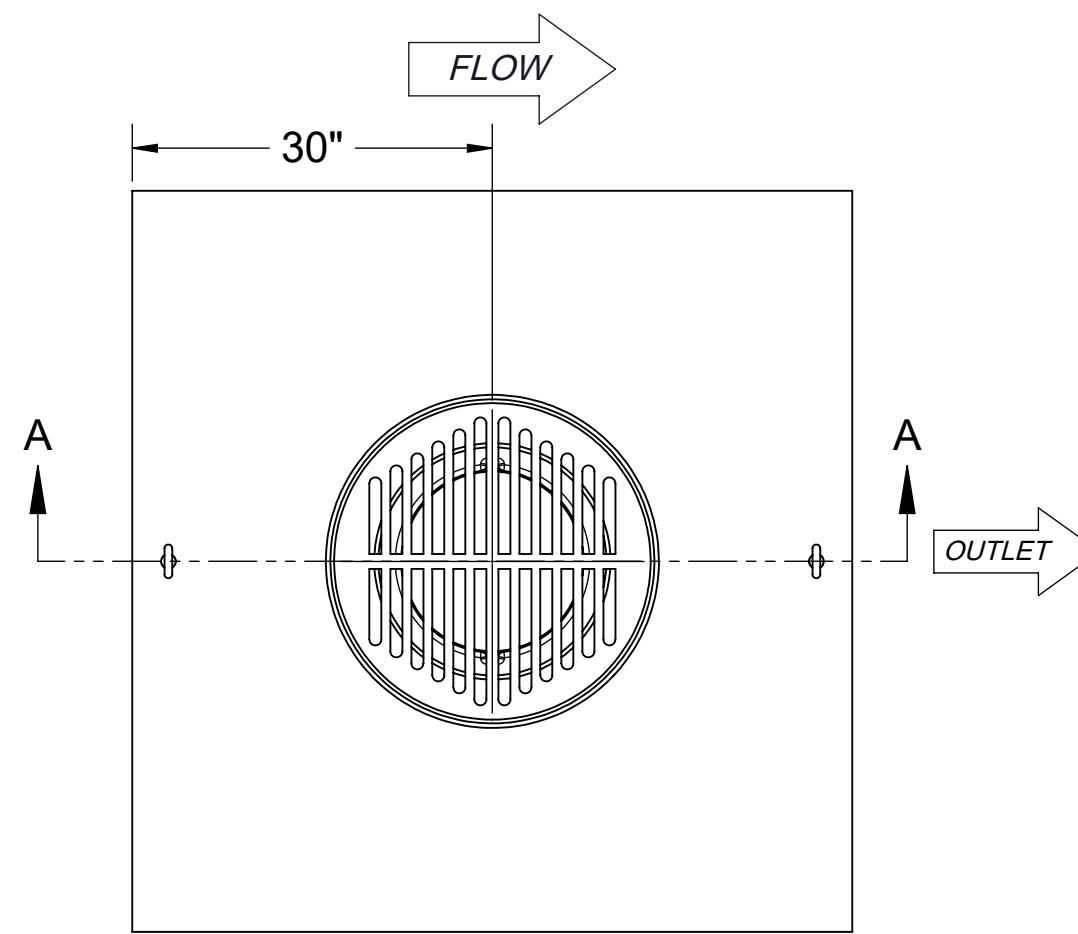

TOP VIEW

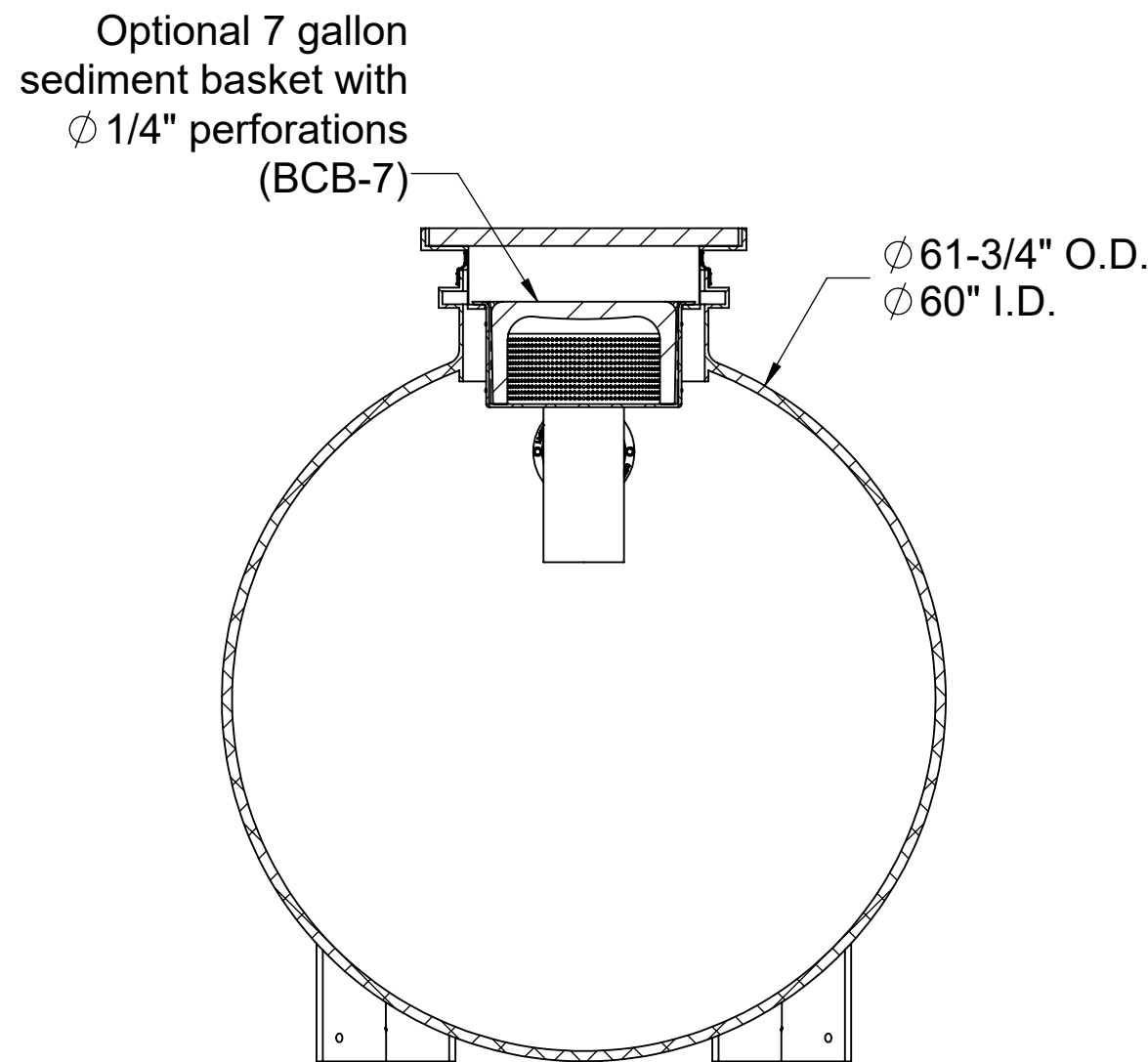

SECTION B-B

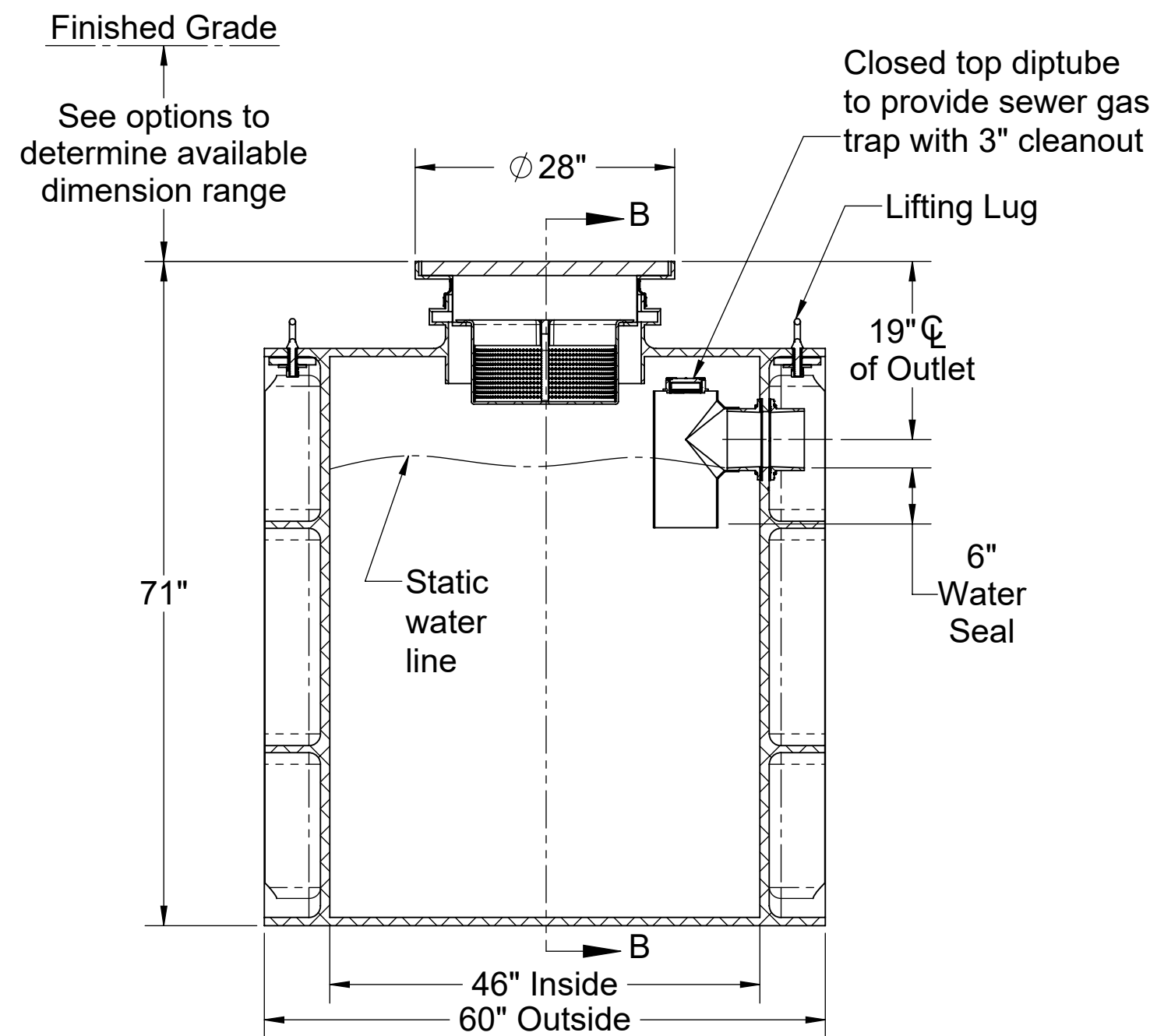

SECTION A-A

Directions: Complete steps 1-3 and submit signed with purchase order.

1. Choose Connection Types.

Outlet	Size
<input type="checkbox"/> Plain End	<input type="checkbox"/> 4"
<input type="checkbox"/> Male Thread	<input type="checkbox"/> 6"

2. Riser Options.

- Included:** 0" - 2-1/2"
- SR24:** 5" - 24"
 - LR24:** 24" - 39"
 - SR24 (2):** 39" - 43"
 - SR24 + LR24:** 43" - 58"
 - LR24 (2):** 58" - 72"
 - SR24 + LR24 (2):** 72" - 90"
 - LR24 (3):** 90" - 106"
- *If in the range of 2-1/2" - 5", contact Striem for a custom solution.

3. Choose Additional Options.

- HDK-8:** High Water Table Hold Down Kit
- BCB-7:** 7 gallon sediment basket with ϕ 1/4" perforations

Signature of Approval: _____
 Company: _____
 Date of Approval: _____
 Specifying Engineer: _____
 Engineering Firm: _____

PO IS NON-CANCELABLE
 ORDER IS NON-RETURNABLE

MODEL NUMBER:	CB-500-G
DESCRIPTION:	SETTLER SERIES POLYETHYLENE CATCH BASIN WITH HIGHWAY RATED CAST IRON GRATE 500 GALLON CAPACITY
DWG BY: WLF	DATE: 8/22/22
REV: 0	ECO:

SPECIFICATION SHEET

Striem
 3100 Brinkerhoff
 Kansas City, KS 66115
 Tel: 913-222-1500
 orders@striemco.com
 www.striemco.com

Made in the U.S.A



PROPRIETARY AND CONFIDENTIAL
 THE INFORMATION CONTAINED IN THIS DRAWING IS THE SOLE PROPERTY OF STRIEM, LLC.
 ANY REPRODUCTION IN PART OR AS A WHOLE WITHOUT THE WRITTEN PERMISSION OF STRIEM, LLC. IS PROHIBITED.