

**SPECIFICATIONS**

1. 2" Plain inlet/No outlet, 3" Plain vents.
2. Oil capacity: 250 Gallons (33.4 cu ft).
3. Unit weight w/std. covers: 220 lbs.
4. Maximum operating temperature: 140°F continuous.
5. Highway rated covers: 16,000 lb. capacity.

**NOTES**

1. Seamless polyethylene tank.
2. Unit supplied with built-in adapter(s) for up to 5" of adjustability. Additional riser(s) available for deeper burial depth.
3. Cover placement allows full access to tank for proper maintenance.
4. Narrow footprint allows clearance through doorways and down stairwells.
5. For on-the-floor or buried applications.

**ENGINEER SPECIFICATION GUIDE**

Striem Oil Reserve™ oil collection tank model OCT-275 shall be lifetime guaranteed and made in USA of seamless, rotationally-molded Polyethylene with minimum 3/8" uniform wall thickness. Separator shall be furnished for above or below grade installation, with field adjustable riser system, 2" Plain inlet line and 3" Plain vent connections. Oil collection tank shall have an oil storage capacity of 250 gallons. Cover shall provide water/gas-tight seal and have maximum 16,000 lbs load capacity.

**THIRD PARTY STRUCTURAL ANALYSIS**

The OCT-275 has been structurally analyzed in accordance with the requirements of IBC 2012 and ASCE/SEI 7 for direct burial. The maximum burial depth and backfill material are specified in our installation instructions. The structural design has been reviewed and sealed by a professional engineer registered in the state of California. A sealed structural analysis report is available upon request.

**OPTIONS**

- 3P:** 3" Plain End Inlet
- 3M:** 3" Male Thread Inlet
- 4M:** 4" Male Thread Inlet
- 6P:** 6" Plain End Inlet
- 6M:** 6" Male Thread Inlet
- C24-HP (2):** H2O Rated Pickable Cast Iron Cover
- CC24 (2):** Integral Membrane Clamping Collar Kit
- HDK-2:** High Water Anchor Kit
- AVA-3:** Single Level Monitoring Package\*
- AVA-4:** Multi-Level Monitoring Package\*

\*Monitoring packages will raise covers by 3".

**RISER OPTIONS**

- Included:** 0"-5" (0"-2" w/ monitoring)
- SR24 (2):** 5"-24" (2"-21" w/ monitoring)
  - LR24 (2):** 24"-39" (21"-36" w/ monitoring)
  - SR24 (4):** 39"-43" (36"-40" w/ monitoring)
  - SR24 (2) + LR24 (2):** 43"-58" (40"-55" w/ monitoring)
  - LR24 (4):** 58"-72" (55"-69" w/ monitoring)
  - SR24 (2) + LR24 (4):** 72"-90" (69"-87" w/ monitoring)

**-OR-**

- CPRK (2):** 11" - 90" (11"-87" w/ monitoring)
  - Corrugated Pipe Riser Kit.
  - 18" diameter corrugated pipe by others.
  - Used in substitute of SR/LR riser options
  - See CPRK specification for more detail.

PROPRIETARY AND CONFIDENTIAL

THE INFORMATION CONTAINED IN THIS DRAWING IS THE SOLE PROPERTY OF STRIEM, LLC. ANY REPRODUCTION IN PART OR AS A WHOLE WITHOUT THE WRITTEN PERMISSION OF STRIEM, LLC. IS PROHIBITED.

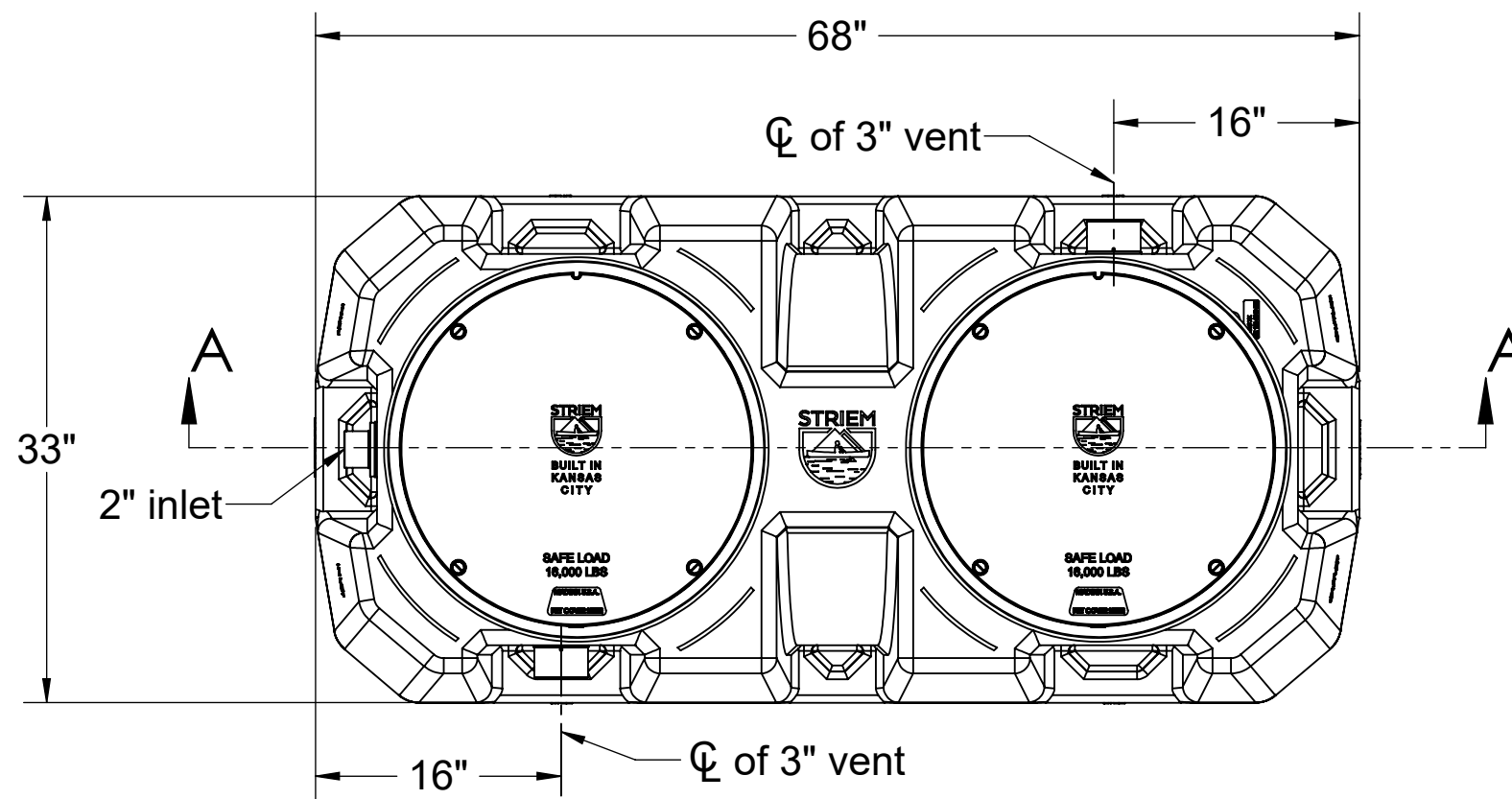

**TOP VIEW**

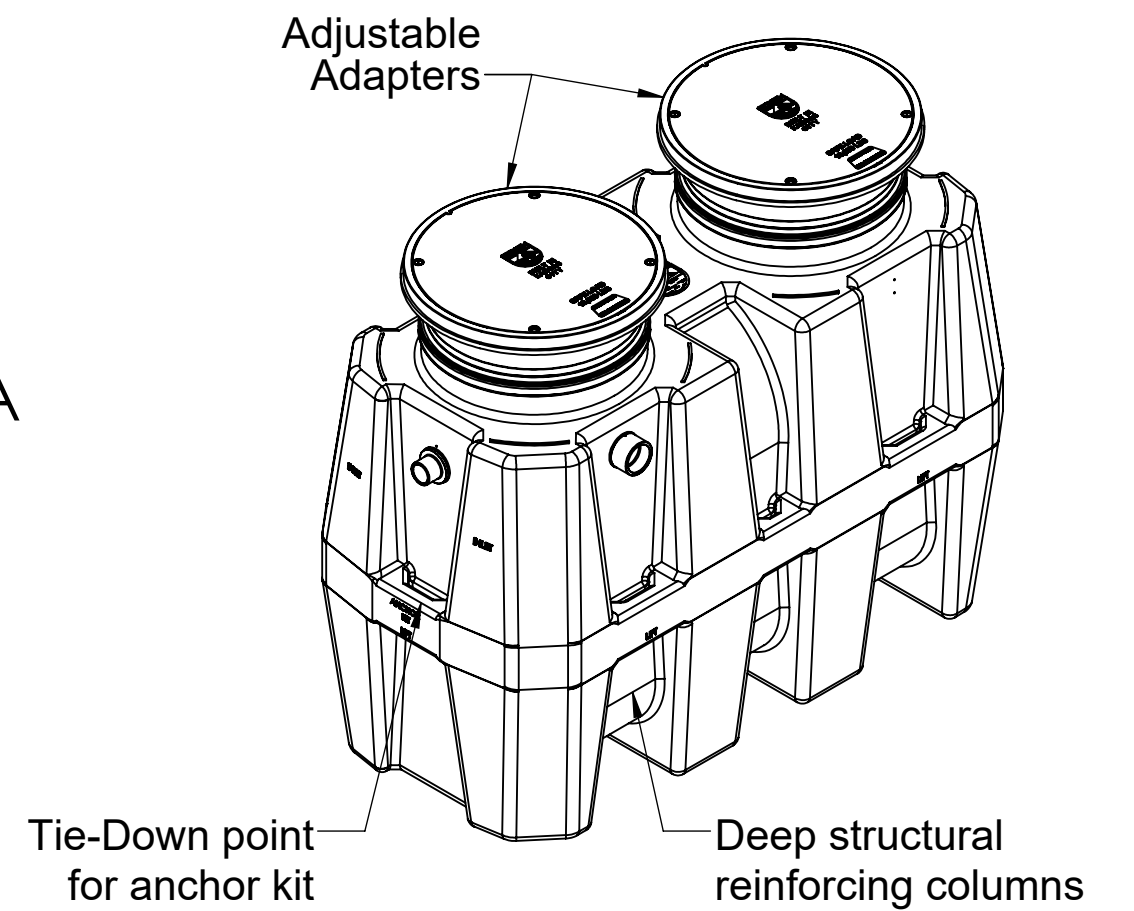

**ISOMETRIC VIEW**

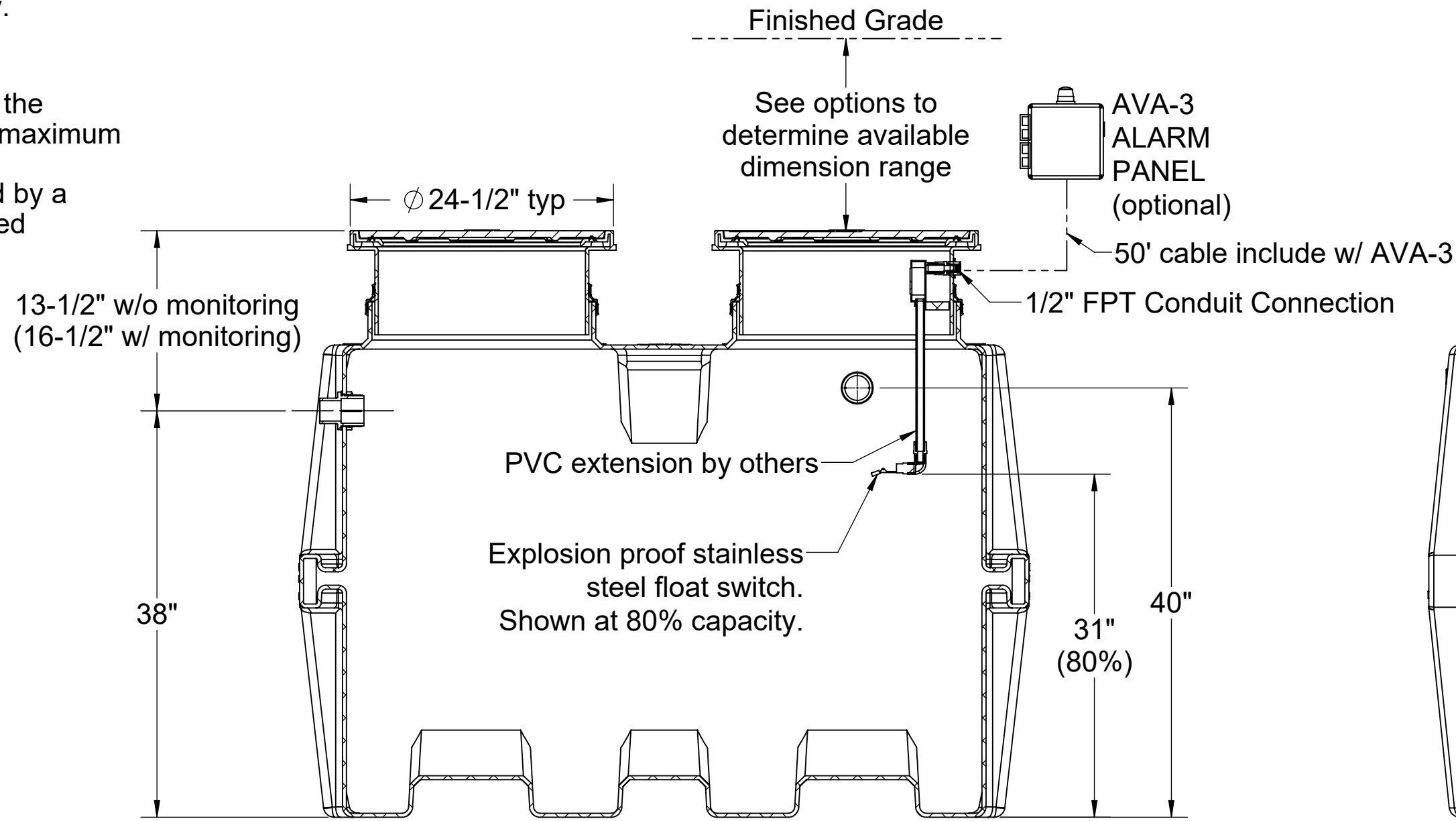

**SECTION A-A**

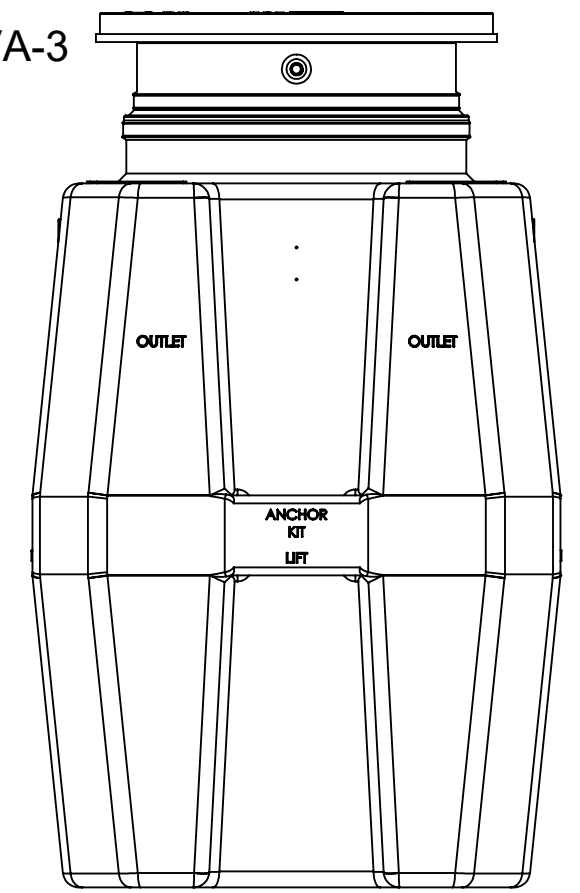

**END VIEW**

<b>MODEL NUMBER:</b> OCT-275	
<b>DESCRIPTION:</b> 250 GAL POLYETHYLENE OIL COLLECTION TANK	
<b>DWG BY:</b> WLF	<b>DATE:</b> 6/23/22
<b>REV:</b> 0	<b>ECO:</b>

**SPECIFICATION SHEET**

**Striem**  
3100 Brinkerhoff  
Kansas City, KS 66115  
Tel: 913-222-1500  
orders@striemco.com  
www.striemco.com

Made in the U.S.A

