



# FWT-35

## FLAMMABLE WASTE TRAP

### Installation, Operation, & Maintenance Guide

# FWT-35

## FLAMMABLE WASTE TRAP

### Installation, Operation, & Maintenance Guide

#### OVERVIEW

Striem Flammable Waste Trap model FWT-35 is a polyethylene flammable waste trap intended for above or below-grade installation. It is designed to separate insoluble flammable liquids and solids from wastewater.

#### OPERATION

Contaminated wastewater enters through the inlet connection. As wastewater moves through the unit, solids and immiscible lighter-than-water flammable liquids are separated based on Stokes' Law. The immiscible, lighter-than water, flammable liquid droplets rise out of the wastewater stream, while sediment and sludge settle to the bottom.

#### LIFETIME WARRANTY

Contaminated wastewater enters through the inlet connection. As wastewater moves through the unit, solids and immiscible lighter-than-water flammable liquids are separated based on Stokes' Law. The immiscible lighter-than water flammable liquid droplets rise out of the wastewater stream, while sediment and sludge settle to the bottom.

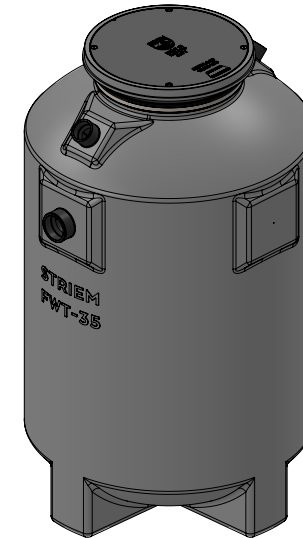

**FWT-35**  
35 CUBIC FEET  
262 GALLONS  
FLAMMABLE WASTE TRAP

913-222-1500    [HELP@STRIEMCO.COM](mailto:HELP@STRIEMCO.COM)    [STRIEMCO.COM](http://STRIEMCO.COM)  
CUSTOMER SERVICE HOURS: 8 AM - 5 PM CST



# WARNING



## DO NOT AIR PRESSURE TEST UNIT!

DOING SO MAY RESULT IN PROPERTY DAMAGE,  
SERIOUS BODILY INJURY, OR DEATH!

Refer to Installation Instructions for correct testing procedure.

### LEAK/SEAL TESTING

**Do not air test unit or Teleglide Riser system!** Doing so may result in property damage, personal injury or death.

To perform a leak/seal test on the base unit, cap/plug all plumbing connections, remove the cover, and fill the unit with water just above the highest connection. Inspect unit and connections for leaks. Check water level at specific time intervals per local code.

### MAINTENANCE

- 1 Always take proper care to ensure a safe and healthy environment while maintaining the flammable waste trap. Avoid the presence of sparks or open flames while maintaining the unit.
- 2 Remove cover.
- 3 Contact a professional pumper contractor to remove all contents of the flammable waste trap, including flammable liquids, sediment, and wastewater.
- 4 Clean the drain lines and diffusers thoroughly of all debris.
- 5 Fill FWT-35 with water to outlet invert.
- 6 Inspect cover gasket for wear and tear and reinsert cover.
- 7 Dispose of contents per local code.

### PUMPING FREQUENCY

FWT-35 must be maintained prior to reaching maximum flammable liquid or sediment capacity for the unit to continue working efficiently.

Pumping frequency depends on the amount of flammable liquids and sediment in the wastewater. Monitor flammable liquid and sediment levels to determine site specific maintenance schedule requirements.

Flammable liquid levels can be tested with a core sampler. Striem recommends a minimum pumping frequency of 6 months.

### TROUBLESHOOTING TIPS



Slower than usual drainage may indicate a blockage and a need to maintain the flammable waste trap.

Ensure the drain lines and diffuser are cleared of all debris in the presence of slow drainage.

Effluent flow fouled with free flammable liquids may indicate the FWT-35 has exceeded the maximum flammable liquid capacity. In the presence of flammable liquids in the effluent flow, maintain the unit immediately.

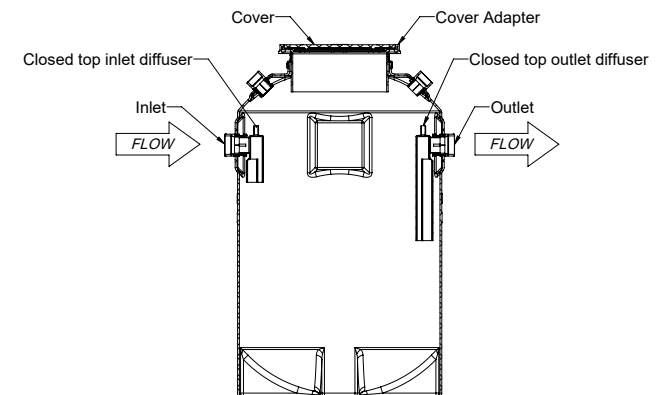

## ABOVE GRADE INSTALLATION INSTRUCTIONS

### UNIT INSTALLATION

- 1 Connect waste piping to unit.
- 2 Fill FWT-35 with water to outlet invert.
- 3 Ensure cover is properly installed.
- 4 FWT-35 is ready for use.

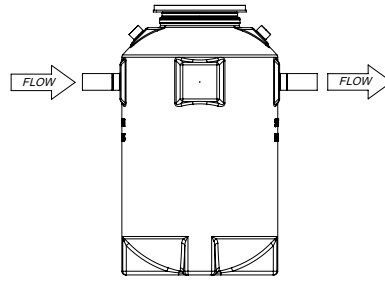

## BELOW GRADE INSTALLATION INSTRUCTIONS

### EXCAVATION

- 1 FWT-35 has a minimum burial depth of 12".
- 2 Surrounding soil must be undisturbed soil or well compacted engineering fill.
- 3 Width and length of excavation shall be minimum 12" greater than the tank on all sides.
- 4 Depth of excavation shall be 6" deeper than tank bottom.
- 5 Anchor kit is recommended for installations in high water table conditions to prevent float out. To be determined by specifying engineer. If necessary, order optional "High Water Anchor Kit (HDK-10)".

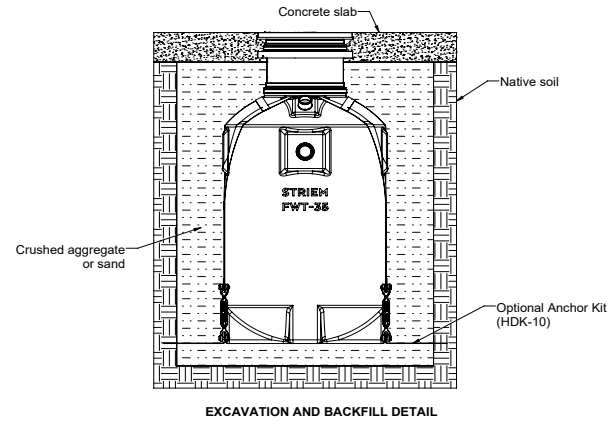

EXCAVATION AND BACKFILL DETAIL

### UNIT INSTALLATION

- 1 Lower and center the unit into the excavated hole. Do not use chains or accessways to move the unit.
- 2 The water table must not exceed the tank height prior to the addition of risers.
- 3 Ensure the unit cover is level with finished grade.
- 4 Fill FWT-35 with water before backfilling to stabilize the unit and prevent float out during backfilling.

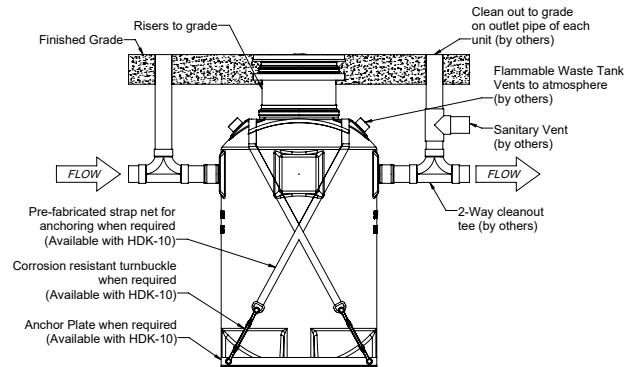

### BACKFILLING & FINISHED CONCRETE SLAB

- 1 Preparation of sub grade per geotech recommendations.
- 2 Stabilize and compact sub grade to 95% proctor.
- 3 Before backfilling and pouring of slab, secure covers and risers (if used) to the unit.
- 4 Place 6" aggregate base under slab. Aggregate should be 3/4" size rock, or sand, with no fines.
- 5 Backfill using crushed aggregate material approximately 3/4" size rock, or sand, with no fines.
- 6 Thickness of concrete around cover to be determined by specifying engineer. If traffic loading is required the concrete slab dimensions shown are for guideline purposes only.
- 7 Concrete to be 28 day compressive strength to 4000 PSI with  $6 \pm 1\%$  air entrainment.
- 8 NO. 4 rebar (1/2") grade 60 steel per ASTM A615: connected with tie wire.
- 9 Rebar to be 2 1/2" from edge of concrete.
- 10 Rebar spacing 12" grid. 4" spacing around access openings.

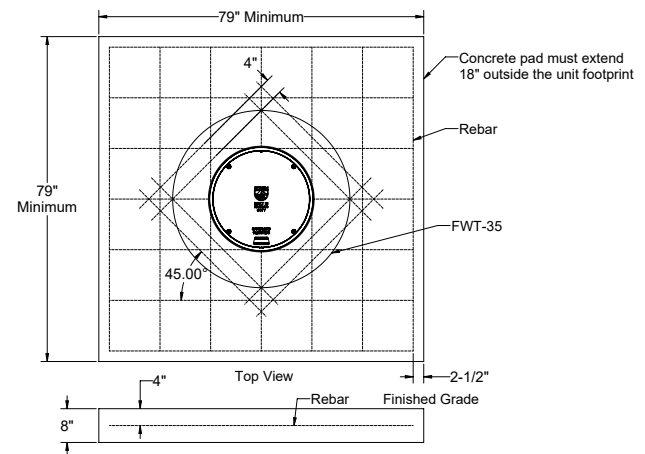

## TELEGLIDE RISER | INSTALLATION INSTRUCTIONS

CORRUGATED PIPE RISER KIT (CPRK) AVAILABLE AS ALTERNATE RISER SOLUTION. SEE CPRK INSTALLATION INSTRUCTIONS FOR MORE DETAILS.

- 1
  - Place FWT-35 so that the pipe connections line up with jobsite piping.
  - Measure dimension X to determine riser height needed.
  - Select the required risers from the adjacent table. Riser chart shows quantity for each tank manway.

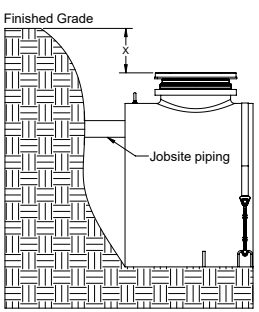

Standard Cover Adapter	
Riser Height Needed	Risers Required Per Manway
12" - 24"	SR24 (1)
24" - 39"	LR24 (1)
39" - 43"	SR24 (2)
43" - 58"	SR24 (1), LR24 (1)
58" - 72"	LR24 (2)
72" - 90"	SR24 (1) + LR24 (2)
Cover Adapter with Slick Stick™	
9" - 21"	SR24 (1)
21" - 36"	LR24 (1)
36" - 40"	SR24 (2)
40" - 55"	SR24 (1), LR24 (1)
55" - 69"	LR24 (2)
69" - 87"	SR24 (1) + LR24 (2)

- 2
  - Loosen upper clamp with **nut driver bit (included with tank)**.
  - If no risers are needed, adjust cover adapter height as needed.
  - Ensure 2-1/2" minimum engagement is maintained.
  - If risers are needed, remove cover from cover adapter, and cover adapter from the unit.

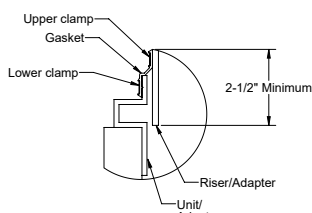

- 3
  - Insert cover adapters into the required risers until they stop.
  - Tighten upper clamp to keep risers from shifting. Risers are installed from short to long.
  - If using a standard cover adapter, measure the riser height needed,  $X + 5.25"$  down the sidewall of the risers.
  - If using a cover adapter with Slick Stick™, measure the riser height needed,  $X + 7.75"$  down the sidewall of the risers.
  - Mark the location with **china marker (included with tank)**.
  - Cover adapter may need to be adjusted outward for some dimension ranges. If mark is at the end of riser, no cutting is required.

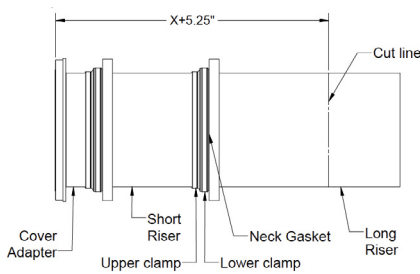

- 4
  - Uninstall cover adapter and risers
  - Extend mark made in **step 3** around the circumference of the riser.
  - Cut along line with jigsaw, circular saw, or reciprocating saw.
  - Make a mark around the circumference of the riser 3" from the cut end of riser.
  - If no cuts were needed, make the mark 3" from the bottom of the bottom riser.

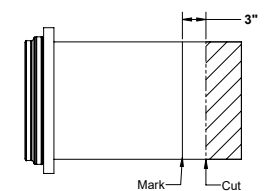

- 5
  - Wipe clean all riser and cover adapter sidewalls.
  - Insert the first riser into the tank neck until the mark made in **step 4** is in-line with the top of the neck gasket. This will ensure your risers reach the finished grade measured in **step 1**.

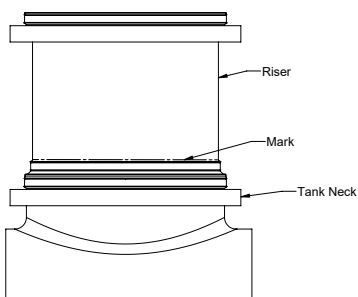

- 6
  - Install risers and cover adapter into the tank neck starting from the marked riser, moving up to finished grade.
  - Upper clamps may need to be loosened or removed to aid in assembly.

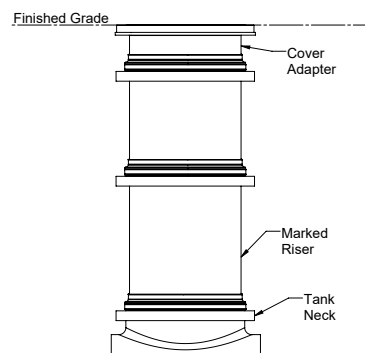

- 7
  - Tighten all clamps to 14 lbs. of torque.
  - Reinstall cover on cover adapter.
  - If tilting of the cover adapter is required to be flush with finished floor, it must be done after all clamps are tightened. A 6.5° tilt is the maximum.

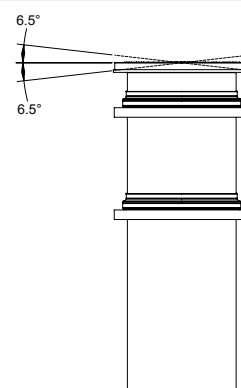

- 8
  - If jobsite riser height conditions change after the previous steps have been completed, there is still room for vertical adjustment.
  - As long as the minimum engagement of 2-1/2" on all joints are maintained, the adapters and risers may be adjusted/cut as many times as necessary.

