

**SPECIFICATIONS**

1. 4" Plain End outlet shown.
2. Liquid Capacity: *See unit options.*
3. Cover weight limit: 450 lbs.
4. Maximum operating temperature 165°F intermittent.

**NOTES**

1. All inlet connections are field installed.

**ENGINEER SPECIFICATION GUIDE**

Striem Tuff Trough shall be lifetime guaranteed and made in the USA of 3/4" polyethylene. Trough shall be certified to IAPMO/ANSI/CAN Z1167 and carry a UPC listing. Trough shall have removable, corrosion-resistant primary filter screen and secondary filter basket. Trough shall be furnished with a nested cover, internally sloped floor, and suitable for above- or below-grade installation. Trough shall be equipped with a plain end outlet. Inlet connections are field installed. Cover shall have a maximum 450 lbs. load capacity. Maximum operating temperature 165°F intermittent.

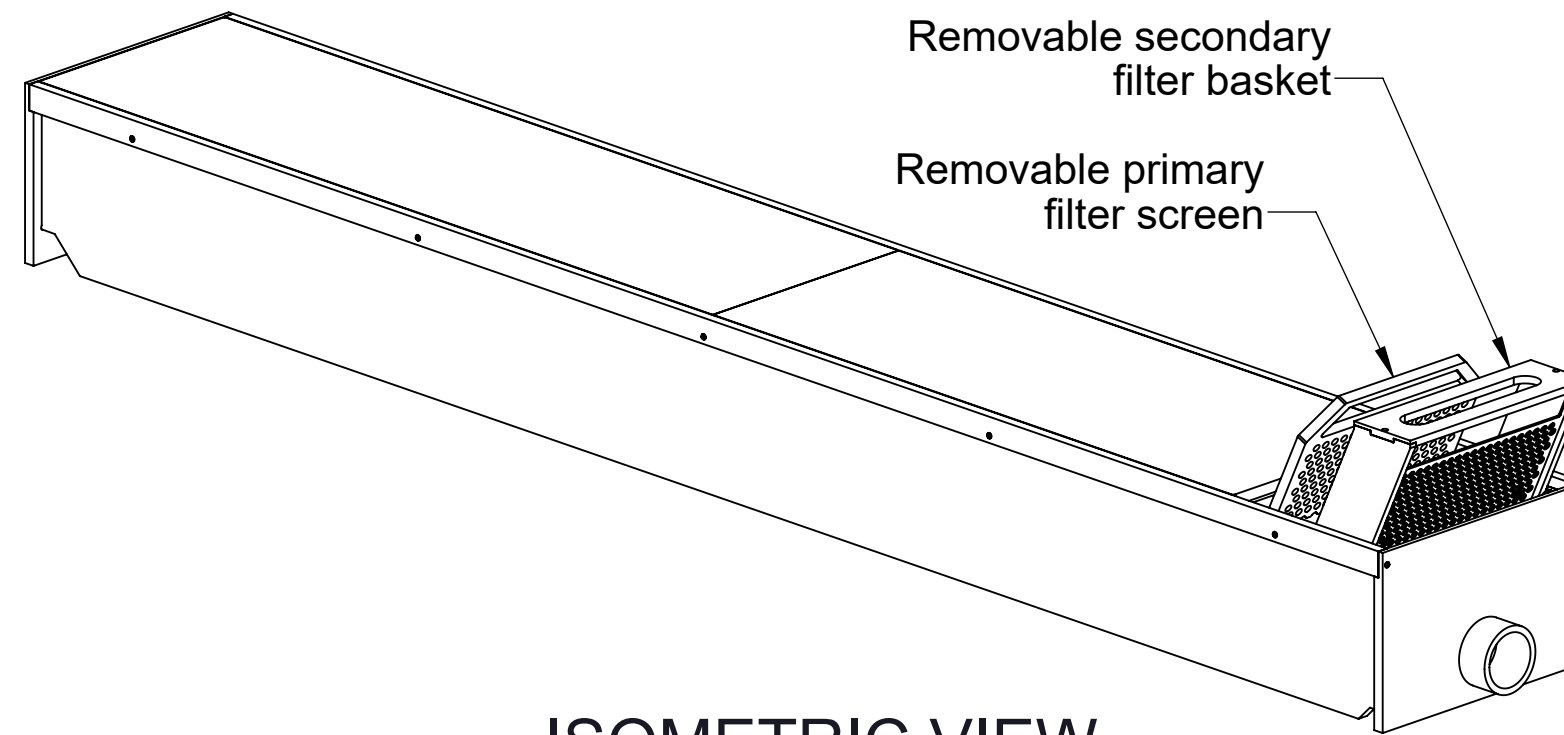

**ISOMETRIC VIEW**

**OPTIONS**

**Select Unit**

- TT-3:** 3' x 18" x 12" 21 gal.
- TT-4:** 4' x 18" x 12" 28 gal.
- TT-5:** 5' x 18" x 12" 34 gal.
- TT-6:** 6' x 18" x 12" 41 gal.
- TT-8:** 8' x 18" x 12" 55 gal.
- TT-10:** 10' x 18" x 12" 68 gal.

**Additional Options**

- IBK-3:** 3" Plain End Inlet Bulkhead Kit Qty: \_\_\_\_\_

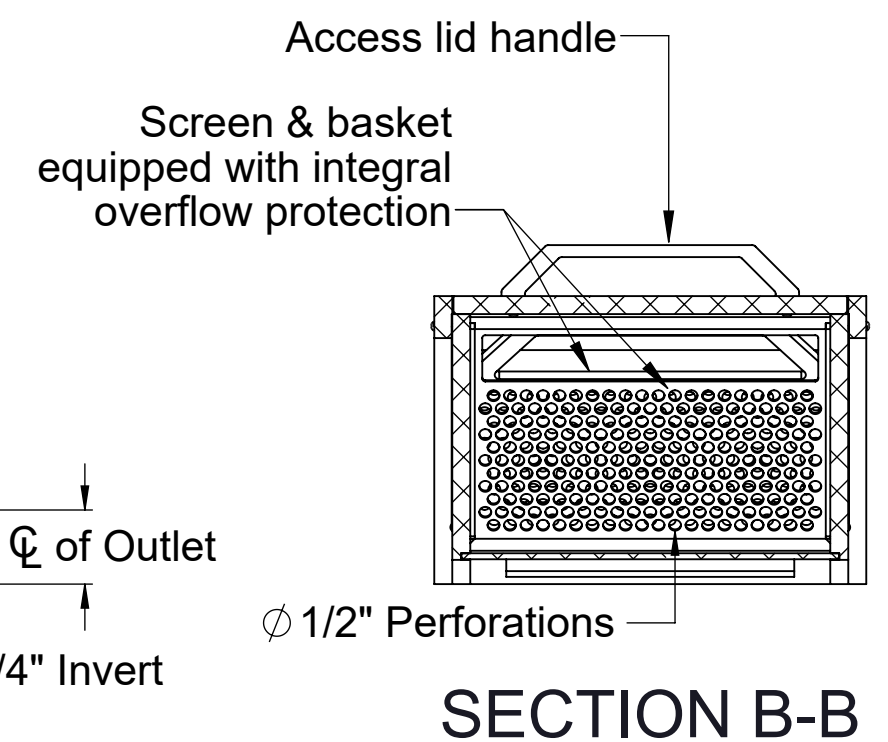
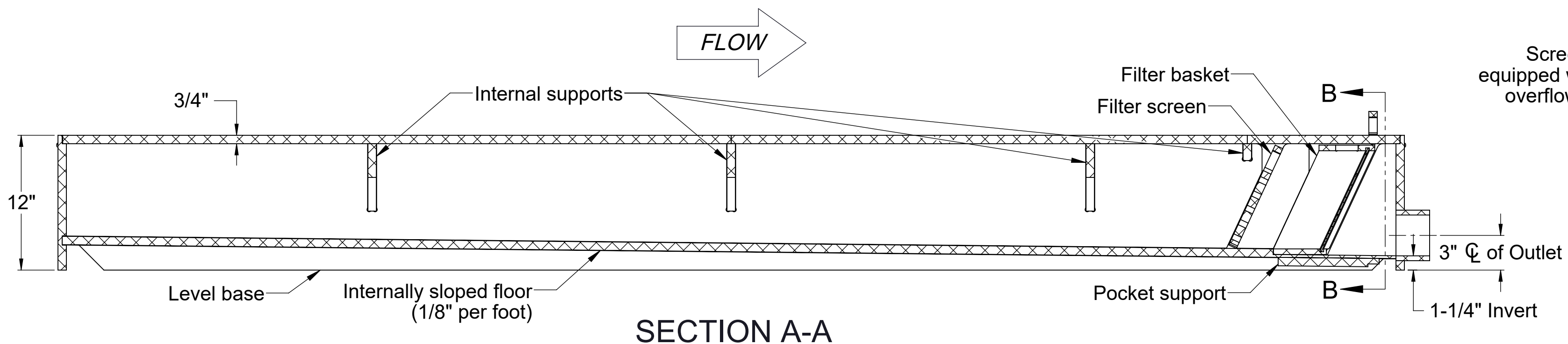
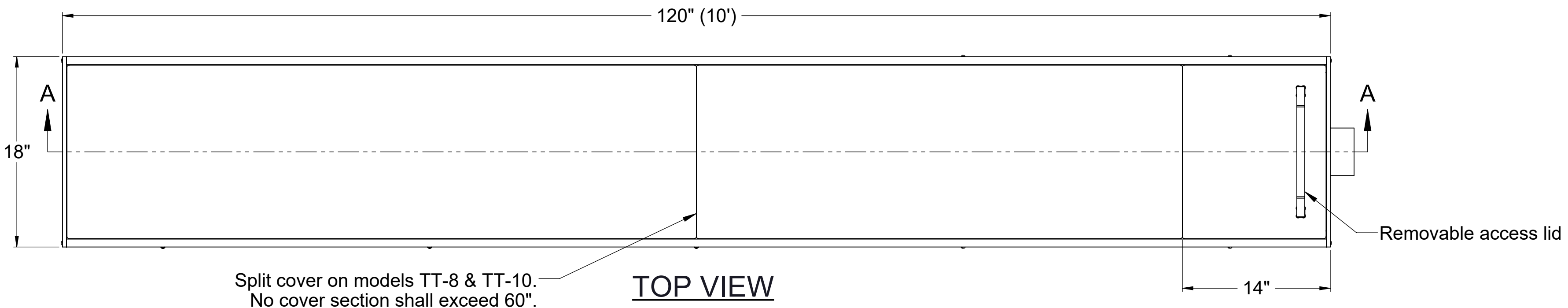

PO IS NON-CANCELABLE  
ORDER IS NON-RETURNABLE

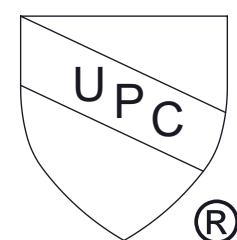

**DESCRIPTION:**

TUFF TROUGH  
POLYETHYLENE DRAIN TROUGH  
(TT-10 shown)

**SPECIFICATION SHEET**

**Striem**  
Kansas City, KS  
Tel: 913-222-1500  
orders@striemco.com  
www.striemco.com

Made in the U.S.A



PROPRIETARY AND CONFIDENTIAL  
THE INFORMATION CONTAINED IN THIS DRAWING IS THE SOLE PROPERTY OF STRIEM, LLC.  
ANY REPRODUCTION IN PART OR AS A WHOLE WITHOUT THE WRITTEN PERMISSION OF STRIEM, LLC. IS PROHIBITED.

**DWG BY:** ENG    **DATE:** 8/20/2024    **REV:** 2