

SPECIFICATIONS

- 3" Plain end vents standard.
- Liquid capacity: 262 Gallons (35 cu. ft.).
- Solids capacity: 163 Gallons (26.2 cu. ft.).
- Flammable waste capacity: 89 Gallons (14.2 cu. ft.).
- Unit weight w/std. cover: 175 lbs.
- Highway rated covers: 16,000 lb. capacity.
- Maximum operating temperature 140°F continuous.
- For above- or below-grade applications.
- Minimum burial depth: 9".
- Slick Stick™ Oil Level Monitoring System.

ENGINEER SPECIFICATION GUIDE

Striem model FWT-35-SS shall be lifetime guaranteed and made in USA of seamless, rotationally-molded polyethylene. Interceptor shall be furnished for above- or below-grade installation, with field adjustable riser system, and (2) vent connections. Interceptor capacity shall be 89 gallons of flammable waste, and 163 gallons of sediment. Cover shall provide water/gas-tight seal and have a maximum 16,000 lbs load capacity.

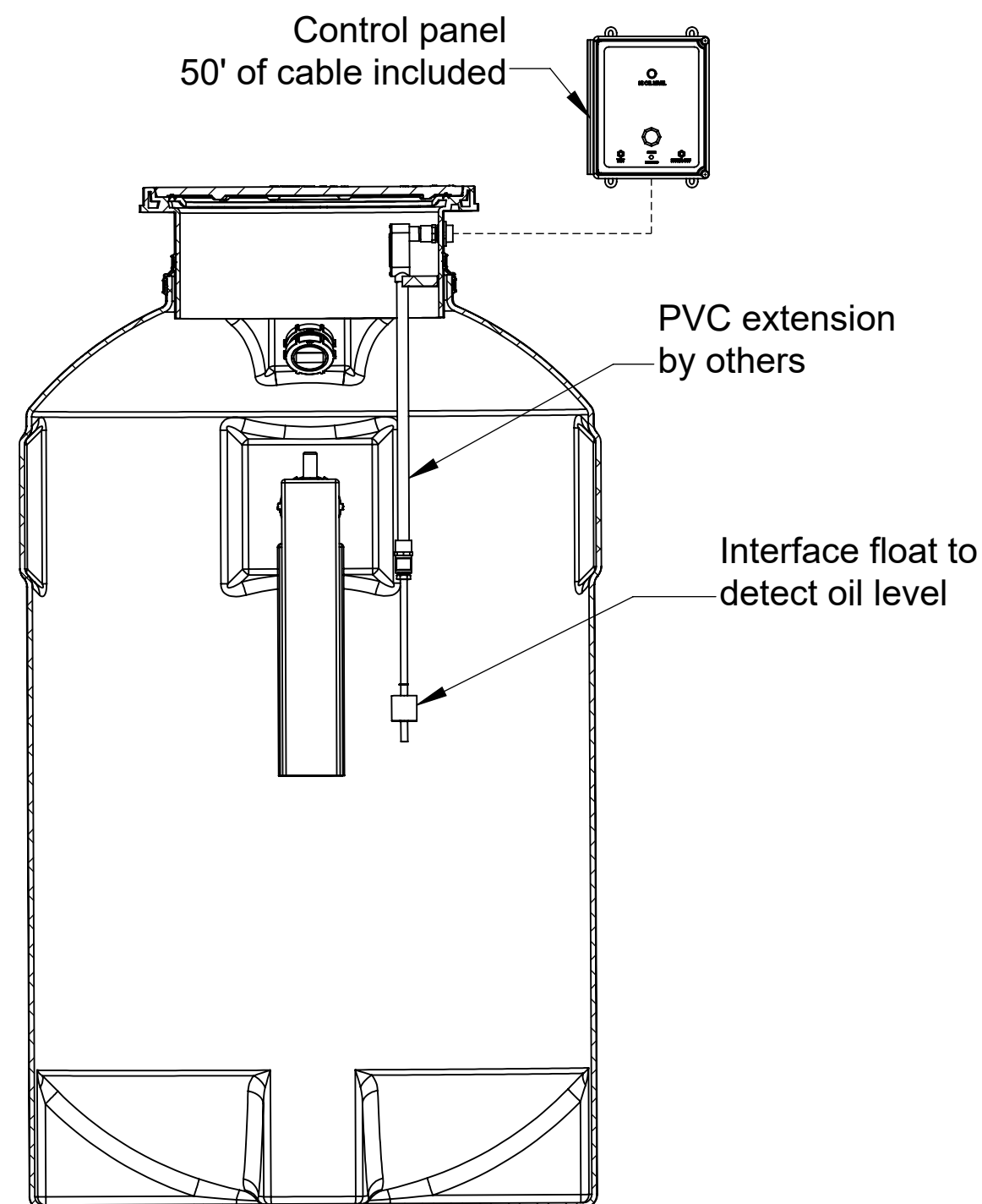

SECTION B-B

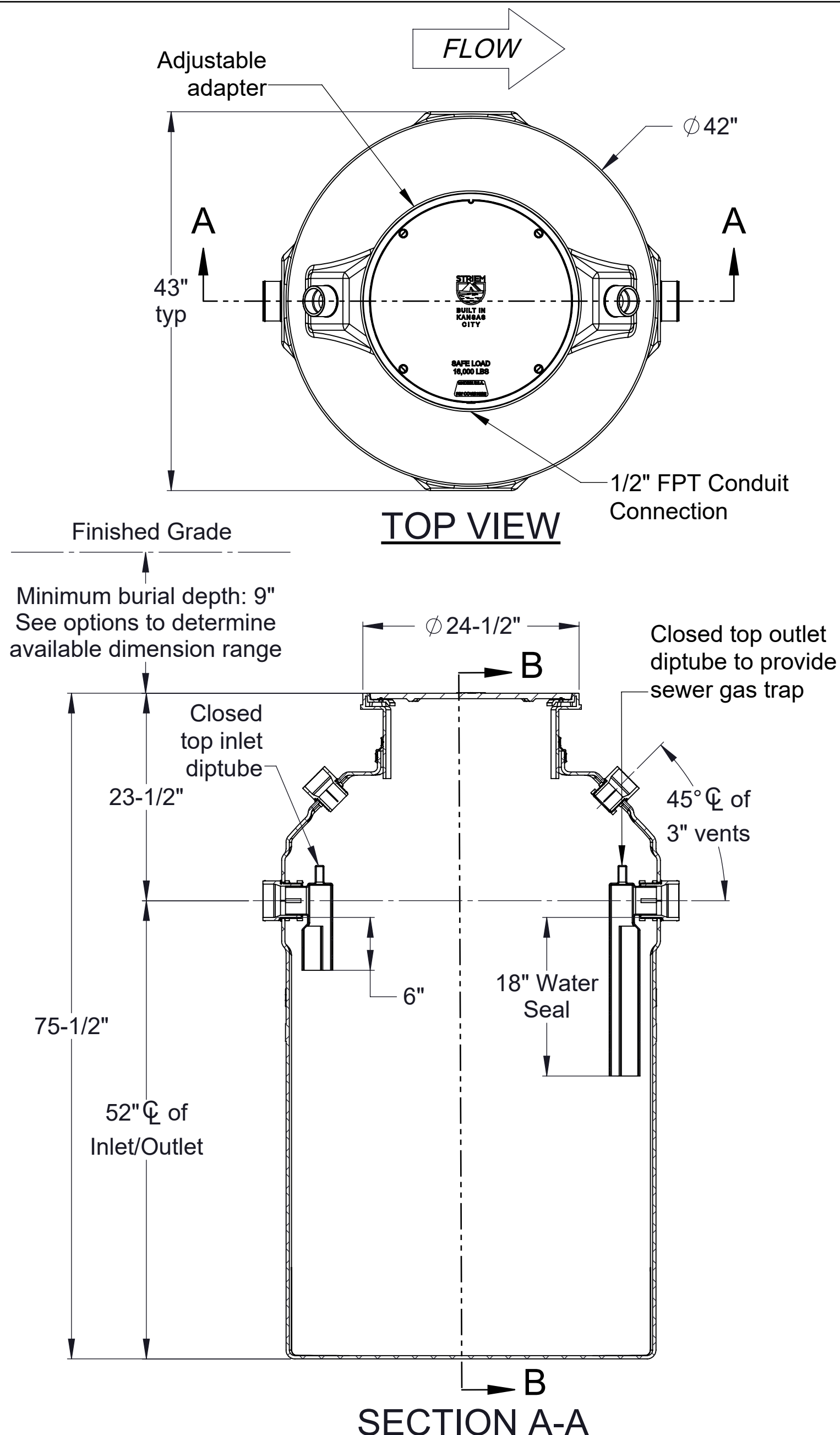

SECTION A-A

OPTIONS

Connection Types

Inlet/Outlet	Size
<input type="checkbox"/> Plain End	<input type="checkbox"/> 4"
<input type="checkbox"/> Male Thread	<input type="checkbox"/> 6"

Riser Options

- SR24: 9" - 21"
- LR24: 21" - 36"
- SR24 (2): 36" - 40"
- SR24 + LR24: 40" - 55"
- LR24 (2): 55" - 69"
- SR24 + LR24 (2): 69" - 87"
- OR -
- CPRK: 11" - 87"
 - Corrugated Pipe Riser Kit.
 - 18" diameter corrugated pipe by others.
 - See CPRK specification for more detail.

Additional Options

- C24-HP: H2O Rated Pickable Cast Iron Cover
- HDK-10: High Water Table Hold Down Kit

MODEL NUMBER: FWT-35-SS

DESCRIPTION:
**FLAMMABLE WASTE TRAP
 35 CUBIC FOOT
 UNRATED**

DWG BY: ENG DATE: 1/11/2023 REV: 0

SPECIFICATION SHEET

Striem
 3100 Brinkerhoff
 Kansas City, KS 66115
 Tel: 913-222-1500
 orders@striemco.com
 www.striemco.com

Made in the U.S.A

