

SPECIFICATIONS

1. 4" Plain End inlet/outlet, 3" Plain End vents, C24-H cover standard.
2. Liquid capacity: 262 Gallons (35 cu. ft.).
3. Solids capacity: 145 Gallons (19.4 cu. ft.).
4. Flammable waste capacity: 105 Gallons (14 cu. ft.).
5. Unit weight w/ standard cover: 175 lbs.; w/ cast iron cover: 235 lbs.
6. Maximum operating temperature 140°F continuous.
7. Minimum burial depth: 9".
8. Slick Stick Oil Level Monitoring System.

ENGINEER SPECIFICATION GUIDE

Striem flammable waste trap model FWT-35-SS shall be lifetime guaranteed and made in the USA. FWT-35-SS shall be constructed of polyethylene. FWT-35-SS shall be manufactured for above- or below-grade installation. Field-adjustable riser system is available as an option to bring manhole cover to grade. FWT-35-SS liquid holding capacity shall be 262 gallons and flammable waste capacity shall be 105 gallons. Solids capacity shall be 145 gallons. Cover shall provide water/gas-tight seal and have a maximum 16,000 lbs. load capacity.

OPTIONS	
Connection Options (Plain End Only)	
Inlet / Outlet	
<input type="checkbox"/> 4"	
<input type="checkbox"/> 6"	
Riser Options	
Minimum Burial Depth: 9"	
<input type="checkbox"/> Up to 21": SR24	
<input type="checkbox"/> Up to 36": LR24	
<input type="checkbox"/> Up to 40": SR24 (2)	
<input type="checkbox"/> Up to 55": SR24 + LR24	
<input type="checkbox"/> Up to 69": LR24 (2)	
<input type="checkbox"/> Up to 87": SR24 + LR24 (2)	
- OR -	
<input type="checkbox"/> CPRK: 11" - 87" (See specification for more detail.)	
Additional Options	
<input type="checkbox"/> C24-HP: H20 Rated Pickable Cast Iron Cover	
<input type="checkbox"/> HDK-10: High Water Table Hold Down Kit	

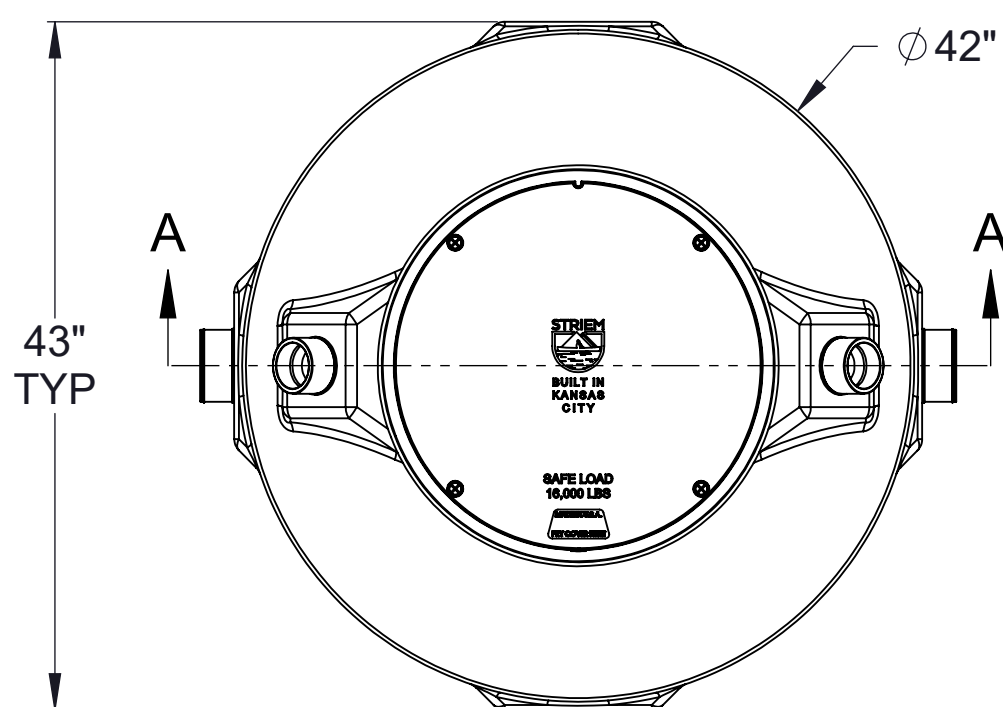

TOP VIEW

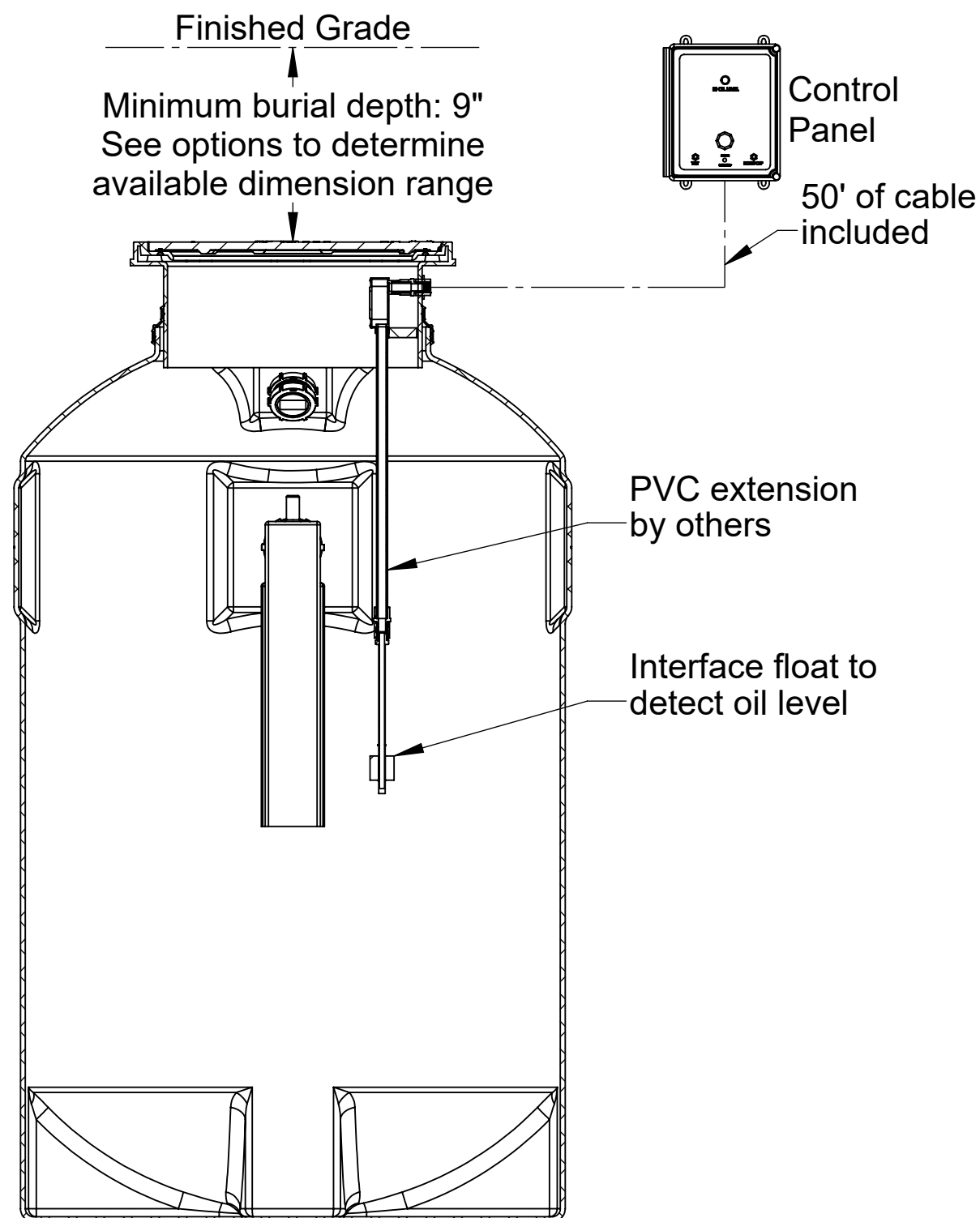

SECTION B-B

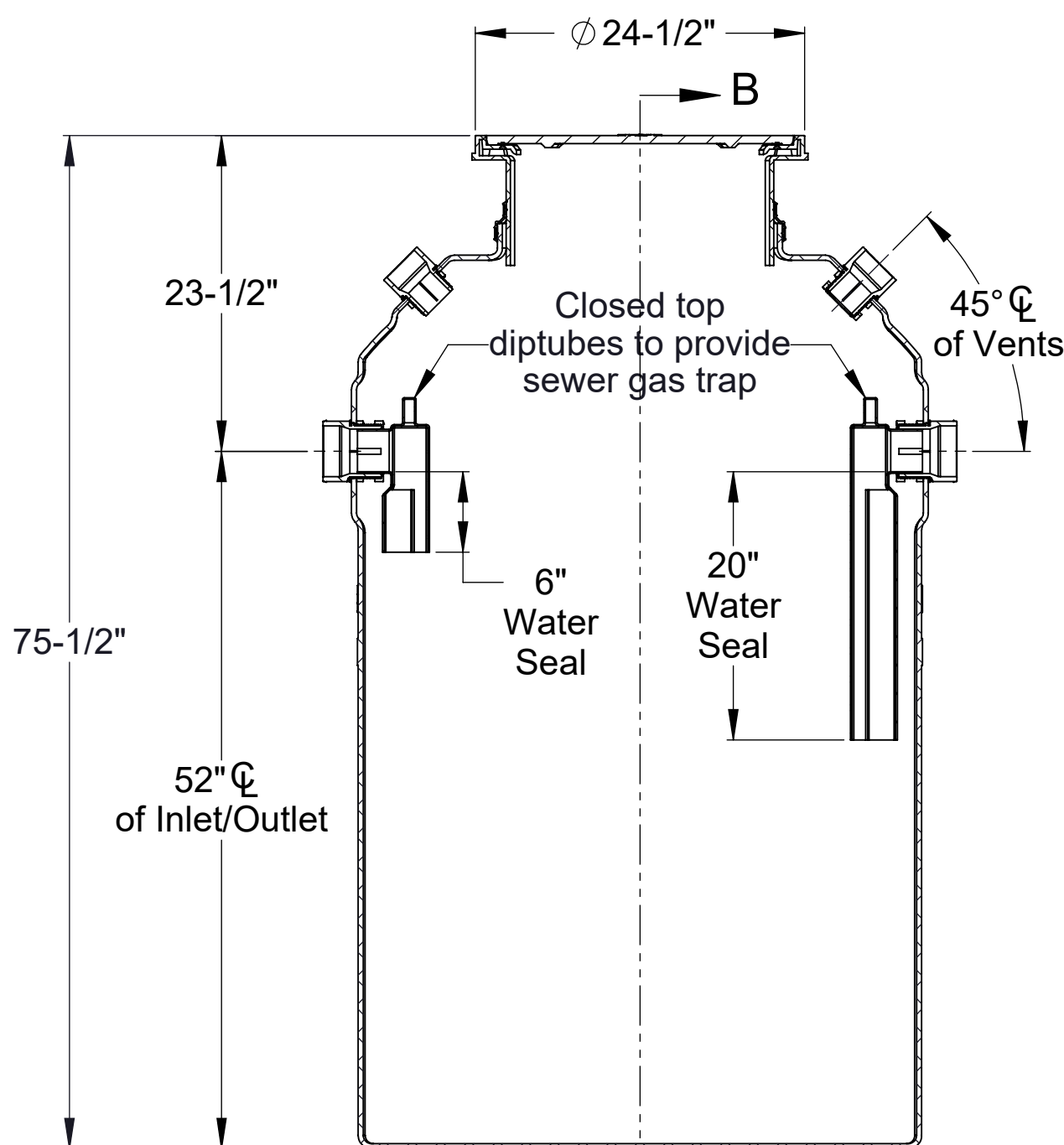

SECTION A-A

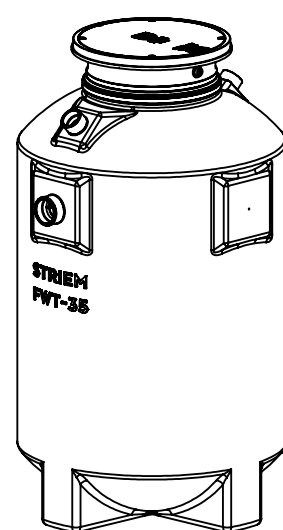

PROPRIETARY AND CONFIDENTIAL
 THE INFORMATION CONTAINED IN THIS DRAWING IS THE SOLE PROPERTY OF STRIEM, LLC.
 ANY REPRODUCTION IN PART OR AS A WHOLE WITHOUT THE WRITTEN PERMISSION OF STRIEM, LLC. IS PROHIBITED.

MODEL NUMBER:	FWT-35-SS
DESCRIPTION:	35 CUBIC FEET POLYETHYLENE FLAMMABLE WASTE TRAP WITH SLICK STICK™ OIL LEVEL MONITORING SYSTEM, UNRATED
DWG BY:	ENG
DATE:	6/4/2024
REV:	1

SPECIFICATION SHEET

Striem
 Kansas City, KS
 Tel: 913-222-1500
 orders@striemco.com
 www.striemco.com

Made in the U.S.A

