

Introducing The World's First

HIGH EFFICIENCY OIL/WATER SEPARATOR SERIES



PRODUCT CATALOG | NO.8

- ✓ OIL SEPARATORS
- ✓ SOLIDS INTERCEPTORS
- ✓ CHEMICAL WASTE TANKS



ABOUT THE COVER



WE LOVE MAKING PLUMBING PRODUCTS...



We formed Striem in 2015 with one idea in mind: dealing with a manufacturer should be like a breath of fresh air. That's why we implemented a simple formula:

- ✓ BUILD QUALITY PRODUCTS,
- ✓ SHIP THEM ON TIME, and
- ✓ PROVIDE DAMN GOOD CUSTOMER SERVICE.

We hope you enjoy working with us.

VINCE ISMERT
Direct: 816-591-9765

GABE ISMERT
Direct: 816-820-5454

TABLE OF CONTENTS

IAPMO IGC 325: A NEW PERFORMANCE STANDARD

- About IAPMO IGC 325: High Efficiency Oil/Water Separators 3

OIL SEPARATORS

- High Efficiency Oil/Water Separators 7
- Oil Tanker™ series 9
- Slick Stick™ oil level monitoring system 11

SOLIDS INTERCEPTORS

- Sidekick™ point-of-use side-access 14
- The Aardvark™ basket-style 15
- Tuff Trough™ washer drain trough..... 17
- Sand interceptors 19

CHEMICAL WASTE TANKS

- Lab Rat™ under counter neutralization tanks..... 22
- Lab Basin™ centralized neutralization tanks 23
- Command Center™ pH monitoring package 24
- Bio Basin™ decontamination tanks 25

SAMPLING PORT

- Inspector™ wastewater sampling port..... 26

ACCESSORIES

- Field-adjustable risers..... 27
- High water table hold down kits 28
- Covers, Limestone 29

OUR OIL SEPARATORS SERVE TWO PURPOSES:

- 1 Protect the native soil and water environment.
- 2 Protect the public sewer infrastructure and waste water treatment plant.

Striem's new lineup of **high efficiency oil/water separators** are the first to achieve both goals. Their seamless, rotationally molded construction prevents oils from leaching into the native environment. And, they are now third-party certified to a minimum 96% efficiency. This is a guarantee that the oil separator will stop nearly all oils from entering the public sewer system.

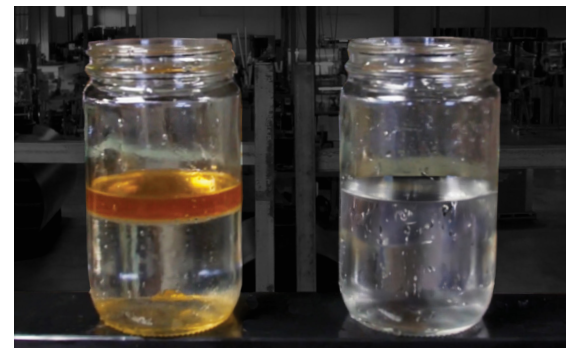

Oily water before and after flowing through a Striem oil separator.



📞 913-222-1500 Talk to a human! ✉️ HELP@STRIEMCO.COM 🌟 STRIEMCO.COM

CUSTOMER SERVICE HOURS: 8 AM - 5 PM CST

ABOUT THE COVER

In addition to creating top-notch products, we're passionate about keeping petroleum oils out of sewers, streams, and soils. Drawing from the company's roots nestled along the confluence of the Kansas and Missouri Rivers, with its vibrant wildlife, Caitlin Knoll, Creative Director at Striem, illustrated this catalog cover featuring the canoe in our logo enjoying a moment of repose.

ABOUT IAPMO IGC 325: HIGH EFFICIENCY OIL/WATER SEPARATORS



In 2022, IAPMO published a new industry standard titled *High Efficiency Oil/Water Separators*. The publication introduced a performance-based standard to the oil separator market and created a new term for the industry: **High Efficiency Oil/Water Separator**.

High Efficiency Oil/Water Separator
A device installed in a drainage system that collects hydrocarbons from wastewater with a minimum 90% capture rate.

What is the full name of the new standard?

IAPMO IGC 325 High Efficiency Oil/Water Separators (referred to herein as 'IGC 325').

Why is this new standard important?

Prior to the publication of IGC 325, **there was no standard** to determine whether or not an oil separator met minimum effluent quality guidelines. Now, manufacturers can subject their oil separators to a rigorous test to determine the efficiency of their product. If the product passes, it may receive a third-party listing and UPC certification from IAPMO.

Do other performance standards exist for oil separators?

No. IGC 325 is the first and only performance standard for oil separators that tests effluent quality. It provides the industry a long-awaited measuring stick to determine how well an oil separator operates.

Does IGC 325 include health and safety design standards?

Yes. In order for a product to pass IGC 325, it must meet material and structural requirements.

What is IGC 325's performance requirement?

The tested oil separator shall separate oil from water at a **minimum of 90% efficiency** at the manufacturer's selected influent flow rate. The influent oil concentration shall be 1,000 mg/L (ppm).

TEST APPARATUS:

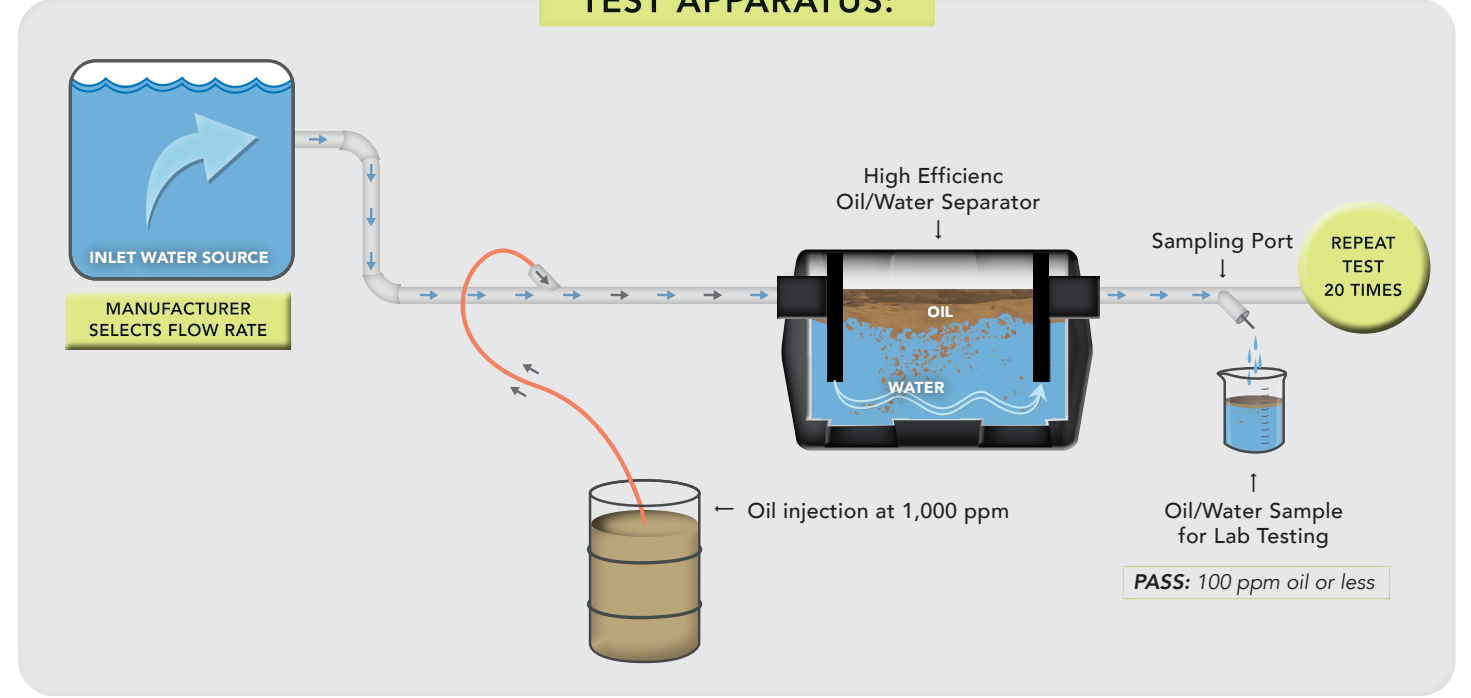

HOW TESTING WORKS:

- STEP 1** Manufacturer selects flow rate and max oil holding capacity for the tested oil separator. The minimum oil holding capacity shall be 25% of the oil separator's total liquid volume.

- STEP 2** Begin the 20-batch test process. Each batch has a duration of 5 minutes. Samples are taken during the final minute of each test batch.

- STEP 3** Oil/water effluent samples are analyzed to EPA Method 1664a by an approved laboratory to determine if the samples pass or fail the efficiency criteria.

Visit pages 7-8 for Striem's full lineup of **High Efficiency Oil/Water Separators**.

OIL SEPARATORS



Oil Tanker™ Series



OS-100



OT-500

STRIEM'S OIL SEPARATOR FOOTPRINT



WATCH HERE:
What is an
Oil Separator?

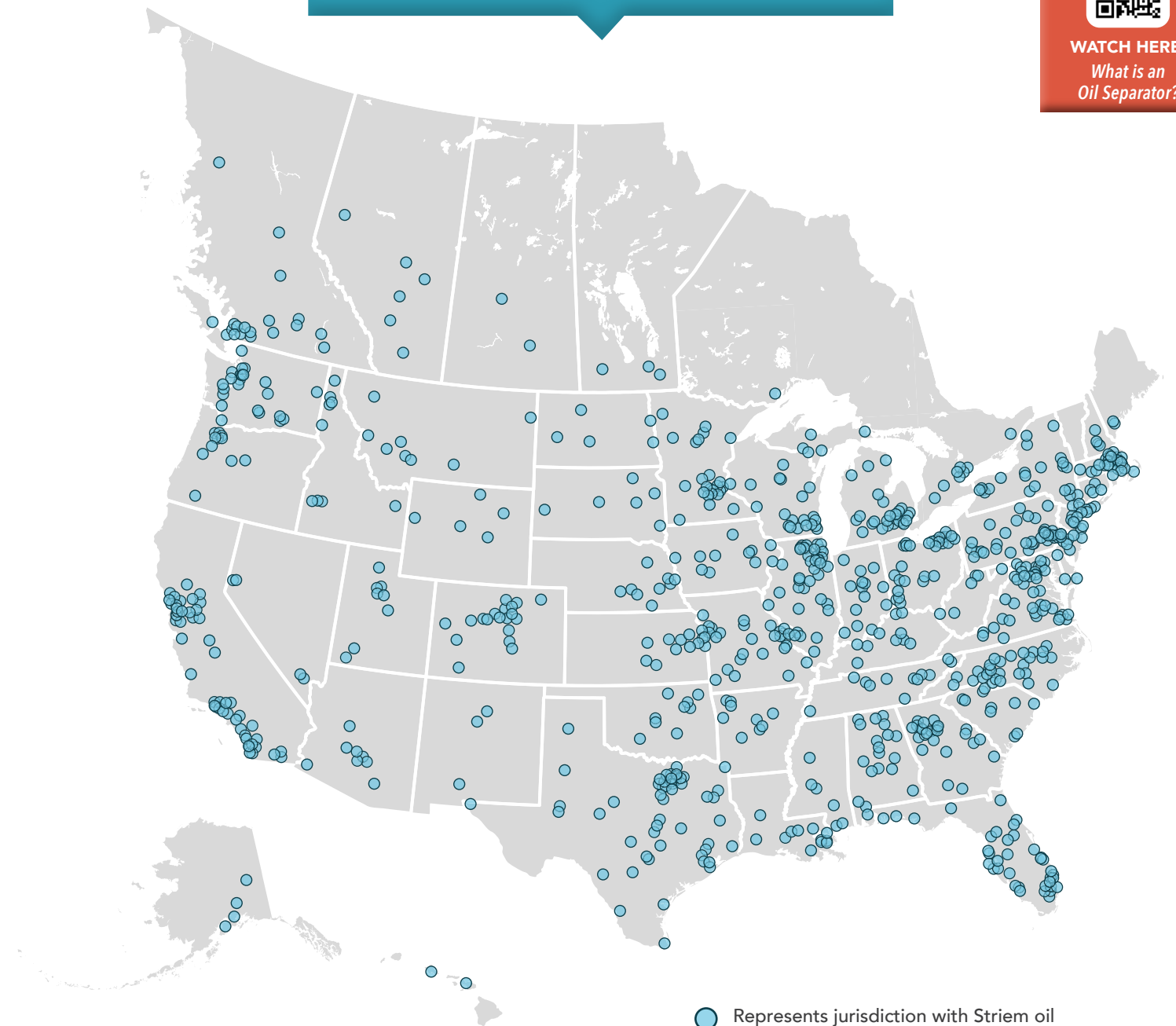

● Represents jurisdiction with Striem oil separator installation(s) since 2016.

APPLICATIONS

Online Sizing Tools available!



AUTO SERVICE/
REPAIR STATIONS

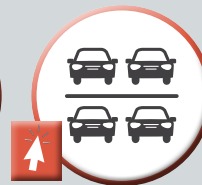

PARKING
GARAGES



FIRE HOUSE/
POLICE STATIONS

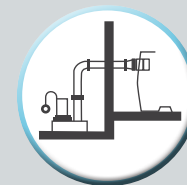

HYDRAULIC
ELEVATOR PITS



CAR WASHES



LOADING
DOCKS



AIRPORTS /
HANGARS



Listed by IAPMO to IGC 325

CHECK OUT OUR ONLINE SIZING TOOL.



AVAILABLE ONLINE FOR ALL PRODUCTS

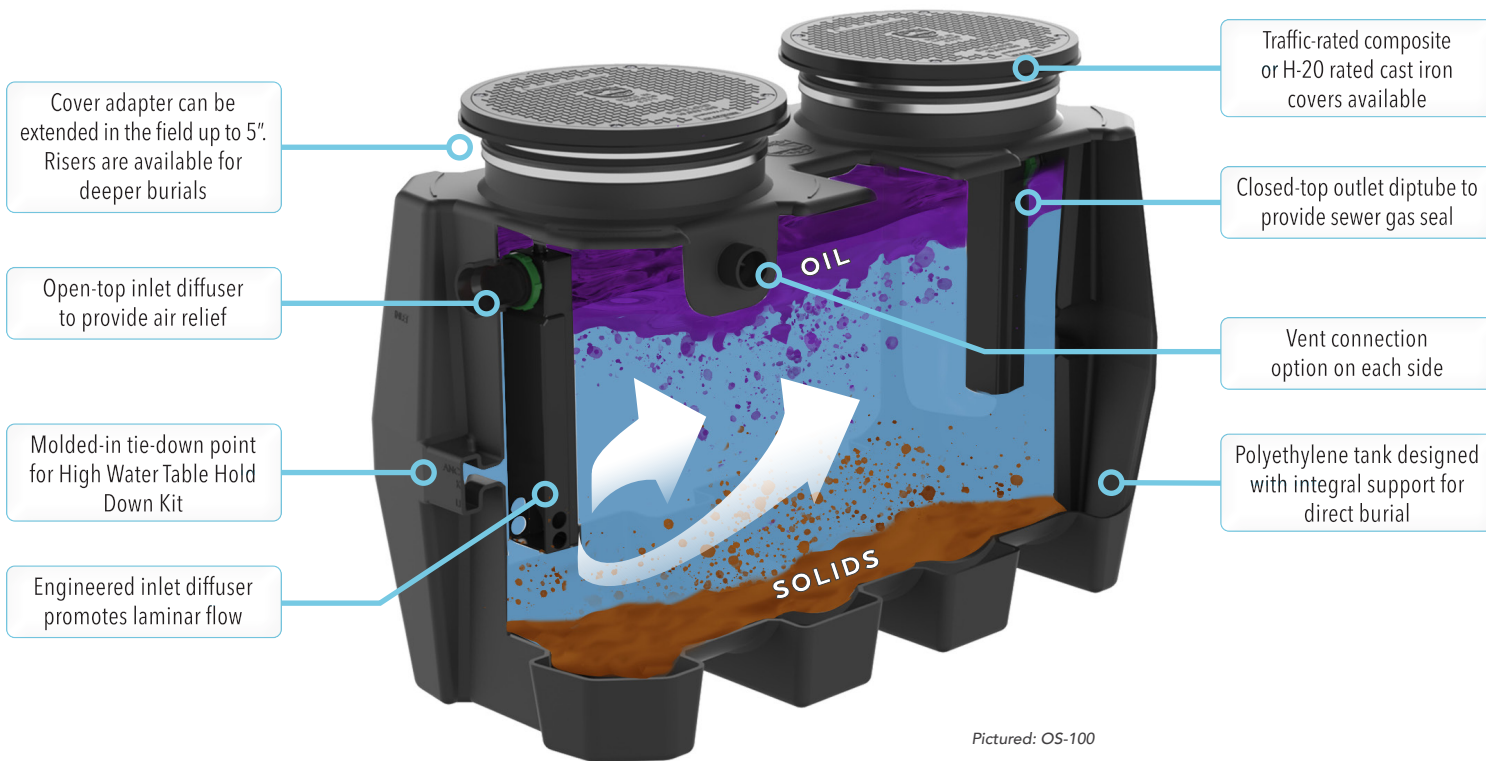

Pictured: OS-100

OPTIONS	
Covers	
TRAF C24-H Traffic-rated bolted composite	CPRK Corrugated Pipe Riser Kit (CPRK)
H-20 C24-HP H-20 rated pickable cast iron	PAGE 27 - Product Details
PAGE 29 - Product Details	HDK High water table hold down kits
SR/LR field-adjustable risers	
16" SR-16	SS Slick Stick™ oil level monitoring system
24" SR-24 / LR-24	PAGE 11 - Product Details
PAGE 27 - Product Details	

- ✓ Certified to IAPMO IGC 325, the industry's first oil separator **performance** standard.
- ✓ Meets EPA hydrocarbon discharge guidance of 100 ppm or less.¹

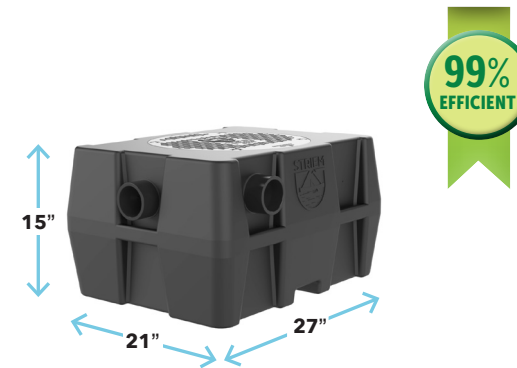

OS-25	OPTIONS → 16"
CONNECTIONS: 3"	SOLIDS CAPACITY: 6 GAL.
LIQUID CAPACITY: 21 GAL.	COVER: PEDESTRIAN-RATED
OIL CAPACITY: 5.25 GAL.	CERTIFIED FLOW RATE: 25 GPM

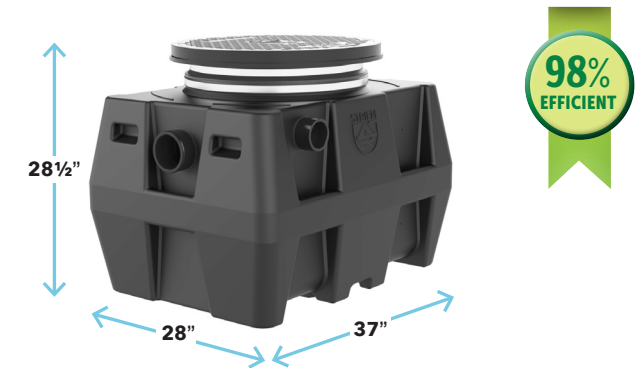

OS-50	OPTIONS → TRAF H-20 24" HDK SS
CONNECTIONS: 4"	SOLIDS CAPACITY: 7 GAL.
LIQUID CAPACITY: 57 GAL.	COVER: PEDESTRIAN-RATED
OIL CAPACITY: 14.25 GAL.	CERTIFIED FLOW RATE: 50 GPM



OS-75	OPTIONS → H-20 24" CPRK HDK SS
CONNECTIONS: 4", 6"	SOLIDS CAPACITY: 11 GAL.
LIQUID CAPACITY: 110 GAL.	COVER: TRAFFIC-RATED
OIL CAPACITY: 27.5 GAL.	CERTIFIED FLOW RATE: 50 GPM



OS-100	OPTIONS → H-20 24" CPRK HDK SS
CONNECTIONS: 4", 6"	SOLIDS CAPACITY: 95 GAL.
LIQUID CAPACITY: 250 GAL.	COVER: TRAFFIC-RATED
OIL CAPACITY: 62.5 GAL.	CERTIFIED FLOW RATE: 75 GPM

Test report and lab sample reports are available on the product webpage or by emailing help@striemco.com.

¹EPA 833-R-04-002A, July 2004

The pretreatment regulations 40 CFR 403.5(b)(6) prohibit the discharge of "petroleum oil, nonbiodegradable cutting oil, or products of mineral oil origin in amounts that will cause interference or pass through."
Most POTWs have adopted 100 mg/L as their local limit for petroleum-based oil and grease because of its history of being protective of the treatment plant and receiving stream.



Listed by IAPMO
to IGC 183-2016



AVAILABLE ONLINE FOR ALL PRODUCTS



WATCH HERE:
Oil Tanker™
Series Spotlight



Pictured: OT-500

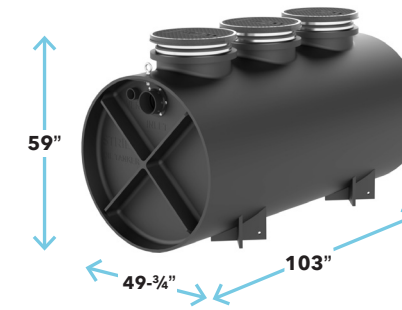

OT-500	OPTIONS	24"	CPRK	HDK	SS
CONNECTIONS: 4", 6", 8"	SOLIDS CAPACITY: 162 GAL.				
LIQUID CAPACITY: 562 GAL.	COVER: CAST IRON (H-20)				
OIL CAPACITY: 285 GAL.					



OT-750	OPTIONS	24"	CPRK	HDK	SS
CONNECTIONS: 4", 6", 8"	SOLIDS CAPACITY: 295 GAL.				
LIQUID CAPACITY: 750 GAL.	COVER: CAST IRON (H-20)				
OIL CAPACITY: 323 GAL.					

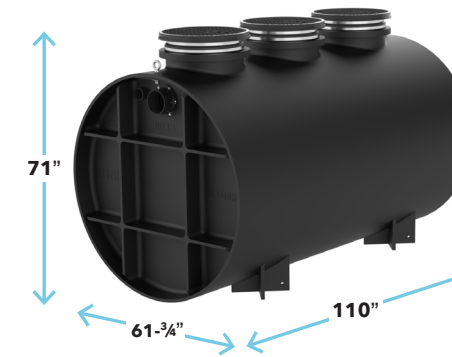

OT-1000	OPTIONS	24"	CPRK	HDK	SS
CONNECTIONS: 4", 6", 8"	SOLIDS CAPACITY: 477 GAL.				
LIQUID CAPACITY: 1,000 GAL.	COVER: CAST IRON (H-20)				
OIL CAPACITY: 370 GAL.					

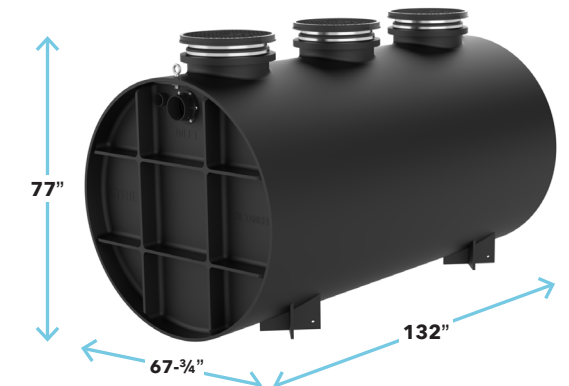

OT-1500	OPTIONS	24"	CPRK	HDK	SS
CONNECTIONS: 4", 6", 8"	SOLIDS CAPACITY: 825 GAL.				
LIQUID CAPACITY: 1,500 GAL.	COVER: CAST IRON (H-20)				
OIL CAPACITY: 488 GAL.					

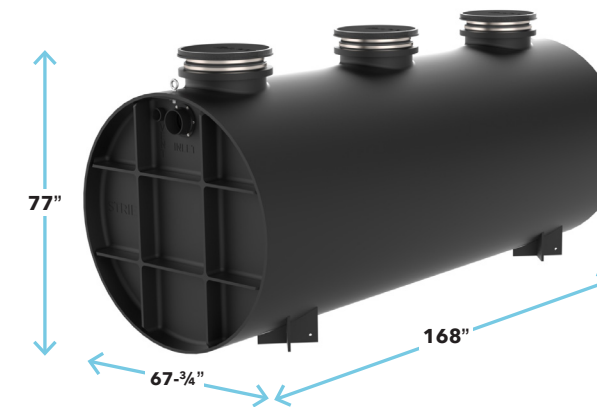

OT-2000	OPTIONS	24"	CPRK	HDK	SS
CONNECTIONS: 4", 6", 8"	SOLIDS CAPACITY: 1,077 GAL.				
LIQUID CAPACITY: 2,000 GAL.	COVER: CAST IRON (H-20)				
OIL CAPACITY: 638 GAL.					

OPTIONS

24" SR-24 / LR-24 field-adjustable risers

PAGE 27 - Product Details

HDK High water table hold down kits

PAGE 28 - Product Details

CPRK Corrugated Pipe Riser Kit (CPRK)

PAGE 27 - Product Details

SS Slick Stick™ oil level monitoring system

PAGE 11 - Product Details



SS

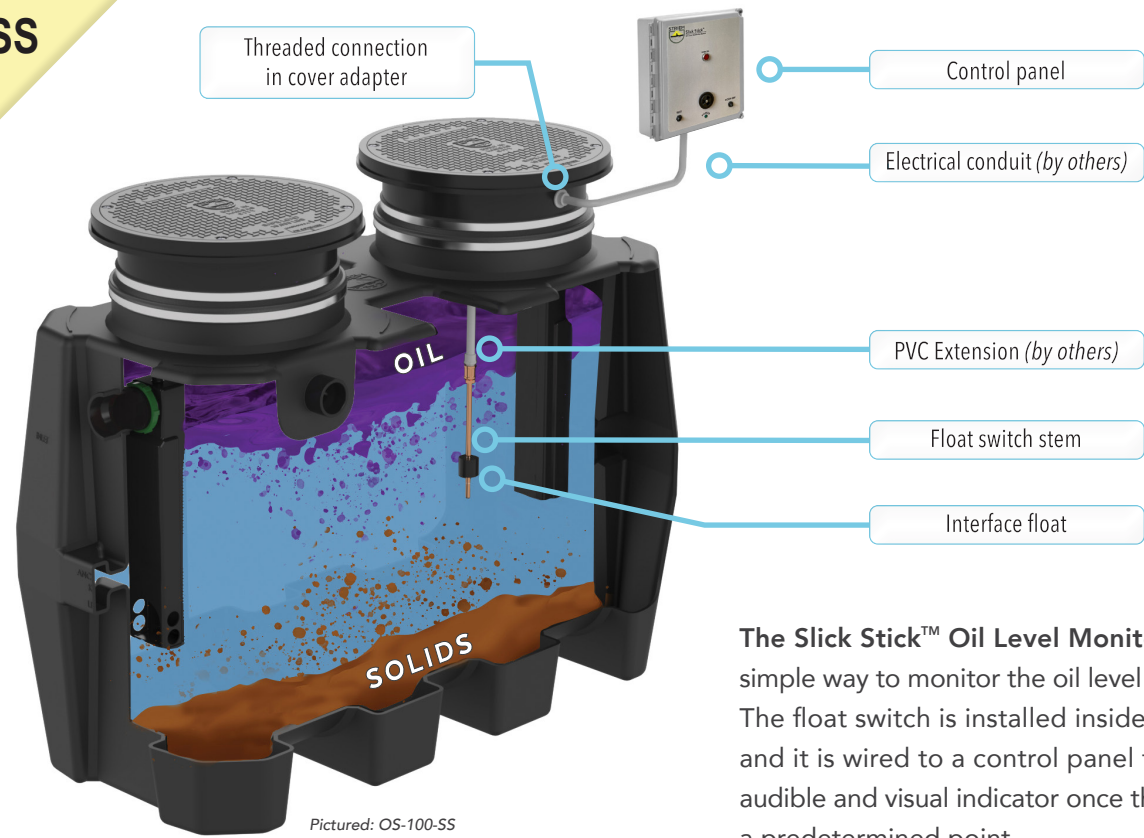

The Slick Stick™ Oil Level Monitoring System is a simple way to monitor the oil level inside the separator. The float switch is installed inside the oil separator, and it is wired to a control panel that provides an audible and visual indicator once the oil level reaches a predetermined point.

Installation with Riser

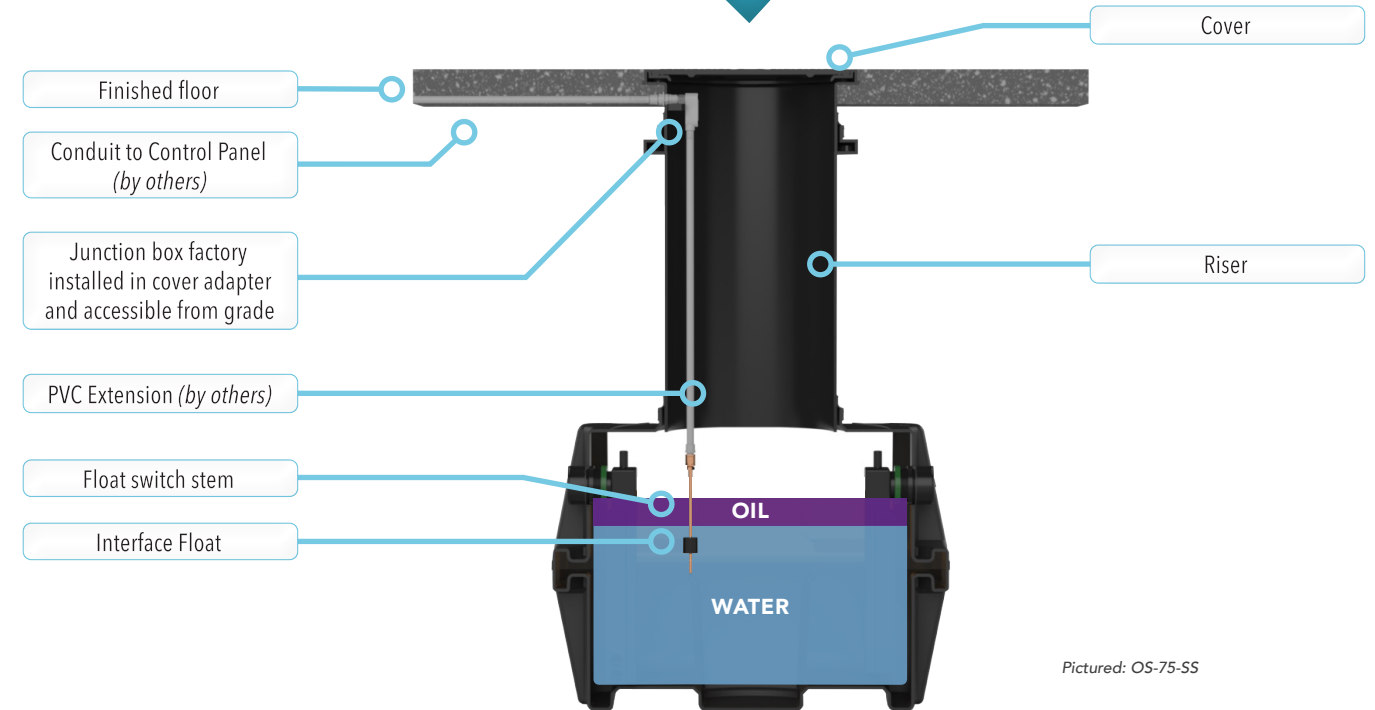

Float is in "UP/OPEN" position in water

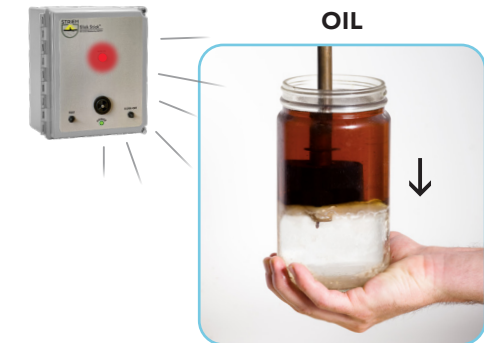

Float is in "DOWN/CLOSED" position in oil, sounding an alarm

MODELS	
OS-50-SS	OT-750-SS
OS-75-SS	OT-1000-SS
OS-100-SS	OT-1500-SS
OT-500-SS	OT-2000-SS

FEATURES
UL listed
Intrinsically safe
Field-extendable interface float
Ability to easily install with risers
Audible and visual alarm
Additional contact for BMS hookup

SPECIFICATIONS	
Provides audio/visual alarm under high oil level condition	"TEST" button tests system electronics
Single phase, 120 VAC, 60 hertz input power required	Locking clasp on door
NEMA 4X enclosure	Intrinsically safe sensor inputs
"HORN OFF" button silences audible alarm	Interface float is buoyant in water, but sinks in the presence of hydrocarbons

SOLIDS INTERCEPTORS



WATCH HERE:
What is a
Solids Interceptor?



Sidekick™



VISIT OUR **SOLIDS INTERCEPTOR**
ONLINE SELECTION TOOL!



Tuff Trough™

POINT-OF-USE SIDE-ACCESS
SOLIDS INTERCEPTOR

SIDEKICK™



Listed by IAPMO
to IGC 167-2011ae2
Pat. No. 11,745,126



WATCH HERE:
The Sidekick™
Spotlight

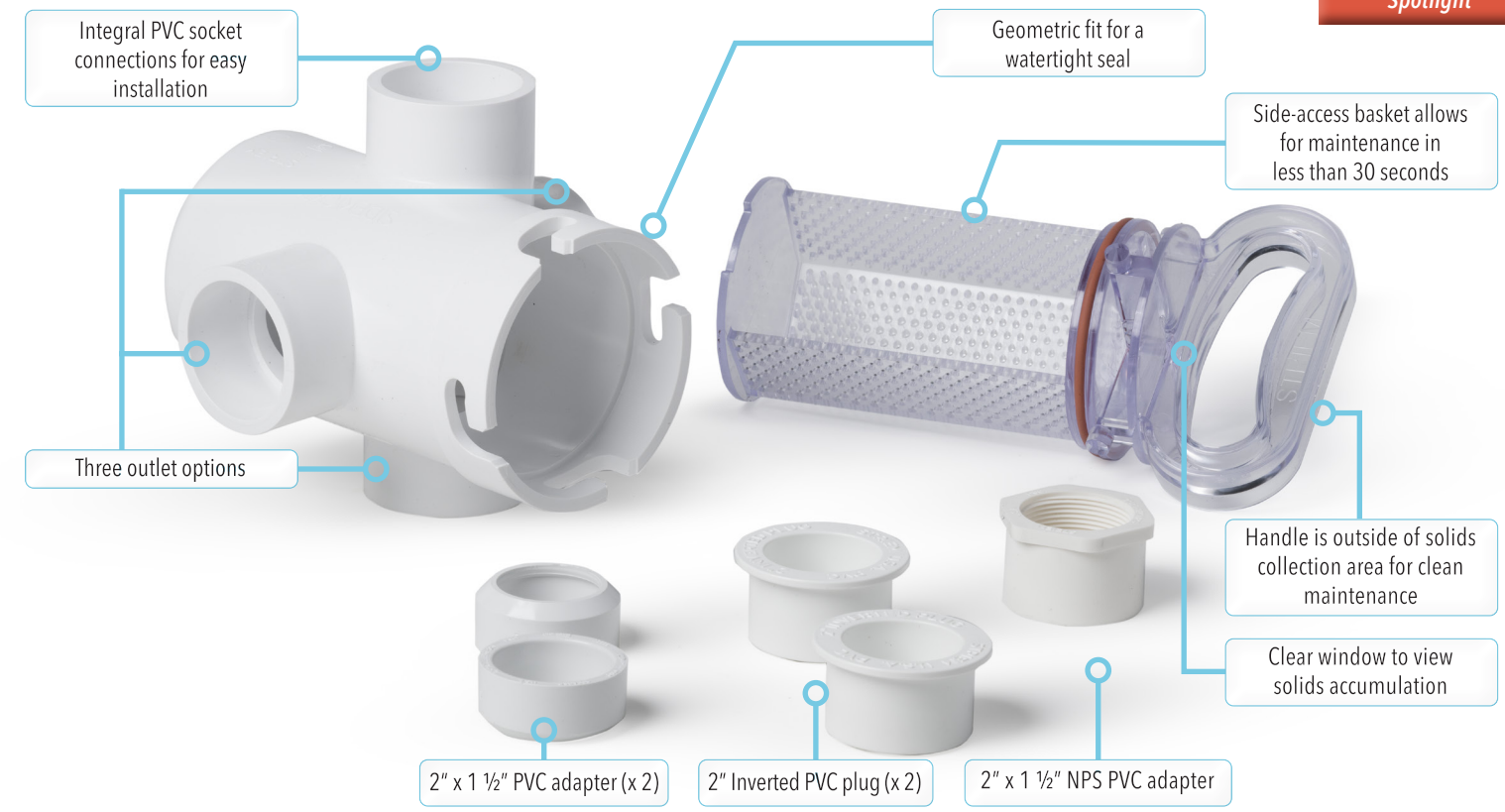

Tamper-proof version

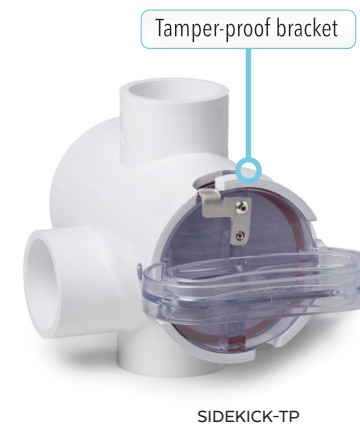

Proprietary "No-Sump plug"

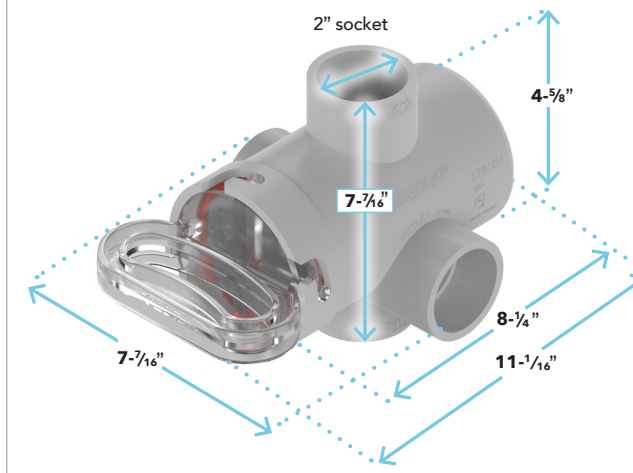

Removes standing water
from unused outlets.

APPLICATIONS



ART ROOM
SINKS



DOG WASH &
PET KENNELS



BARBER SHOPS &
HAIR SALONS



LAUNDRY
FACILITIES

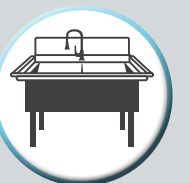

UTILITY SINKS



Listed by IAPMO to
IGC 167-2011ae2
Pat No. 10,786,761



AVAILABLE ONLINE FOR ALL PRODUCTS



WATCH HERE:
The Aardvark™
Spotlight

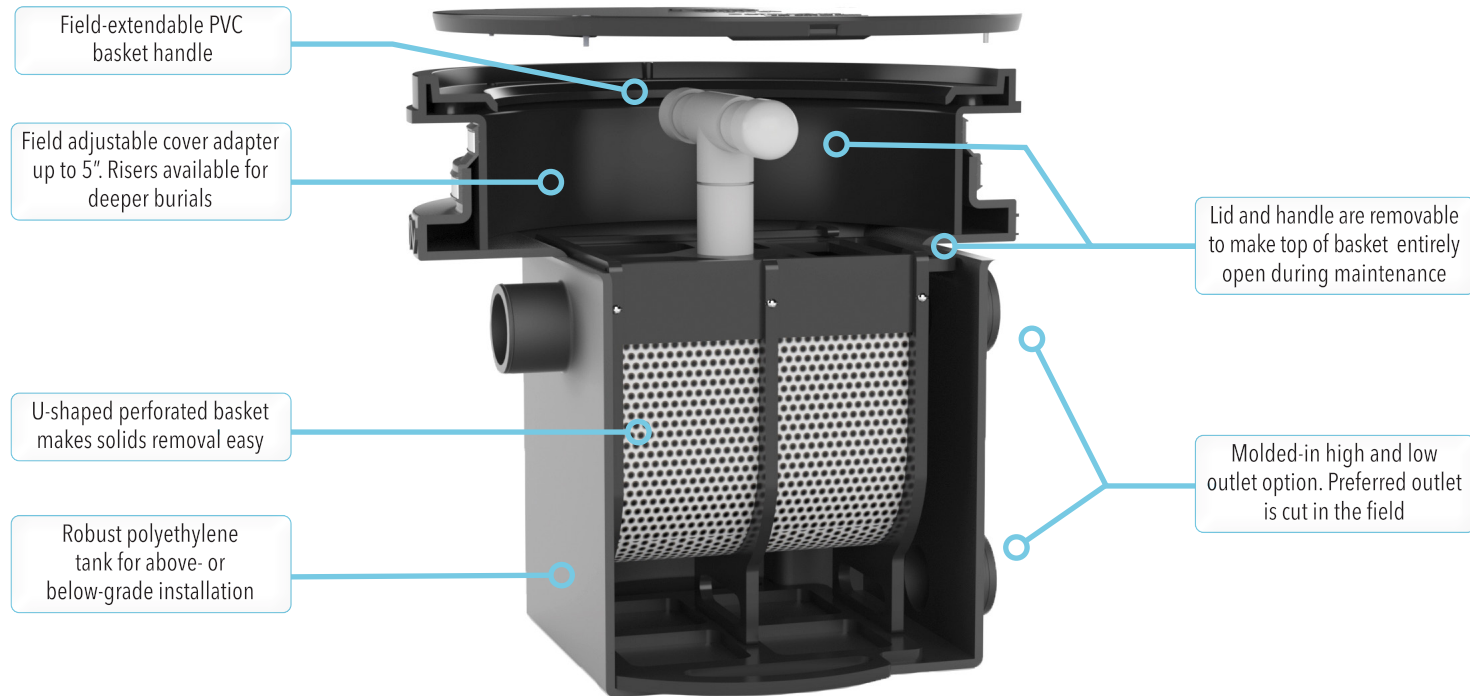

Pictured: AA-3

Same tank & basket with four connection size options:

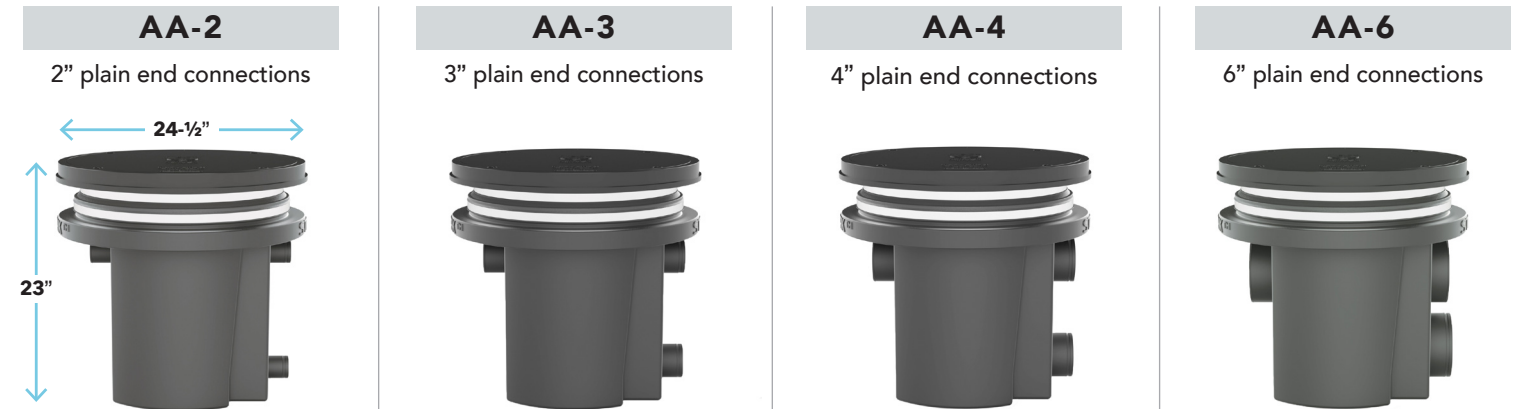

Recommended for DIY maintenance.

OPTIONS

Covers	SR/LR field-adjustable risers	Anchor Flange
<p>TRAF C24-H Traffic-rated bolted composite</p> <p>H-20 C24-HP H-20 rated pickable cast iron</p> <p>PAGE 29 - Product Details</p>	<p>24" SR-24 / LR-24</p> <p>PAGE 27 - Product Details</p>	<p>Integral welded anchor flange at base of tank to provide anti-buoyancy in high water table installation.</p>

APPLICATIONS



ART ROOM
SINKS



DOG WASH &
PET KENNELS



BARBER SHOPS &
HAIR SALONS



LAUNDRY
FACILITIES



UTILITY SINKS

View screen-style interceptors at striemco.com.



Listed by IAPMO to IGC 167-2011ae2



AVAILABLE ONLINE FOR ALL PRODUCTS



WATCH HERE:
Tuff Trough™
Spotlight

A drain trough solves two issues for commercial laundries:

FIRST ISSUE: High Discharge Flow Rate from Washer

The trough acts as a water and suds reservoir. Washer drainage flow rates are high, and can potentially overwhelm a drainage system. A trough provides more open volume to allow water to drain at its natural pace. It also provides air volume for suds to dissipate.

SECOND ISSUE: Drainage System Blockage

The trough has a solids filter near the outlet to block lint, buttons, hair, and coins (among other items) from entering the drainage system and causing a blockage.

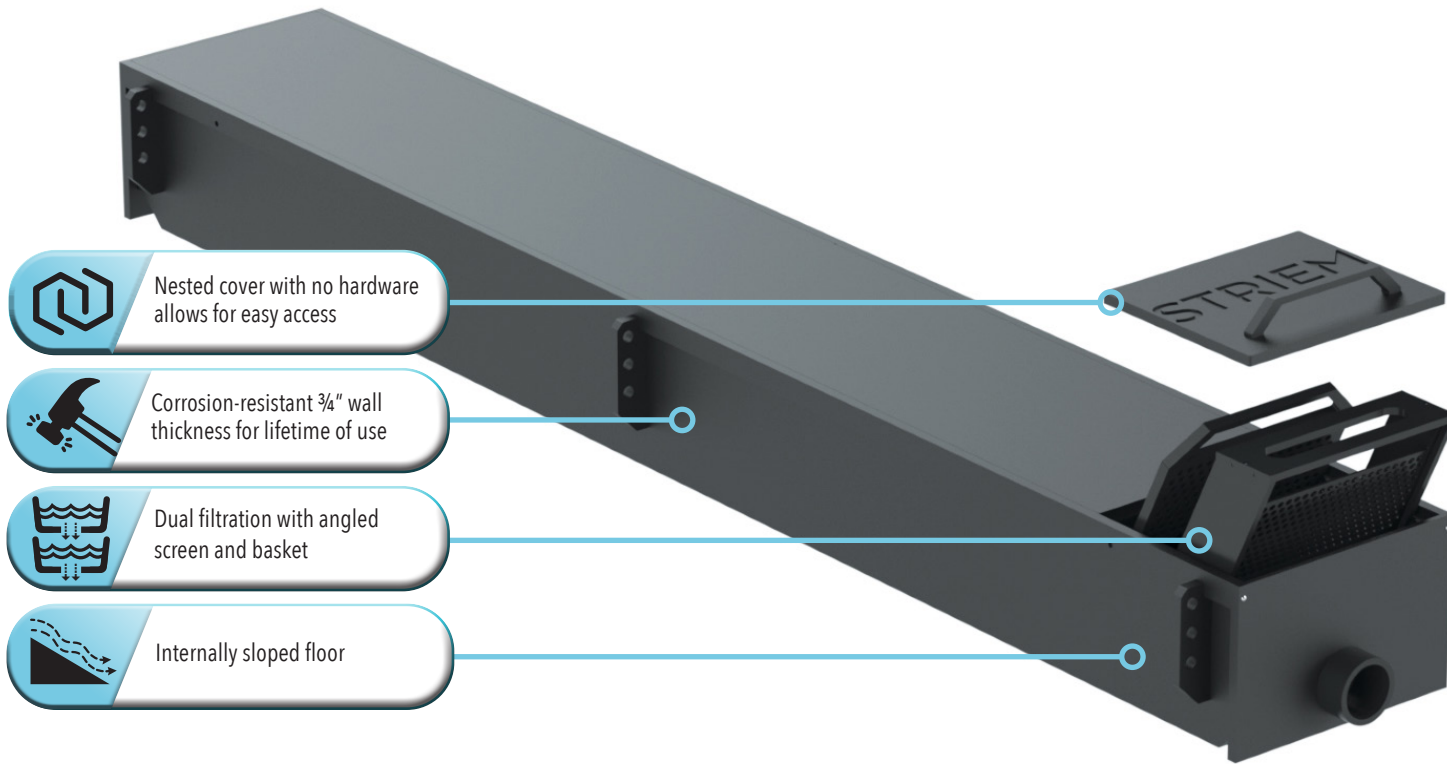

Nested cover with no hardware allows for easy access

Corrosion-resistant 3/4" wall thickness for lifetime of use

Dual filtration with angled screen and basket

Internally sloped floor

Right-sized 1/2" perforations intercept problem-causing debris while allowing water to evacuate efficiently



Install above grade or in the concrete pour



Pictured: TT-3

PRODUCT LINEUP

Model	Dimensions (L x W x H)	Liquid Capacity
TT-3	3' x 18" x 12"	21 gal.
TT-4	4' x 18" x 12"	28 gal.
TT-5	5' x 18" x 12"	34 gal.
TT-6	6' x 18" x 12"	41 gal.
TT-8	8' x 18" x 12"	55 gal.
TT-10	10' x 18" x 12"	68 gal.

INLET BULKHEAD KIT

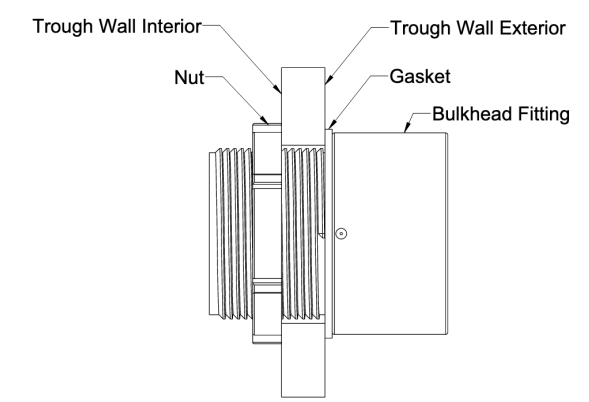

Inlet connections from each washer can be installed in the side or top of the drain trough by the installing contractor. For side connection(s), use Striem's IBK-3 bulkhead fitting kit. This 3" Plain End Inlet Bulkhead Kit (IBK) offers easy, watertight inlet installation.

CHECK OUT OUR ONLINE SIZING TOOL

Washer Size	Quantity	Volume (Gallons)
20 lbs	0	0
30 lbs	1	8.00
40 lbs	0	0
50 lbs	1	13.33
60 lbs	0	0
80 lbs	0	0
90 lbs	0	0
120 lbs	0	0
Volume Total		21.33

Formula for product sizing: TROUGH VOLUME PER WASHER = (WASHER CAPACITY X 0.8) / 3

- Assumptions:
- Water usage factor of 0.8 per lb. of clothing capacity
 - Washer fills and dumps on average three times per cycle

DRAIN TROUGH SIZING CALCULATIONS

SUM OF WASHER SIZES IN LBS.

× 0.8 GAL. WATER USAGE FACTOR PER LB. OF CLOTHING CAPACITY

+ 3 FILL / DUMP CYCLES PER LOAD OF LAUNDRY

TROUGH GALLON CAPACITY

ON-PREMISE LAUNDRY



VENDED LAUNDRY



Grated Covers



CB-50-G OPTIONS 24" HDK
LIQUID CAPACITY: 57 GAL.
COVER: CAST IRON GRATE (H-20)
SOLIDS CAPACITY: 25 GAL.



CB-125-G OPTIONS 24" HDK
LIQUID CAPACITY: 110 GAL.
COVER: CAST IRON GRATE (H-20)
SOLIDS CAPACITY: 70 GAL.

Solid Covers

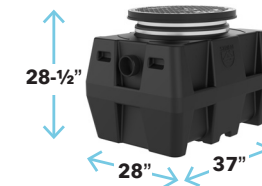

CB-50-S OPTIONS H-20 24" HDK
LIQUID CAPACITY: 57 GAL.
COVER: TRAFFIC-RATED
SOLIDS CAPACITY: 25 GAL.



CB-125-S OPTIONS H-20 24" CPRK HDK
LIQUID CAPACITY: 110 GAL.
COVER: TRAFFIC-RATED
SOLIDS CAPACITY: 70 GAL.

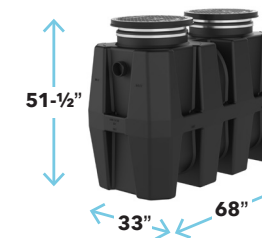

CB-275-S OPTIONS H-20 24" CPRK HDK
LIQUID CAPACITY: 250 GAL.
COVER: TRAFFIC-RATED
SOLIDS CAPACITY: 200 GAL.

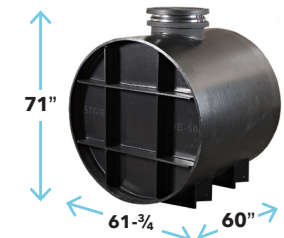

CB-500-S OPTIONS H-20 24" CPRK HDK
LIQUID CAPACITY: 500 GAL.
COVER: TRAFFIC-RATED
SOLIDS CAPACITY: 400 GAL.

Visit striemco.com for larger tank options.

BCB-7 Sediment Basket



OPTIONS

H-20 C24-HP
H-20 rated pickable cast iron cover
PAGE 29 - Product Details

CPRK Corrugated Pipe Riser Kit (CPRK)
PAGE 27 - Product Details

24" SR-24 / LR-24 field-adjustable risers
PAGE 27 - Product Details

HDK High water table hold down kits
PAGE 28 - Product Details

APPLICATIONS



SCRUBBER DUMPS



PARKING GARAGES



LOADING DOCKS



MAINTENANCE FACILITIES



CAR WASHES



GREENHOUSES

CHEMICAL WASTE TANKS



LB-1000



LB-2



Command Center™

POINT-OF-USE
NEUTRALIZATION
TANKS

LAB RAT™ SERIES

RFA DWG PDF CSI
AVAILABLE ONLINE FOR ALL PRODUCTS



WATCH HERE:
Lab Rat™
Series Spotlight

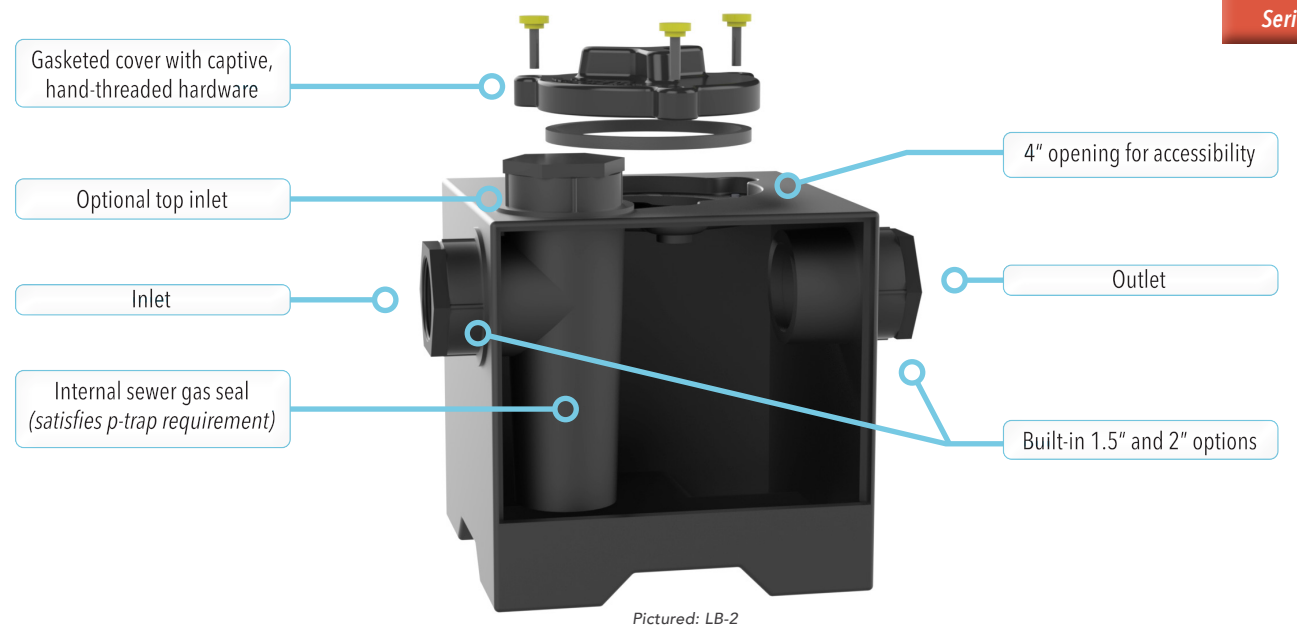

Pictured: LB-2

LB-2
OF LAB SINKS: 1
LIMESTONE LOAD: 25 LBS.
LIQUID CAPACITY: 2 GAL.

LB-2-ADA
OF LAB SINKS: 1
LIMESTONE LOAD: 25 LBS.
LIQUID CAPACITY: 2 GAL.

LB-5
OF LAB SINKS: 2
LIMESTONE LOAD: 50 LBS.
LIQUID CAPACITY: 5 GAL.

APPLICATION LAYOUTS

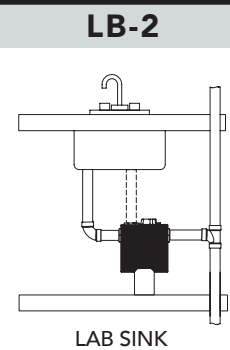

4" PVC pipe for support cut to size (by others)

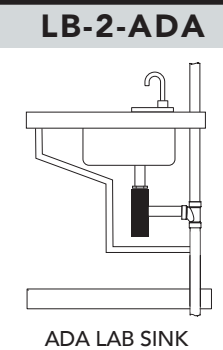

LB-25 **OPTIONS** 16" LS CC-1
OF LAB SINKS: 6 | LIQUID CAPACITY: 21 GAL.

LB-50 **OPTIONS** TRAF 24" HDK LS CC-1
OF LAB SINKS: 15 | LIQUID CAPACITY: 57 GAL.

OPTIONS 24" CPRK HDK LS CC-1

LB-125 # OF LAB SINKS: 35 | LIQUID CAPACITY: 110 GAL.

LB-275 # OF LAB SINKS: 75 | LIQUID CAPACITY: 250 GAL.

LB-500 # OF LAB SINKS: 150 | LIQUID CAPACITY: 500 GAL.

LB-750 # OF LAB SINKS: 215 | LIQUID CAPACITY: 750 GAL.

LB-1000 # OF LAB SINKS: 260 | LIQUID CAPACITY: 1,000 GAL.

LB-1500 # OF LAB SINKS: 375 | LIQUID CAPACITY: 1,500 GAL.

LB-2000 # OF LAB SINKS: 500 | LIQUID CAPACITY: 2,000 GAL.

CHECK OUT OUR ONLINE SIZING TOOL

Acid Neutralization Tank Sizing

Sizing methodology is based on ASPE Plumbing Engineering Design Handbook. Note: Some jurisdictions have a minimum requirement of 5 gallons. Please contact Striem for confirmation.

INPUT:

Number of lab sinks

1 2 3-4

5-6 7-9 10-15

16-35 36-75 76-150

151-215 216-260 261-375

376-500

GENERATE

RECOMMENDATIONS:

Centralized Option:
LB-25
— \$1,800 list —



Specifications PDF DWG
Revit RFA
VIEW PRODUCT

— OR —

Standard point-of-use Option:
LB-2 (1 per standard lab sink)
— \$350 list —



Specifications PDF DWG
Revit RFA
VIEW PRODUCT

ADA point-of-use Option:
LB-2-ADA (1 per ADA lab sink)
— \$620 list —



Specifications PDF DWG
Revit RFA
VIEW PRODUCT

OPTIONS

<p>TRAF C24-H Traffic-rated bolted composite cover</p> <p>PAGE 29 - Product Details</p>	<p>CPRK Corrugated Pipe Riser Kit (CPRK)</p> <p>PAGE 27 - Product Details</p>	<p>LS Limestone</p> <p>PAGE 29 - Product Details</p>
<p>SR/LR field-adjustable risers</p> <p>16" 24"</p> <p>SR-16 SR-24 / LR-24</p> <p>PAGE 27 - Product Details</p>	<p>HDK High water table hold down kits</p> <p>PAGE 28 - Product Details</p>	<p>CC-1 Command Center pH Monitoring System</p> <p>PAGE 24 - Product Details</p>

CC-1

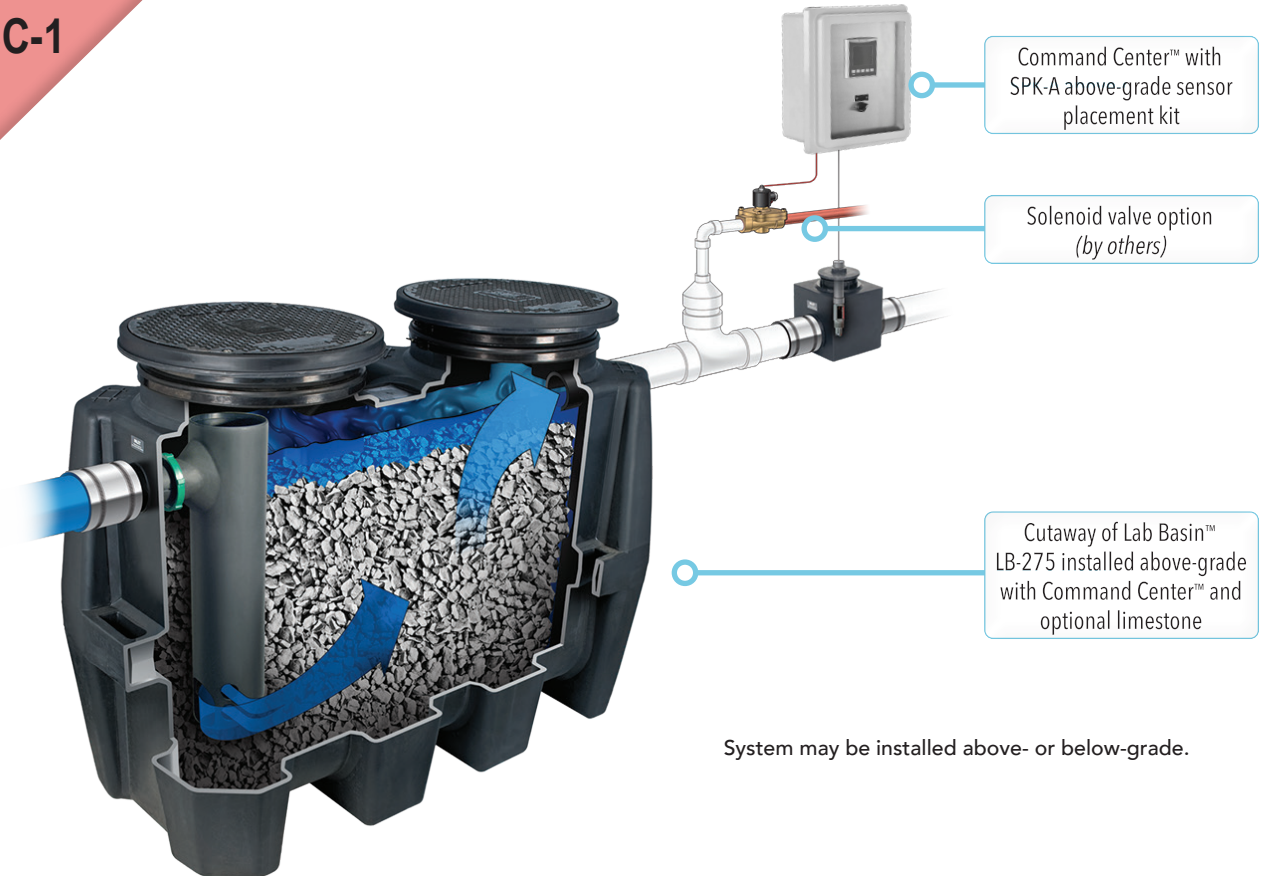

System may be installed above- or below-grade.



Clear front panel



Touchscreen interface (50' cable included)

SPECIFICATIONS

Ethernet connection for BMS hookup	Storage: Includes (2), 1-year micro SD cards
Pre-programmed audio/visual alarm set points	Nema 4x lockable weather proof enclosure -32°F to 122°F
3.5" color touchscreen display	120V AC power supply required
Pre-programmed digital output to power solenoid valve for fresh water to flush if pH approaches high/low limits	

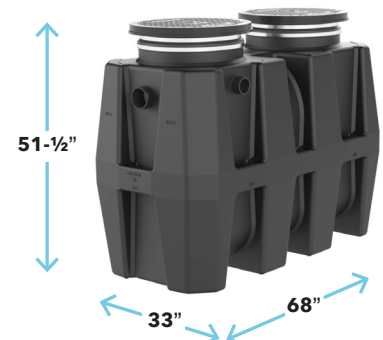

BB-275 OPTIONS 24" CPRK HDK

CONNECTIONS: 2", 3", 4", 6"
LIQUID CAPACITY: 250 GAL.
COVER: TRAFFIC-RATED

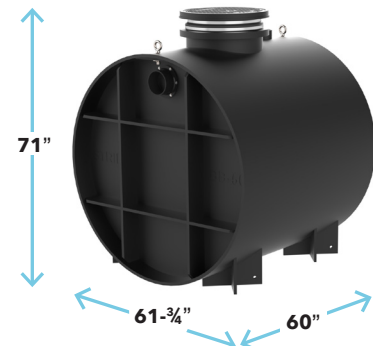

BB-500 OPTIONS 24" CPRK HDK

CONNECTIONS: 3", 4", 6"
LIQUID CAPACITY: 500 GAL.
COVER: TRAFFIC-RATED

Visit striemco.com for larger tank options.

MONITORING PACKAGES:

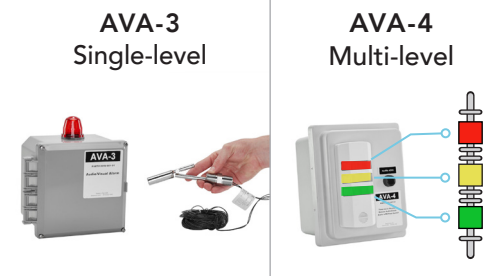

OPTIONS

- 24"** SR-24 / LR-24 field-adjustable risers
[PAGE 27 - Product Details](#)
- CPRK** Corrugated Pipe Riser Kit (CPRK)
[PAGE 27 - Product Details](#)
- HDK** High water table hold down kits
[PAGE 28 - Product Details](#)

SIZING

Striem recommends these steps for sizing a decontamination tank:

$$\left[\begin{array}{c} \text{Number} \\ \text{of Fixtures} \\ \text{(showers or} \\ \text{eyewash stations)} \end{array} \right] \times \left[\begin{array}{c} \text{Supply Line} \\ \text{Flow Rate of} \\ \text{Each Fixture} \end{array} \right] \times \left[\begin{array}{c} \text{Rinse Time} \\ \text{(15-20 minutes} \\ \text{typical)} \end{array} \right] = \text{SIZE OF TANK IN GALLONS}$$

Sizing Sample:

1. A hospital with two emergency showers, each with a 3/4" supply line carrying a flow rate of 9.96 GPM. 2 fixtures x 9.96 GPM = 19.92 GPM
2. 19.92 GPM x 15 minutes = 298.8 gallons
3. Select Bio Basin™ model BB-500 (500 liquid holding gallons)



WATCH HERE:
The Inspector™
Spotlight

INSPECTOR-4

4" connections



INSPECTOR-6

6" connections



SPECIFICATIONS

Unit supplied with built-in adapter for up to 5" adjustability	Lightweight and easy to install
Additional riser(s) available for deeper burial depth	Maximum operating temperature 140° F
Polyethylene construction	Highway rated (16,000 lb. load) bolted, gas/water tight composite cover. (H-20 cast iron available)

16" SR-16

For use with tanks with 16" cover



24" SR-24

SHORT RISER
For use with tanks with 24" cover



LR-24

LONG RISER
For use with tanks with 24" cover



WATCH HERE:
How to Install a Riser

SR-24 & LR-24 Risers are stackable.

Tilt adapter up to 6.5° in any direction to match grade.



CPRK

CPRK Corrugated Pipe Riser Kit

Uses 18" Inner Diameter ADS N-12 Dual Wall HDPE Pipe (by others)



WATCH HERE:
CPRK Installation



Cost-effective option for deeper burials &/or on tanks with multiple manways.

HDK



HDK-2

Compatible with:

- OS-50, OS-75, OS-100
- PS-50-S, PS-125-S, PS-275-S
- CB-50-S, CB-125-S, CB-275-S, CB-50-G, CB-125-G
- SI-UPC-1016
- LB-50, LB-125, LB-275
- BB-275

HDK-3



Compatible with:

- OT-500

HDK-4



Compatible with:

- OT-750
- CB-750-S
- LB-750
- BB-750

HDK-5



Compatible with:

- OT-1000
- CB-1000-S
- LB-1000
- BB-1000

HDK-6



Compatible with:

- OT-1500
- CB-1500-S
- LB-1500
- BB-1500

HDK-7

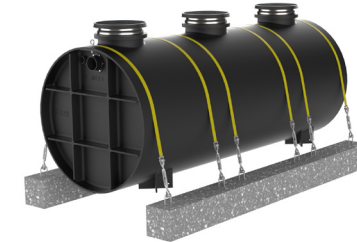

Compatible with:

- OT-2000
- CB-2000-S
- LB-2000
- BB-2000

HDK-8



Compatible with:

- CB-500-G
- CB-500-S
- LB-500
- BB-500

COVERS



	C16-M	C24-M	C24-H	C24-HP
LOCATION:	INDOOR	INDOOR	INDOOR / OUTDOOR	OUTDOOR
DIAMETER:	16"	24"	24"	24"
TYPE:	BOLTED POLYPROPYLENE	BOLTED COMPOSITE	BOLTED COMPOSITE	PICKABLE CAST IRON
LOAD RATING:	2,500 LBS.	2,000 LBS.	16,000 LBS.	16,000 LBS. H-2O RATED

LIMESTONE

LS



- 90% or greater calcium carbonate content
- 1" - 3" in size
- 25 lbs. and 50 lbs. options available



OUR TEAM + OUR PHILOSOPHY

Be **happier** this year than last



ADD VALUE



TAKE THE LONG VIEW



TRUST is more important than PRICE



GROW SLOWLY



Maintain your health **PHYSICALLY & EMOTIONALLY**

Stay within our CAPABILITIES



Believe people are **INHERENTLY GOOD**

913-222-1500 | HELP@STRIEMCO.COM | STRIEMCO.COM

Manufacturing in Kansas City, KS