



---

# PRODUCT **Nº 7** CATALOG

---

**PROUD MANUFACTURERS OF:**

OIL SEPARATORS | SOLIDS INTERCEPTORS | CHEMICAL WASTE TANKS



## TABLE OF CONTENTS

### OIL SEPARATORS

- OS series .....7
- Oil Tanker™ series .....9
- Slick Stick™ oil level monitoring system ..... 11

### SOLIDS INTERCEPTORS

- Sidekick™ point-of-use side-access ..... 14
- Tuff Trough™ washer drain trough ..... 15
- Aardvark™ basket-style ..... 17
- Sand interceptors ..... 19

### CHEMICAL WASTE TANKS

- Lab Rat™ under counter neutralization tanks .. 22
- Lab Basin™ centralized neutralization tanks ... 23
- Command Center™ pH monitoring package... 25
- Bio Basin™ decontamination tanks ..... 26

### SAMPLING PORT

- Inspector™ wastewater sampling port ..... 27

### ACCESSORIES

- Field-adjustable risers ..... 28
- High water table hold down kits ..... 29
- Covers, Limestone, Coalescing Media ..... 30

#### WE LOVE MAKING PLUMBING PRODUCTS.

We formed Striem in 2015 with one idea in mind: dealing with a manufacturer should be like a breath of fresh air. That's why we implemented a simple formula:

- ✓ Build quality products,
- ✓ Ship them on time, and
- ✓ Provide damn good customer service.

We hope you enjoy working with us.

**VINCE ISMERT**  
Direct: 816-591-9765

**GABE ISMERT**  
Direct: 816-820-5454



STRIEM VIDEOS

📞 913-222-1500 *Talk to a human!*

✉️ [HELP@STRIEMCO.COM](mailto:HELP@STRIEMCO.COM) 🌐 [STRIEMCO.COM](http://STRIEMCO.COM)

CUSTOMER SERVICE HOURS: 8 AM - 5 PM CST

# OUR PHILOSOPHY

Maintain your HEALTH... physically and emotionally 



ADD VALUE

Take the long view

TRUST 

is more important than PRICE



Be HAPPIER  this year than last

GROW SLOWLY 



Stay within our CAPABILITIES

Believe people are INHERENTLY GOOD 

# OIL SEPARATORS



**FUN FACT**

STRIEM'S OIL TANKER™ SERIES IS THE **INDUSTRY'S FIRST CERTIFIED** POLYETHYLENE OIL SEPARATOR LINEUP.

Oil Tanker™ Series



OS-100



OT-500

**STRIEM'S OIL SEPARATOR FOOTPRINT**

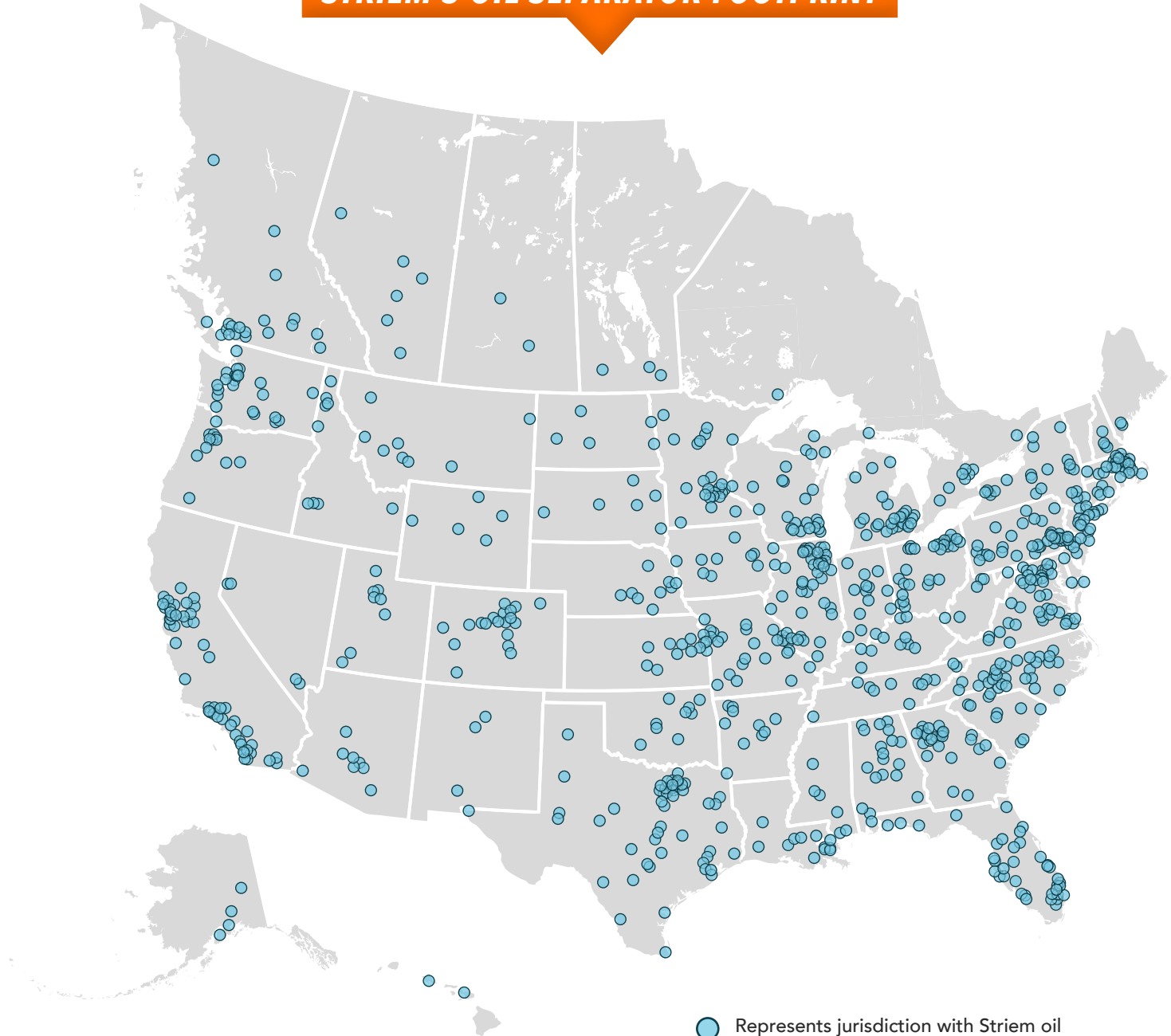

● Represents jurisdiction with Striem oil separator installation(s) since 2016.

**APPLICATIONS**



AUTO SERVICE/  
REPAIR STATIONS



FIRE HOUSE/  
POLICE STATIONS



PARKING  
GARAGES

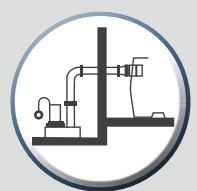

HYDRAULIC  
ELEVATOR PITS



CAR WASHES



LOADING  
DOCKS



AIRPORTS /  
HANGARS

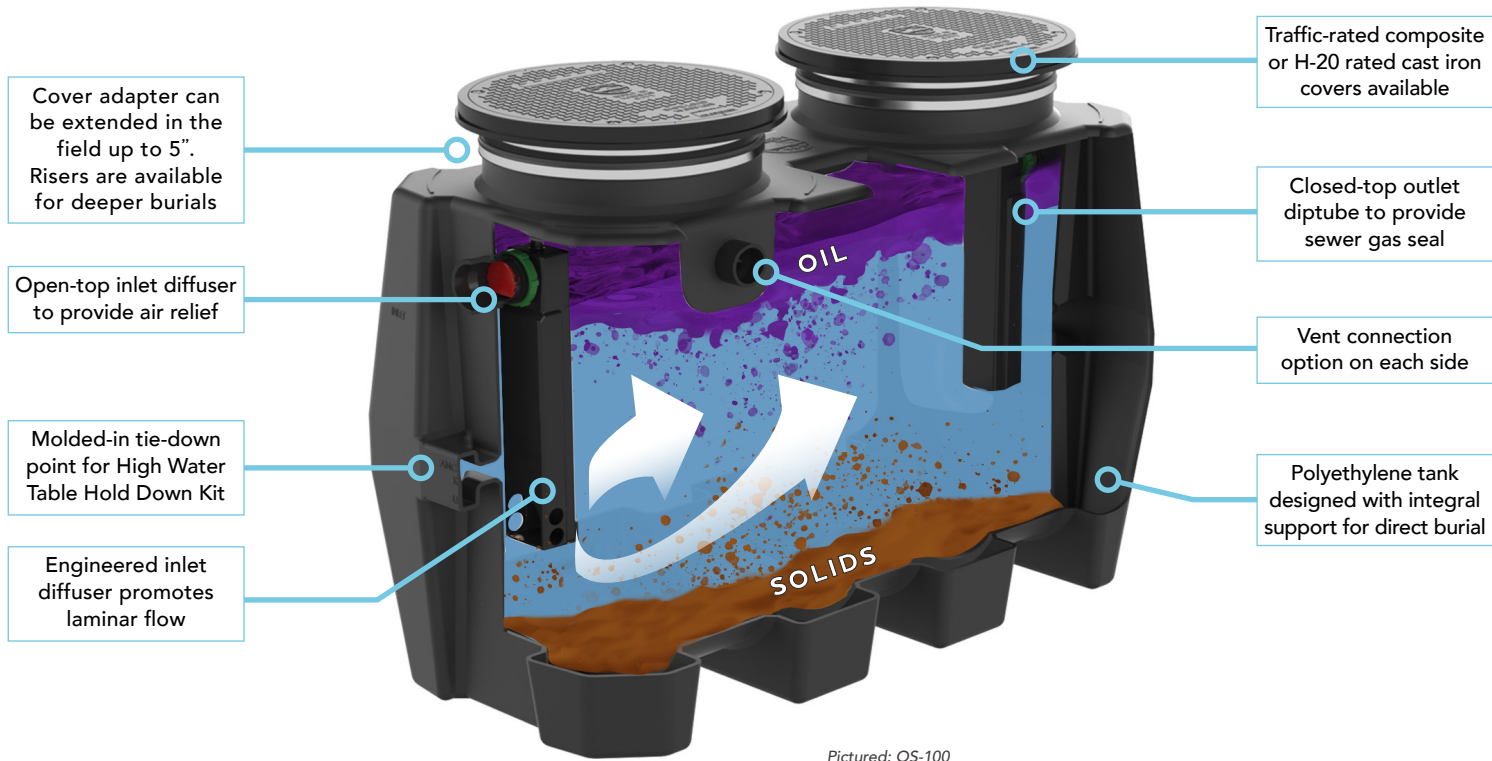

Pictured: OS-100

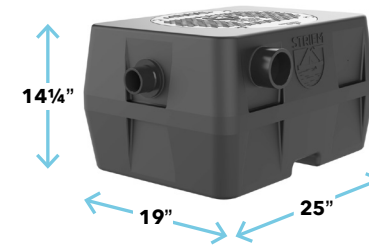

<b>OS-15</b>	OPTIONS	16"
CONNECTIONS: 2", 3"	SAND CAPACITY: 1 GAL.	
LIQUID CAPACITY: 15 GAL.	COVER: PEDESTRIAN-RATED	
OIL CAPACITY: 10 GAL.		

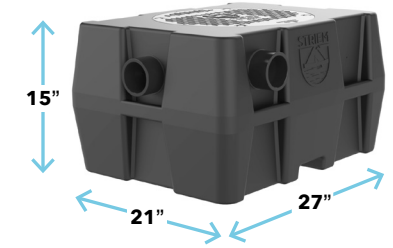

<b>OS-25</b>	OPTIONS	16"
CONNECTIONS: 2", 3"	SAND CAPACITY: 6 GAL.	
LIQUID CAPACITY: 21 GAL.	COVER: PEDESTRIAN-RATED	
OIL CAPACITY: 15 GAL.		

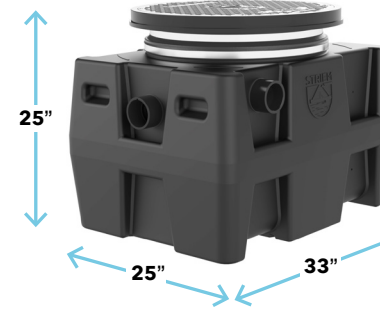

<b>OS-35</b>	OPTIONS	24" CS
CONNECTIONS: 2", 3", 4"	SAND CAPACITY: 6 GAL.	
LIQUID CAPACITY: 38 GAL.	COVER: PEDESTRIAN-RATED	
OIL CAPACITY: 28 GAL.		

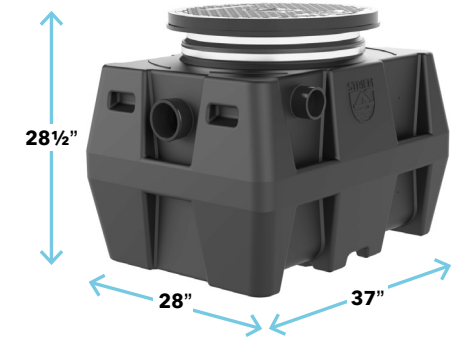

<b>OS-50</b>	OPTIONS	TRAF H-20 24" HDK SS CS
CONNECTIONS: 2", 3", 4"	SAND CAPACITY: 7 GAL.	
LIQUID CAPACITY: 57 GAL.	COVER: PEDESTRIAN-RATED	
OIL CAPACITY: 40 GAL.		

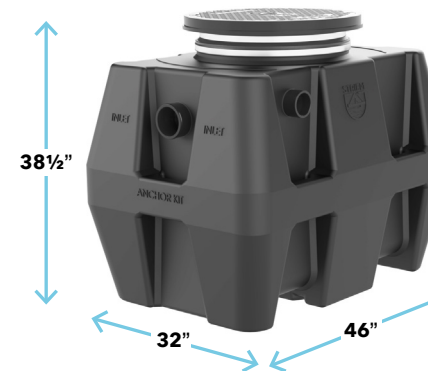

<b>OS-75</b>	OPTIONS	H-20 24" CPRK HDK SS CS
CONNECTIONS: 4", 6"	SAND CAPACITY: 11 GAL.	
LIQUID CAPACITY: 110 GAL.	COVER: TRAFFIC-RATED	
OIL CAPACITY: 93 GAL.		

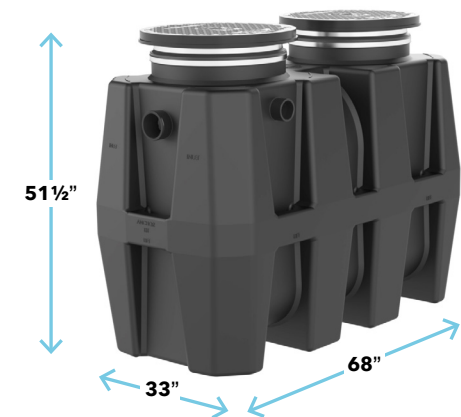

<b>OS-100</b>	OPTIONS	H-20 24" CPRK HDK SS CS
CONNECTIONS: 4", 6"	SAND CAPACITY: 95 GAL.	
LIQUID CAPACITY: 250 GAL.	COVER: TRAFFIC-RATED	
OIL CAPACITY: 144 GAL.		

## OPTIONS

### Covers

TRAF

C24-H  
Traffic-rated  
bolted composite

Page 30 - product details

H-20

C24-HP  
H-20 rated  
pickable cast iron

CPRK

Corrugated Pipe Riser Kit (CPRK)

Page 28 - product details

HDK

High water table hold down kits

Page 29 - product details

SS

Slick Stick™ oil level monitoring system

Page 11 - product details

CS

Coalescing Media

Page 30 - product details

### SR/LR field-adjustable extensions

16"

SR-16

24"

SR-24 / LR-24

Page 28 - product details

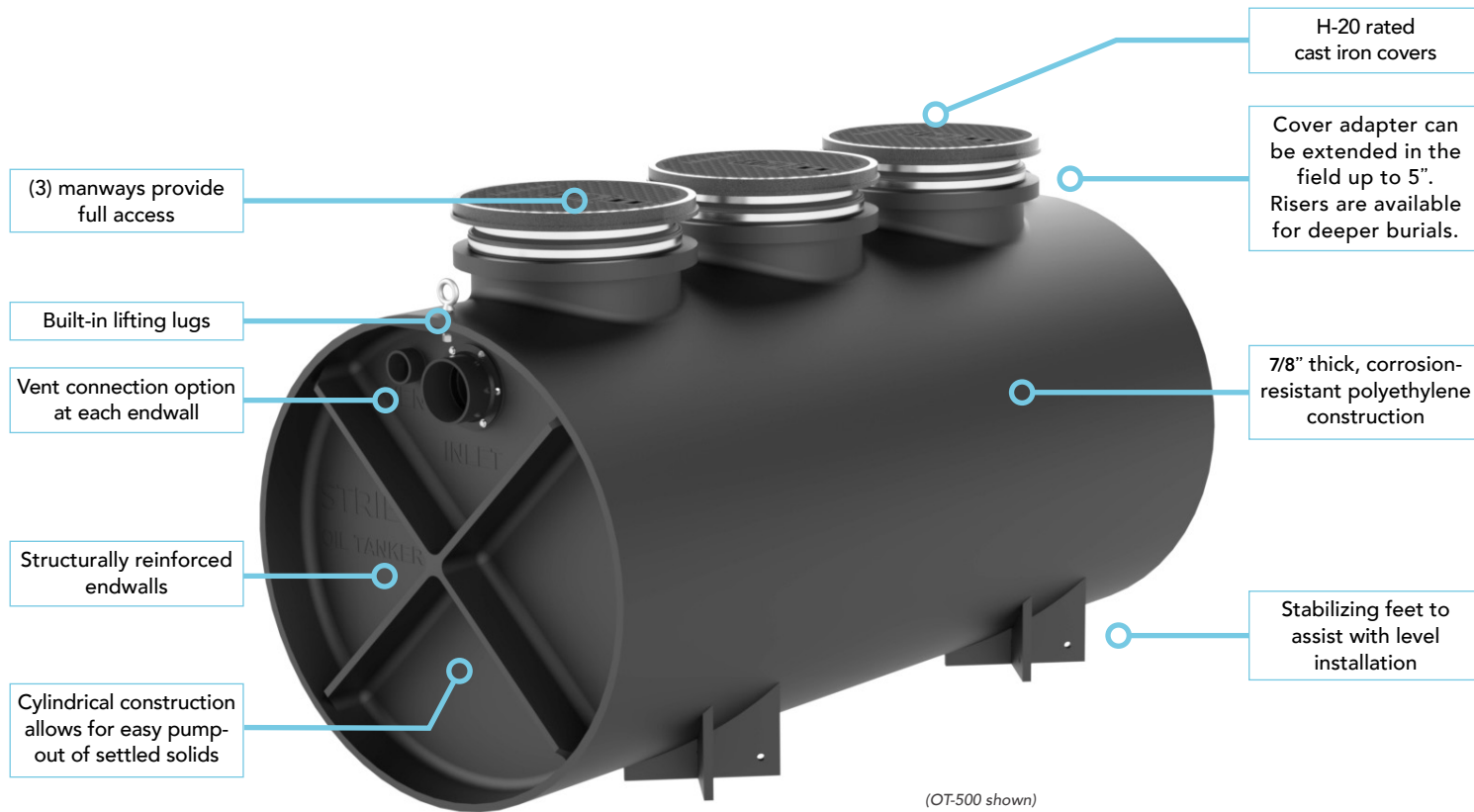

(3) manways provide full access

Built-in lifting lugs

Vent connection option at each endwall

Structurally reinforced endwalls

Cylindrical construction allows for easy pump-out of settled solids

H-20 rated cast iron covers

Cover adapter can be extended in the field up to 5". Risers are available for deeper burials.

7/8" thick, corrosion-resistant polyethylene construction

Stabilizing feet to assist with level installation

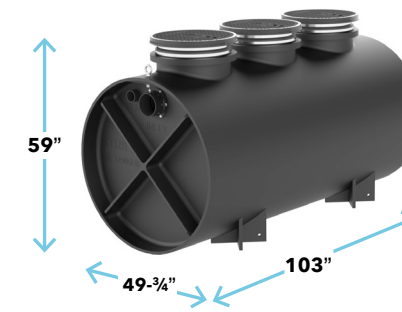

<b>OT-500</b>	OPTIONS	24"	CPRK	HDK	SS	CS
CONNECTIONS: 4", 6", 8"	SAND CAPACITY: 162 GAL.					
LIQUID CAPACITY: 562 GAL.	COVER: CAST IRON (H-20)					
OIL CAPACITY: 285 GAL.						

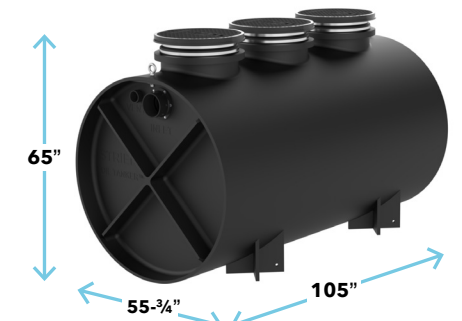

<b>OT-750</b>	OPTIONS	24"	CPRK	HDK	SS	CS
CONNECTIONS: 4", 6", 8"	SAND CAPACITY: 295 GAL.					
LIQUID CAPACITY: 750 GAL.	COVER: CAST IRON (H-20)					
OIL CAPACITY: 323 GAL.						

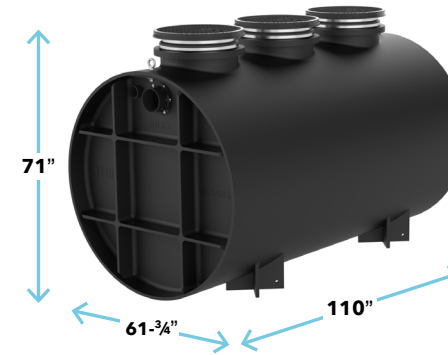

<b>OT-1000</b>	OPTIONS	24"	CPRK	HDK	SS	CS
CONNECTIONS: 4", 6", 8"	SAND CAPACITY: 477 GAL.					
LIQUID CAPACITY: 1,000 GAL.	COVER: CAST IRON (H-20)					
OIL CAPACITY: 370 GAL.						

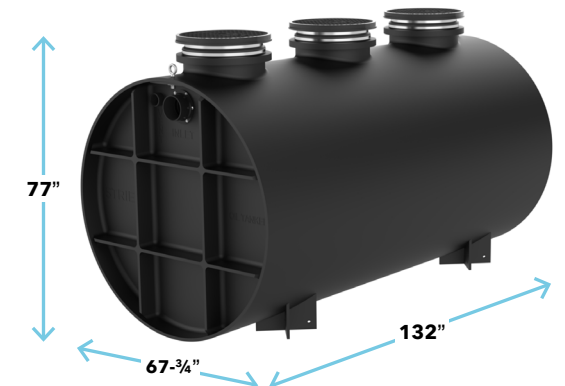

<b>OT-1500</b>	OPTIONS	24"	CPRK	HDK	SS	CS
CONNECTIONS: 4", 6", 8"	SAND CAPACITY: 825 GAL.					
LIQUID CAPACITY: 1,500 GAL.	COVER: CAST IRON (H-20)					
OIL CAPACITY: 488 GAL.						

## OPTIONS

### SR/LR field-adjustable extensions

**24"** SR-24 / LR-24

Page 28 - product details

**CPRK** Corrugated Pipe Riser Kit (CPRK)

Page 28 - product details

**HDK** High water table hold down kits

Page 29 - product details

**SS** Slick Stick™ oil level monitoring system

Page 11 - product details

**CS** Coalescing Media

Page 30 - product details

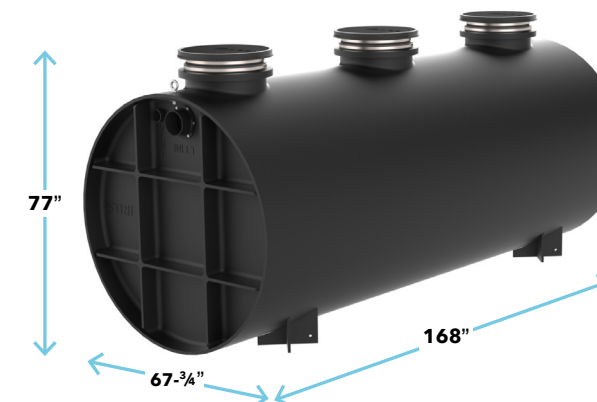

<b>OT-2000</b>	OPTIONS	24"	CPRK	HDK	SS	CS
CONNECTIONS: 4", 6", 8"	SAND CAPACITY: 1,077 GAL.					
LIQUID CAPACITY: 2,000 GAL.	COVER: CAST IRON (H-20)					
OIL CAPACITY: 638 GAL.						

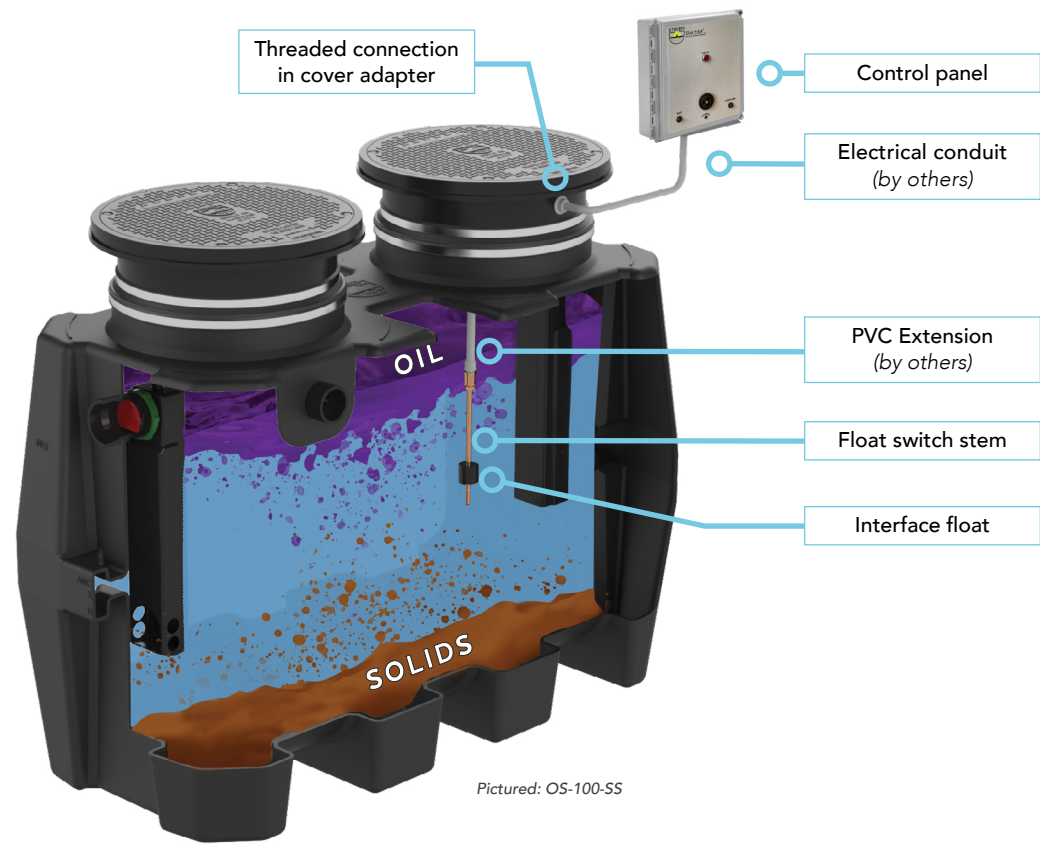

The Slick Stick™ Oil Level Monitoring System is a simple way to monitor the oil level inside the separator. The float switch is installed inside the oil separator, and it is wired to a control panel that provides an audible and visual indicator once the oil level reaches a predetermined point.

## INSTALLATION WITH RISER

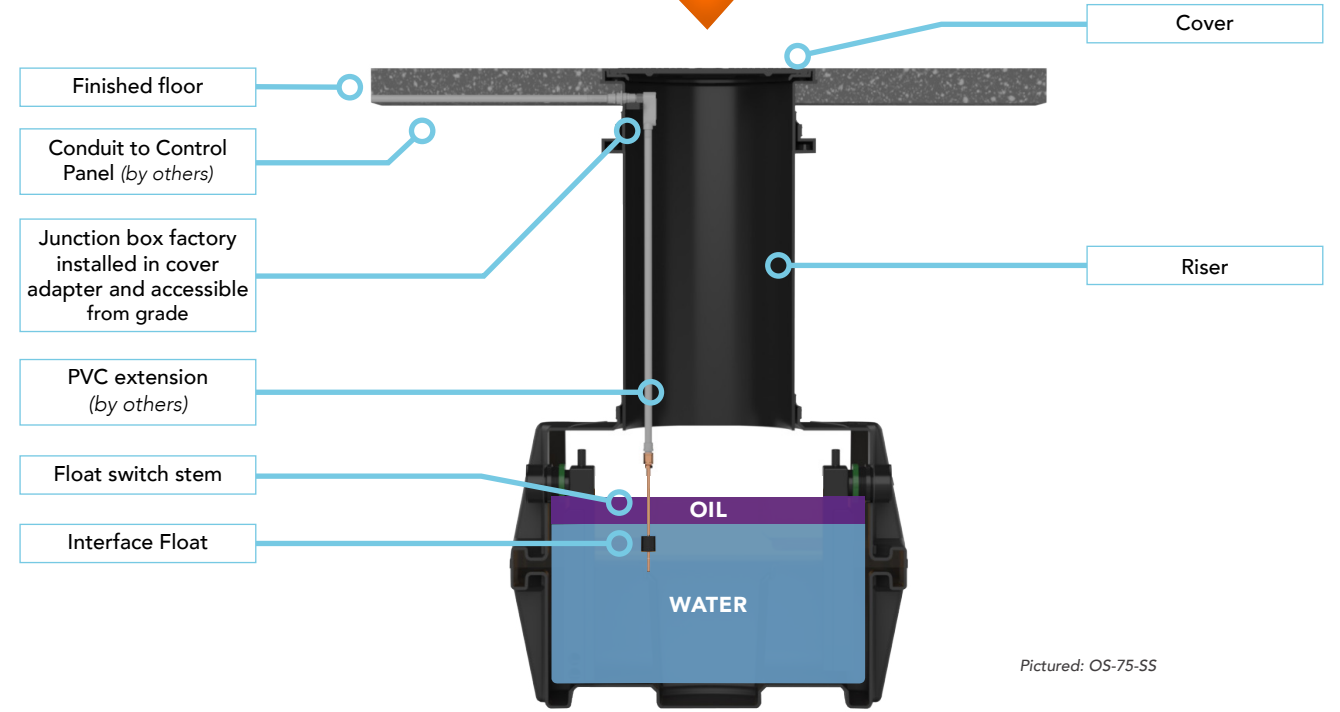

Control panel & float switch



Cover adapter with conduit connection & junction box



Float is in "UP/OPEN" position in water

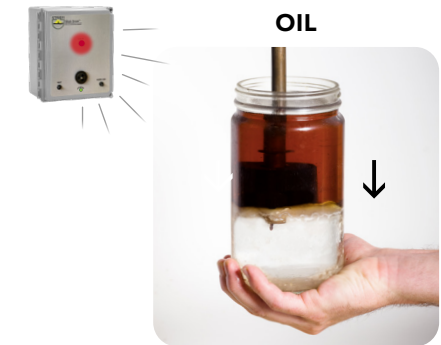

Float is in "DOWN/CLOSED" position in oil, sounding an alarm

MODELS	
OS-50-SS	OT-750-SS
OS-75-SS	OT-1000-SS
OS-100-SS	OT-1500-S
OT-500-SS	OT-2000-SS

FEATURES
UL listed
Intrinsically safe
Field-extendable interface float
Ability to easily install with risers
Audible and visual alarm
BMS capability

## SPECIFICATIONS

Provides audio/visual alarm under high oil level condition	"TEST" button tests system electronics
Single phase, 120 VAC, 60 hertz input power required	Locking clasp on door
NEMA 4X enclosure	Intrinsically safe sensor inputs
"HORN OFF" button silences audible alarm	Interface float is buoyant in water, but sinks in the presence of hydrocarbons

# SOLIDS INTERCEPTORS



## FUN FACT

STRIEM'S SIDEKICK™ IS THE **INDUSTRY'S ONLY** POINT-OF-USE, SIDE-ACCESS SOLIDS INTERCEPTOR.

Sidekick™



Tuff Trough™



Aardvark™

POINT-OF-USE SIDE-ACCESS SOLIDS INTERCEPTOR



**SIDEKICK™**



Listed by IAPMO to IGC 167-2011ae2 Pat. No. 11,745,126



Integral PVC socket connections for easy installation

Three outlet options

RFA DWG PDF CSI  
AVAILABLE ONLINE FOR ALL PRODUCTS

2" x 1 1/2" PVC adapter (x2)

2" Inverted PVC plug (x2)

2" x 1 1/2" NPS PVC adapter

Geometric fit for a watertight seal

Side-access basket allows for maintenance in less than 30 seconds

Handle is outside of solids collection area for clean maintenance

Clear window to view solids accumulation

### TAMPER-PROOF VERSION

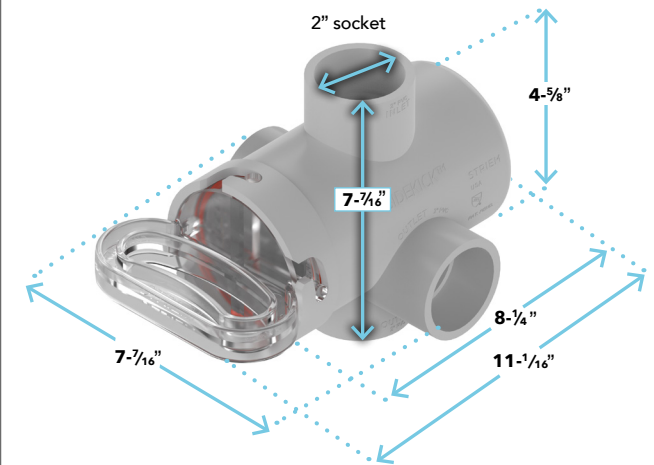
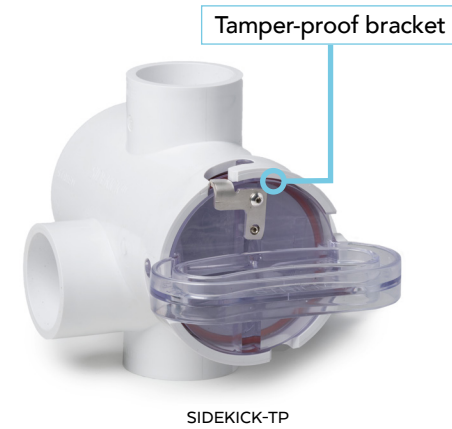

### PART UPGRADE



New "no sump" outlet plugs to remove standing water.

### APPLICATIONS



ART ROOM SINKS



DOG WASH & PET KENNELS



BARBER SHOPS & HAIR SALONS



COMMERCIAL KITCHENS



LAUNDRY FACILITIES

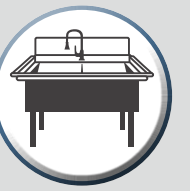

UTILITY SINKS



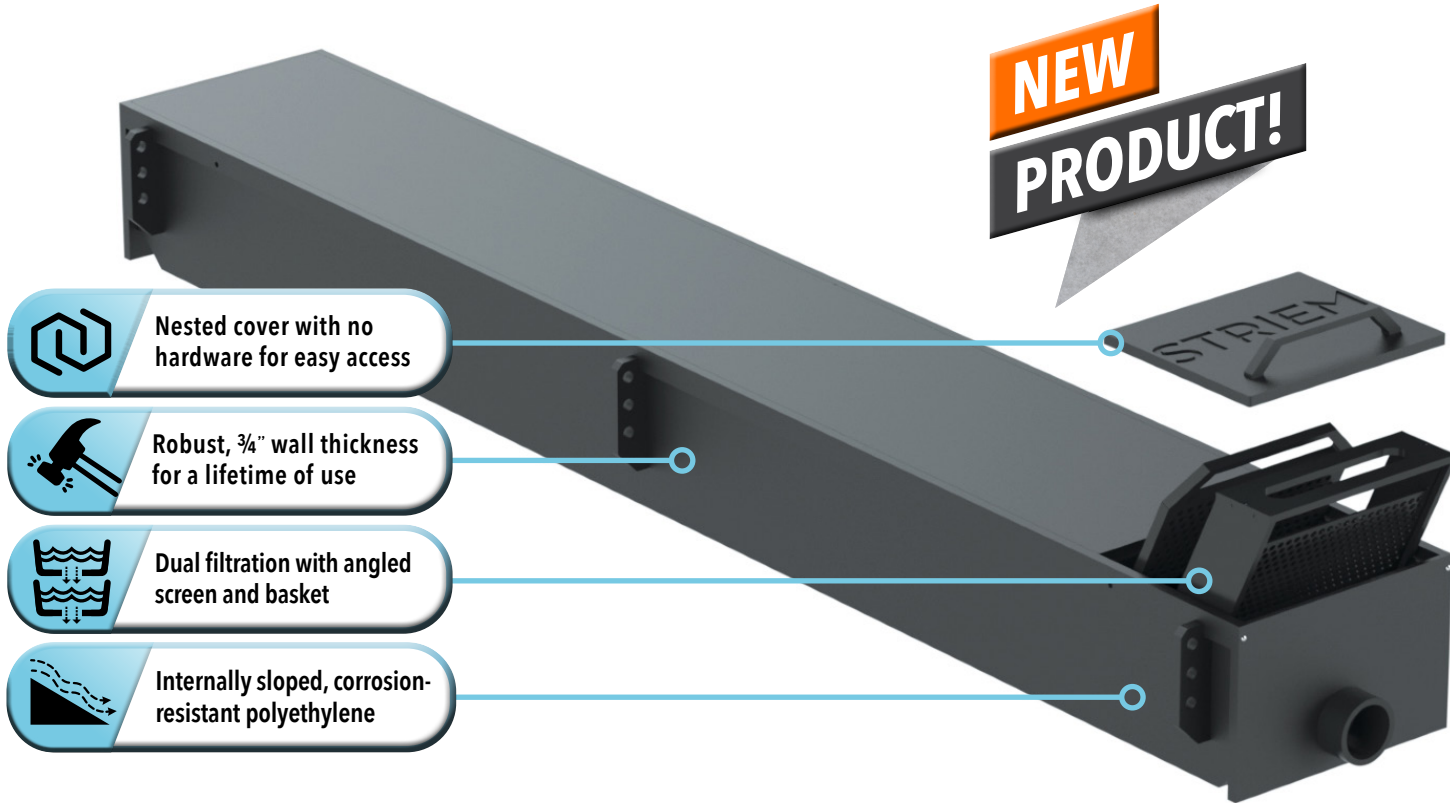

**NEW  
PRODUCT!**

Nested cover with no hardware for easy access

Robust, 3/4" wall thickness for a lifetime of use

Dual filtration with angled screen and basket

Internally sloped, corrosion-resistant polyethylene



Industry's first integrated trough basket filter



Above- and below-grade installation options

**A DRAIN TROUGH SOLVES TWO ISSUES FOR COMMERCIAL LAUNDRIES:**

**FIRST ISSUE: High Discharge Flow Rate from Washer**  
The trough acts as a water and suds reservoir. Washer drainage flow rates are high, and can potentially overwhelm a drainage system. A trough provides more open volume to allow water to drain at its natural pace. It also provides air volume for suds to dissipate.

**SECOND ISSUE: Drainage System Blockage**  
The trough has a solids filter near the outlet to block lint, buttons, hair, and coins (among other items) from entering the drainage system and causing a blockage.

**STANDARD SIZES**

Model	Dimensions (L x W x H)	Liquid Capacity
TT-3	3' x 18" x 12"	21 gal.
TT-4	4' x 18" x 12"	28 gal.
TT-5	5' x 18" x 12"	34 gal.
TT-6	6' x 18" x 12"	41 gal.
TT-8	8' x 18" x 12"	55 gal.
TT-10	10' x 18" x 12"	68 gal.

For custom sizes, please contact Striem.

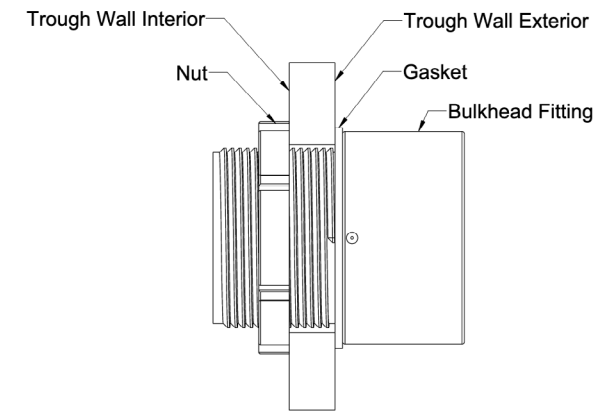

Inlet connections from each washer can be installed in the side or top of the drain trough by the installing contractor. For side connection(s), use Striem's IBK-3 bulkhead fitting kit. This 3" Plain End Inlet Bulkhead Kit (IBK) offers easy watertight inlet installation.

**SIZING**

**DRAIN TROUGH CAPACITIES ARE TYPICALLY SIZED BASED ON A COMBINATION OF TWO FACTORS:**

1. Peak flow demand of upstream washers.
2. Available footprint to install drain trough.

**RECOMMENDED FORMULA FOR SIZING PURPOSES:** **TROUGH VOLUME PER WASHER = (WASHER CAPACITY X 0.8) / 3**

**Example 1:** (1) 65# washer  
 $(65 \times 0.8) / 3 = 17.3$  gal.  
Recommendation: **Striem TT-3**

**Example 2:** (2) 60# washers and (2) 30# washers  
 $(60 \times 0.8) / 3 = 16$  gal. x 2 = 32 gal.  
 $(30 \times 0.8) / 3 = 8$  gal. x 2 = 16 gal.  
Total trough capacity = 48 gal.  
Recommendation: **Striem TT-8**

- Assumptions:
- Water usage factor of 0.8 per lb. of clothing capacity
  - Washer fills and dumps on average three times per cycle

**ON-PREMISE LAUNDRY**



**VENDED LAUNDRY**



**PRODUCT  
UPGRADE**

Field-extendable  
PVC basket handle.

Field adjustable cover  
adapter up to 5".  
Risers available for  
deeper burials.

U-shaped perforated  
basket makes solids  
removal easy.

Robust polyethylene  
tank for above-  
or below-grade  
installation.

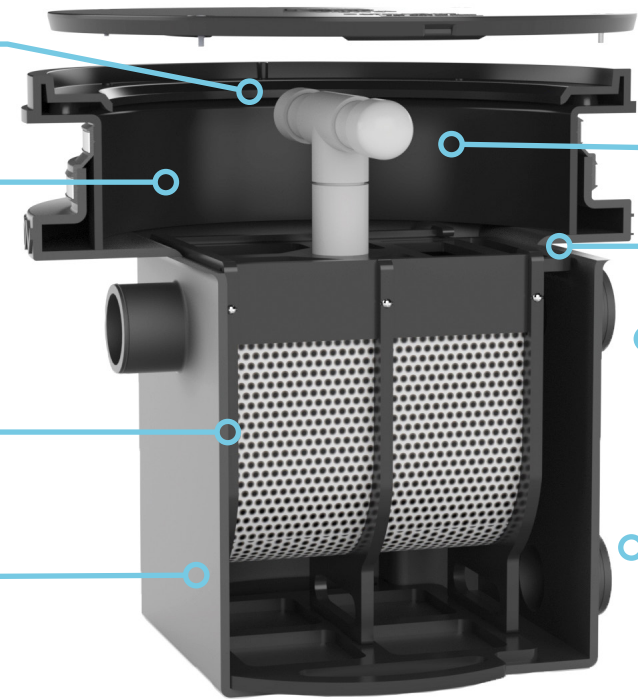

Lid and handle are  
removable to make  
top of basket  
entirely open during  
maintenance.

Molded-in high and  
low outlet option.  
Preferred outlet is cut  
in the field.

(AA-3 shown)

**SAME TANK & BASKET WITH FOUR CONNECTION SIZE OPTIONS:**

AA-2	AA-3	AA-4	AA-6
2" plain end connections	3" plain end connections	4" plain end connections	6" plain end connections
24-1/2"			
23"			

Includes Pedestrian-rated bolted composite cover.

**APPLICATIONS**



ART ROOM  
SINKS



DOG WASH &  
PET KENNELS



BARBER SHOPS &  
HAIR SALONS



COMMERCIAL  
KITCHENS



LAUNDRY  
FACILITIES



UTILITY SINKS

**OPTIONS**

**Covers**



**C24-H**  
Traffic-rated  
bolted composite

Page 30 - product details



**C24-HP**  
H-20 rated  
pickable cast iron

**SR/LR field-adjustable extensions**



**SR-24 / LR-24**

Page 28 - product details

**Anchor Flange**

Integral welded anchor flange at  
base of tank to provide anti-buoyancy  
in high water table installation.

Basket lid and  
extendable PVC handle  
are fully removable for  
basket maintenance.

Basket can only be  
inserted inside unit in  
correct orientation.

Recommended for DIY maintenance.

Recommended for professional pumper maintenance.

Visit our website to view all **SCREEN-STYLE INTERCEPTORS** at [STRIEMCO.COM](http://STRIEMCO.COM).



# SAND INTERCEPTORS

## GRATED COVERS:



**CB-50-G** OPTIONS → 24" HDK

CONNECTIONS: 3", 4"  
LIQUID CAPACITY: 57 GAL.  
COVER: CAST IRON GRATE (H-20)  
SOLIDS CAPACITY: 25 GAL.



**CB-125-G** OPTIONS → 24" HDK

CONNECTIONS: 4", 6"  
LIQUID CAPACITY: 110 GAL.  
COVER: CAST IRON GRATE (H-20)  
SOLIDS CAPACITY: 70 GAL.

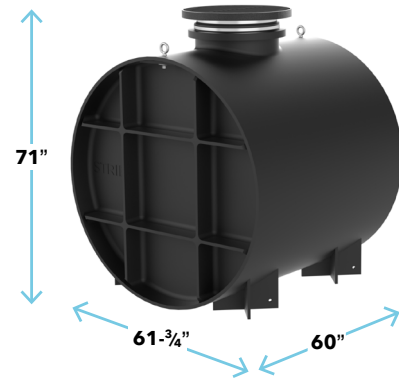

**CB-500-G** OPTIONS → 24" HDK

CONNECTIONS: 4", 6"  
LIQUID CAPACITY: 500 GAL.  
COVER: CAST IRON GRATE (H-20)  
SOLIDS CAPACITY: 400 GAL.

## SOLID COVERS:

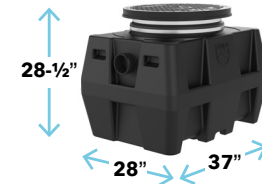

**CB-50-S** OPTIONS → H-20 24" HDK

LIQUID CAPACITY: 57 GAL.  
COVER: TRAFFIC-RATED  
SOLIDS CAPACITY: 25 GAL.



**CB-125-S** OPTIONS → H-20 24" CPRK HDK

LIQUID CAPACITY: 110 GAL.  
COVER: TRAFFIC-RATED  
SOLIDS CAPACITY: 70 GAL.



**CB-275-S** OPTIONS → H-20 24" CPRK HDK

LIQUID CAPACITY: 250 GAL.  
COVER: TRAFFIC-RATED  
SOLIDS CAPACITY: 200 GAL.

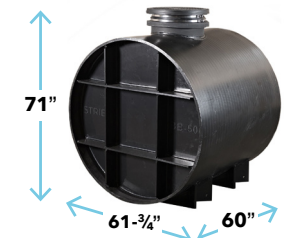

**CB-500-S** OPTIONS → H-20 24" CPRK HDK

LIQUID CAPACITY: 500 GAL.  
COVER: TRAFFIC-RATED  
SOLIDS CAPACITY: 400 GAL.

Visit [STRIEMCO.COM](http://STRIEMCO.COM) for larger tank options.

## BCB-7 Sediment Basket

**G-SERIES  
UPGRADE**



BCB-7 Sediment Basket now standard in all grated-top units.

## APPLICATIONS



SCRUBBER DUMPS



PARKING GARAGES



LOADING DOCKS



MAINTENANCE FACILITIES



CAR WASHES



GREENHOUSES

## OPTIONS

**H-20** C24-HP  
H-20 rated pickable cast iron cover

Page 30 - product details

**CPRK** Corrugated Pipe Riser Kit (CPRK)

Page 28 - product details

SR/LR field-adjustable extensions

**24"** SR-24 / LR-24

Page 28 - product details

**HDK** High water table hold down kits

Page 29 - product details

# CHEMICAL WASTE TANKS



LB-275 with limestone

POINT-OF-USE  
NEUTRALIZATION TANKS

## LAB RAT™ SERIES

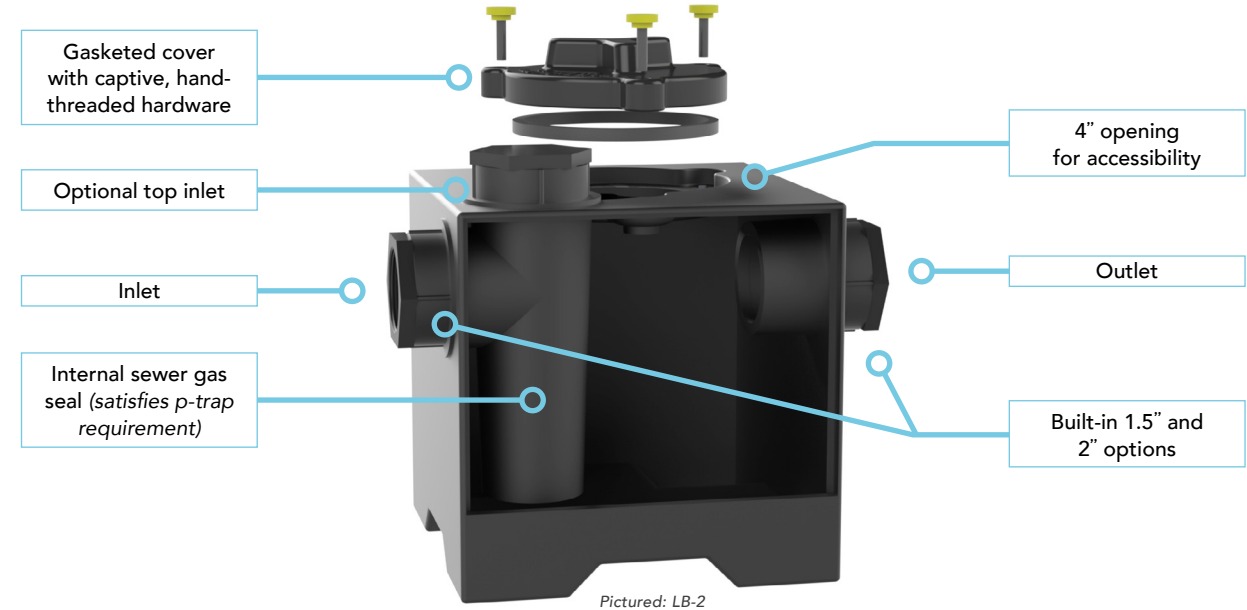

Pictured: LB-2



### LB-2

# OF LAB SINKS: 1  
LIMESTONE LOAD: 25 LBS.  
LIQUID CAPACITY: 2 GAL.

### PRODUCT UPGRADE

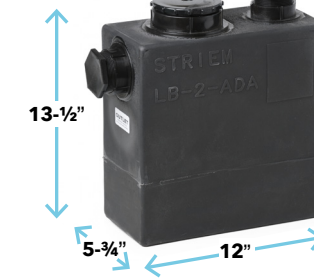

### LB-2-ADA

# OF LAB SINKS: 1  
LIMESTONE LOAD: 25 LBS.  
LIQUID CAPACITY: 2 GAL.

Tank is now rotationally molded.



### LB-5

# OF LAB SINKS: 2  
LIMESTONE LOAD: 50 LBS.  
LIQUID CAPACITY: 5 GAL.



LB-2



Command Center™

## APPLICATION LAYOUTS

### LB-2

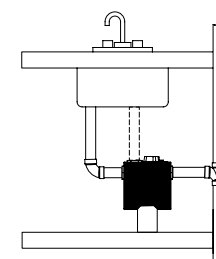

LAB SINK

4" PVC pipe for support cut to size (by others)

### LB-2-ADA

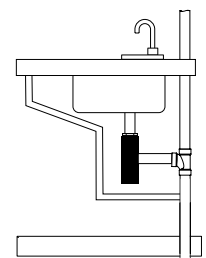

ADA LAB SINK



**LB-15** OPTIONS 16" LS CC-1  
CONNECTIONS: 2", 3" LIMESTONE LOAD: 200 LBS.  
# OF LAB SINKS: 4 COVER: PEDESTRIAN-RATED

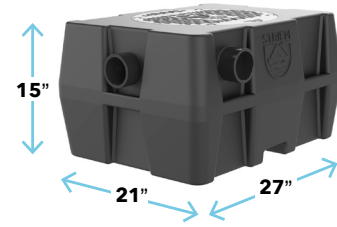

**LB-25** OPTIONS 16" LS CC-1  
CONNECTIONS: 2", 3" LIMESTONE LOAD: 300 LBS.  
# OF LAB SINKS: 6 COVER: PEDESTRIAN-RATED

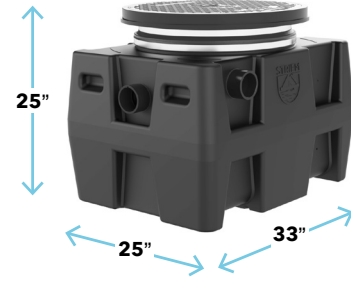

**LB-35** OPTIONS 24" LS CC-1  
CONNECTIONS: 2", 3", 4" LIMESTONE LOAD: 450 LBS.  
# OF LAB SINKS: 9 COVER: PEDESTRIAN-RATED

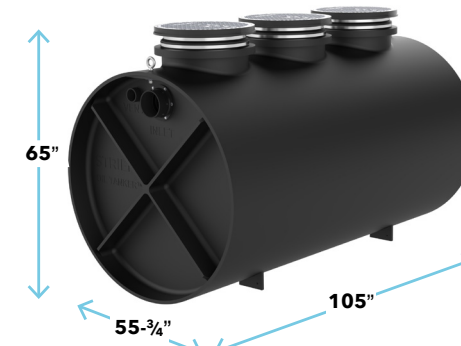

**LB-750** OPTIONS 24" CPRK HDK LS CC-1  
CONNECTIONS: 4", 6", 8" LIMESTONE LOAD: 9,800 LBS.  
# OF LAB SINKS: 215 COVER: TRAFFIC-RATED

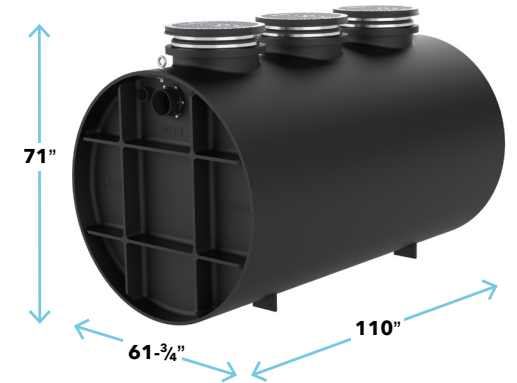

**LB-1000** OPTIONS 24" CPRK HDK LS CC-1  
CONNECTIONS: 4", 6", 8" LIMESTONE LOAD: 13,000 LBS.  
# OF LAB SINKS: 260 COVER: TRAFFIC-RATED



**LB-50** OPTIONS TRAF 24" HDK LS CC-1  
CONNECTIONS: 2", 3", 4" LIMESTONE LOAD: 650 LBS.  
# OF LAB SINKS: 15 COVER: PEDESTRIAN-RATED



**LB-125** OPTIONS 24" CPRK HDK LS CC-1  
CONNECTIONS: 3", 4", 6" LIMESTONE LOAD: 1,550 LBS.  
# OF LAB SINKS: 35 COVER: TRAFFIC-RATED

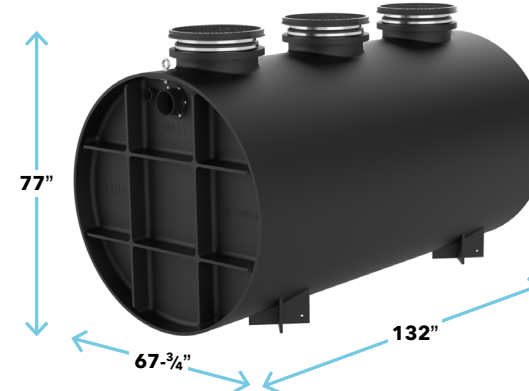

**LB-1500** OPTIONS 24" CPRK HDK LS CC-1  
CONNECTIONS: 4", 6", 8" LIMESTONE LOAD: 19,500 LBS.  
# OF LAB SINKS: 375 COVER: TRAFFIC-RATED

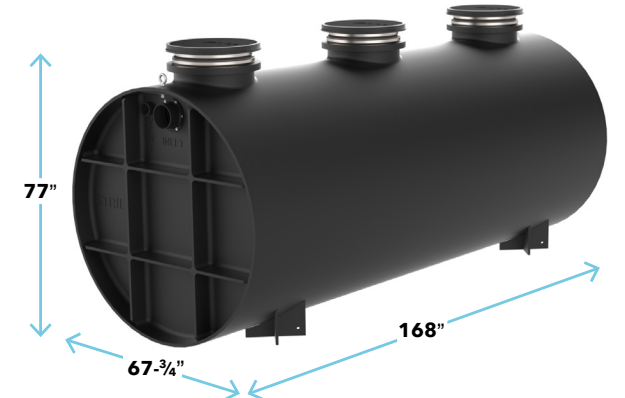

**LB-2000** OPTIONS 24" CPRK HDK LS CC-1  
CONNECTIONS: 4", 6", 8" LIMESTONE LOAD: 25,500 LBS.  
# OF LAB SINKS: 500 COVER: TRAFFIC-RATED



**LB-275** OPTIONS 24" CPRK HDK LS CC-1  
CONNECTIONS: 3", 4", 6" LIMESTONE LOAD: 3,150 LBS.  
# OF LAB SINKS: 75 COVER: TRAFFIC-RATED

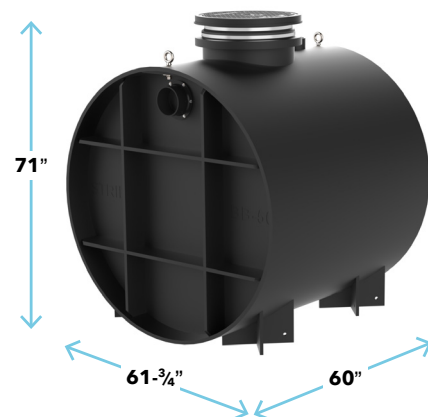

**LB-500** OPTIONS 24" CPRK HDK LS CC-1  
CONNECTIONS: 4", 6", 8" LIMESTONE LOAD: 6,500 LBS.  
# OF LAB SINKS: 150 COVER: TRAFFIC-RATED

## OPTIONS

**TRAF** C24-H  
Traffic-rated bolted composite cover

Page 30 - product details

**CPRK** Corrugated Pipe Riser Kit (CPRK)

Page 28 - product details

**LS** Limestone

Page 30 - product details

### SR/LR field-adjustable extensions

16"

SR-16

Page 28 - product details

24"

SR-24 / LR-24

**HDK** High water table hold down kits

Page 29 - product details

**CC-1** Command Center  
pH Monitoring System

Page 25 - product details

CC-1

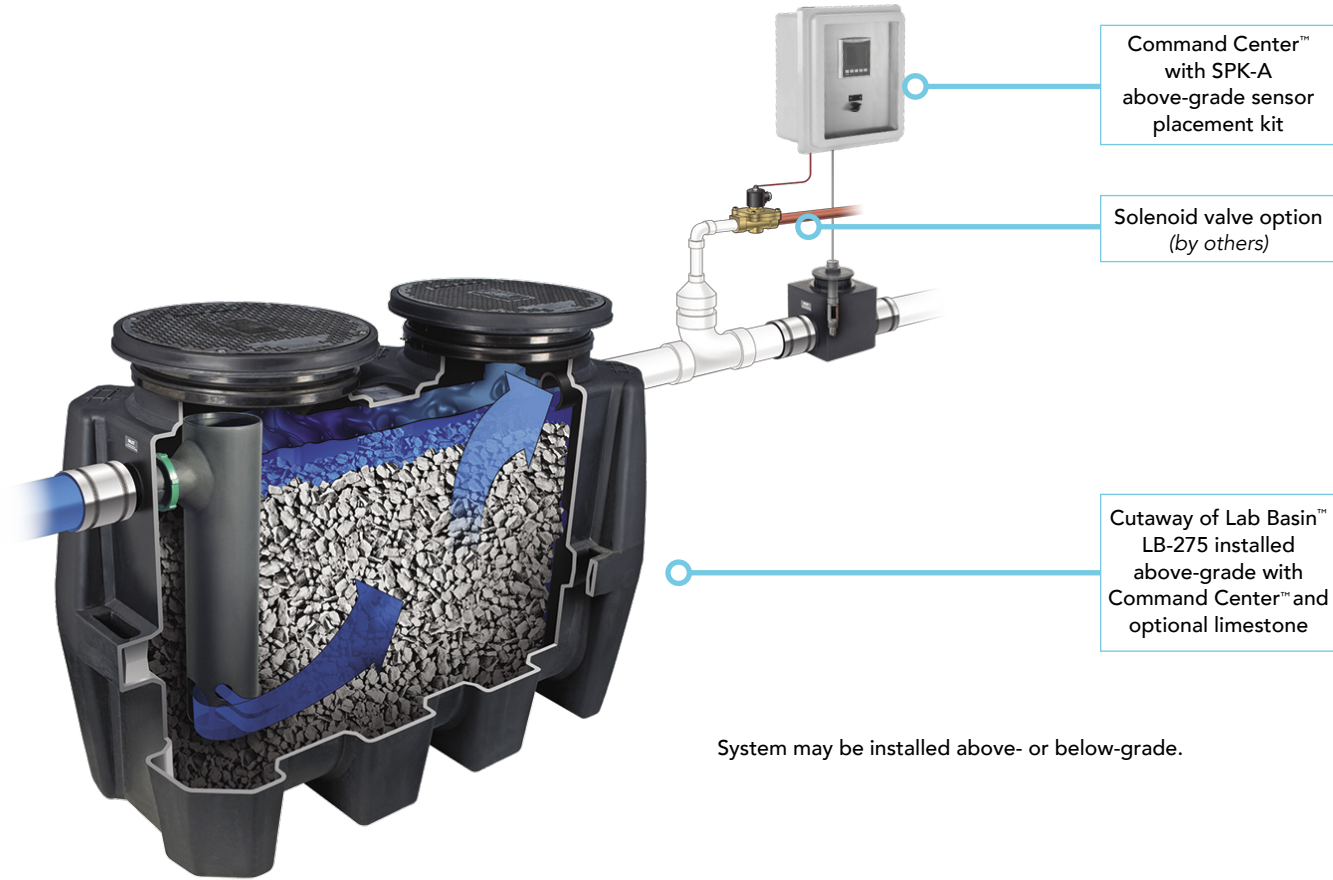

Clear front panel



Touchscreen interface

## SPECIFICATIONS

BMS Capability via ethernet connection	Storage: Includes (2), 1-year micro SD cards
Pre-programmed audio/visual alarm set points	Nema 4x lockable weather proof enclosure -32°F to 122°F
3.5" color touchscreen display	120V AC power supply required
Pre-programmed digital output to power solenoid valve for fresh water to flush if pH approaches high/low limits	

<p><b>BB-275</b>                  OPTIONS: 24" CPRK HDK                  CONNECTIONS: 2", 3", 4", 6"                  LIQUID CAPACITY: 250 GAL.                  COVER: TRAFFIC-RATED</p>	<p><b>BB-500</b>                  OPTIONS: 24" CPRK HDK                  CONNECTIONS: 3", 4", 6"                  LIQUID CAPACITY: 500 GAL.                  COVER: TRAFFIC-RATED</p>
<p><b>BB-750</b>                  OPTIONS: 24" CPRK HDK                  CONNECTIONS: 3", 4", 6"                  LIQUID CAPACITY: 750 GAL.                  COVER: TRAFFIC-RATED</p>	<p><b>BB-1000</b>                  OPTIONS: 24" CPRK HDK                  CONNECTIONS: 3", 4", 6"                  LIQUID CAPACITY: 1,000 GAL.                  COVER: TRAFFIC-RATED</p>
<p><b>BB-1500</b>                  OPTIONS: 24" CPRK HDK                  CONNECTIONS: 3", 4", 6"                  LIQUID CAPACITY: 1,500 GAL.                  COVER: TRAFFIC-RATED</p>	<p><b>BB-2000</b>                  OPTIONS: 24" CPRK HDK                  CONNECTIONS: 3", 4", 6"                  LIQUID CAPACITY: 2,000 GAL.                  COVER: TRAFFIC-RATED</p>

## MONITORING PACKAGES:

<p><b>AVA-3</b> Single-level</p>	<p><b>AVA-4</b> Multi-level</p>
--------------------------------------	-------------------------------------

## OPTIONS

<p><b>SR/LR field-adjustable extensions</b></p> <p>24" SR-24 / LR-24</p> <p>Page 28 - product details</p>	<p><b>CPRK</b> Corrugated Pipe Riser Kit (CPRK)</p> <p>Page 28 - product details</p>	<p><b>HDK</b> High water table hold down kits</p> <p>Page 29 - product details</p>
---	--	--

## SIZING

Striem recommends these steps for sizing a decontamination tank:

$$\left[ \begin{array}{c} \text{Number} \\ \text{of Fixtures} \\ \text{(showers or} \\ \text{eyewash stations)} \end{array} \right] \times \left[ \begin{array}{c} \text{Supply Line} \\ \text{Flow Rate of} \\ \text{Each Fixture} \end{array} \right] \times \left[ \begin{array}{c} \text{Rinse Time} \\ \text{(15-20 minutes} \\ \text{typical)} \end{array} \right] = \text{SIZE OF TANK IN GALLONS}$$

Sizing Sample:

1. A hospital with two emergency showers, each with a 3/4" supply line carrying a flow rate of 9.96 GPM. 2 fixtures x 9.96 GPM = 19.92 GPM
2. 19.92 GPM x 15 minutes = 298.8 gallons
3. Select Bio Basin™ model BB-500 (500 liquid holding gallons)

Visit our website for **LOW OUTLET VALVE PACKAGES** — See product specifications at [STRIEMCO.COM](http://STRIEMCO.COM).



WATCH VIDEO



AVAILABLE ONLINE FOR ALL PRODUCTS

**INSPECTOR-4**

4" connections



**INSPECTOR-6**

6" connections



**SPECIFICATIONS**

Unit supplied with built-in adapter for up to 5" adjustability	Lightweight and easy to install
Additional riser(s) available for deeper burial depth	Maximum operating temperature 140° F
Polyethylene construction	Highway rated (16,000 lb. load) bolted, gas/water tight composite cover. (H-20 cast iron available)

**SR-16**

For use with tanks with 16" cover



**SR-24**

**SHORT RISER**  
For use with tanks with 24" cover



**LR-24**

**LONG RISER**  
For use with tanks with 24" cover



SR-24 and LR-24 risers are stackable.

Tilt adapter up to 6.5° in all directions to match grade.



**CPRK Corrugated Pipe Riser Kit**

Uses 18" Inner Diameter ADS N-12 Dual Wall HDPE Pipe (by others)



WATCH VIDEO



Cost-effective option for deeper burials and/or on tanks with multiple manways.

CPRK

# HIGH WATER TABLE HOLD DOWN KITS

HDK

## HDK-2



**Compatible with:**

- OS-50, OS-75, OS-100
- PS-50-S, PS-125-S, PS-275-S
- CB-50-S, CB-125-S, CB-275-S, CB-50-G, CB-125-G
- LB-50, LB-125, LB-275
- BB-275

## HDK-3



**Compatible with:**

- OT-500

## HDK-4



**Compatible with:**

- OT-750
- CB-750-S
- LB-750
- BB-750

## HDK-5



**Compatible with:**

- OT-1000
- CB-1000-S
- LB-1000
- BB-1000

## HDK-6



**Compatible with:**

- OT-1500
- CB-1500-S
- LB-1500
- BB-1500

## HDK-7



**Compatible with:**

- OT-2000
- CB-2000-S
- LB-2000
- BB-2000

## HDK-8



**Compatible with:**

- CB-500-G
- CB-500-S
- LB-500
- BB-500
- CB-500-G

# COVERS

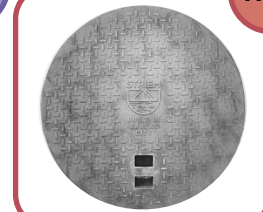

	C16-M	C24-M	C24-H	C24-HP
LOCATION:	INDOOR	INDOOR	INDOOR / OUTDOOR	OUTDOOR
DIAMETER:	16"	24"	24"	24"
TYPE:	BOLTED POLYPROPYLENE	BOLTED COMPOSITE	BOLTED COMPOSITE	PICKABLE CAST IRON
LOAD RATING:	2,500 LBS.	2,000 LBS.	16,000 LBS.	16,000 LBS. H-20 RATED

# LIMESTONE

LS



- 90% or greater calcium carbonate content
- 1" - 3" in size
- 25 lbs. and 50 lbs. options available

# COALESCING MEDIA

CS



When oily wastewater is mechanically emulsified (as in pump applications), oils break into smaller, less buoyant droplets and decrease separator efficiency. Coalescing media provides increased surface area for emulsified oil droplets to merge into larger, more buoyant droplets, greatly improving separator efficiency. Specify Clean Sweep™ coalescing media with select OS Series models (OS-35, OS-50, OS-75, OS-100) and all OT Series models (OT-500, OT-750, OT-1000, OT-1500, OT-2000) to significantly improve the separation of mechanically emulsified oils. Clean Sweep™ coalescing media has been third party tested to standard CEN EN858-1.





 **913-222-1500**

 **HELP@STRIEMCO.COM**

 **STRIEMCO.COM**

*Manufacturing in Kansas City, KS*