

SPECIFICATIONS

- 6" Plain End inlet/outlet shown, 3" Plain End vents standard.
- Liquid capacity: 2000 Gallons (267 cu. ft.).
- Flammable liquid capacity: 638 Gallons.
- Solids capacity: 1077 Gallons.
- Unit weight w/ standard covers: 1824 lbs.; w/ cast iron covers: 2004 lbs.
- Maximum operating temperature 140°F continuous.

NOTES

- For gravity drainage applications only.
- Do not use for pressure applications.
- Cover placement allows full access to tank for proper maintenance.
- Lifting lug set for easy install.

ENGINEER SPECIFICATION GUIDE

Striem flammable liquid interceptor model FLI-2000 shall be lifetime guaranteed and made in the USA. Interceptor shall be constructed of polyethylene with 7/8" nominal wall thickness. Interceptor shall be manufactured for below-grade installation. Field-adjustable riser system is available as an option to bring manhole covers to grade. Interceptor liquid holding capacity shall be 2000 gallons and flammable liquid capacity shall be 638 gallons. Solids capacity shall be 1077 gallons. Covers shall provide water/gas-tight seal and have a maximum 16,000 lbs. load capacity.

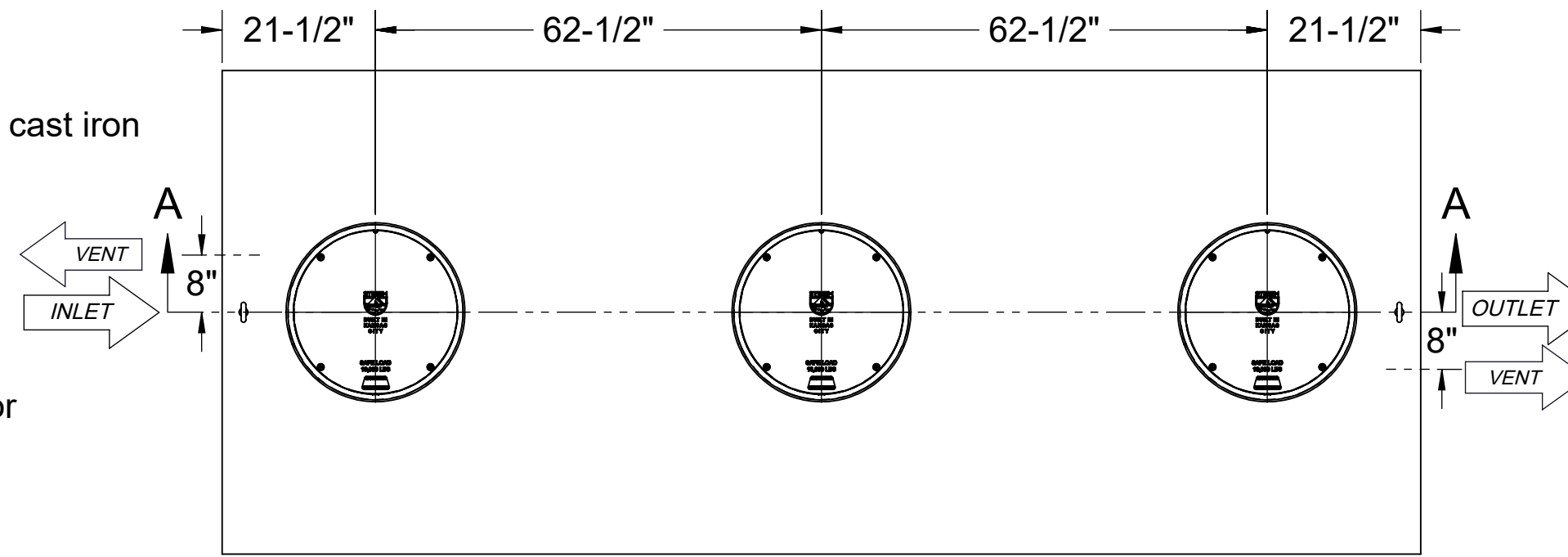

TOP VIEW

OPTIONS

Connection Options (Plain End Only)

Size

- 4"
- 6"
- 8"

SELECTION REQUIRED

Riser Options

From Factory: Up to 5"

- Up to 24": **SR24** (3)
- Up to 39": **LR24** (3)
- Up to 43": **SR24** (6)
- Up to 58": **SR24** (3) + **LR24** (3)
- Up to 72": **LR24** (6)
- Up to 90": **SR24** (3) + **LR24** (6)
- Up to 106": **LR24** (9)

- OR -

- CPRK** (3): 11" - 106" (See specification for more detail.)

Additional Options

- HDK-7**: High Water Table Hold Down Kit
- C24-HP** (3): H2O Rated Pickable Cast Iron Covers
- SS**: Slick Stick™ Oil Level Monitoring System*

*Monitoring system will raise covers by 3".

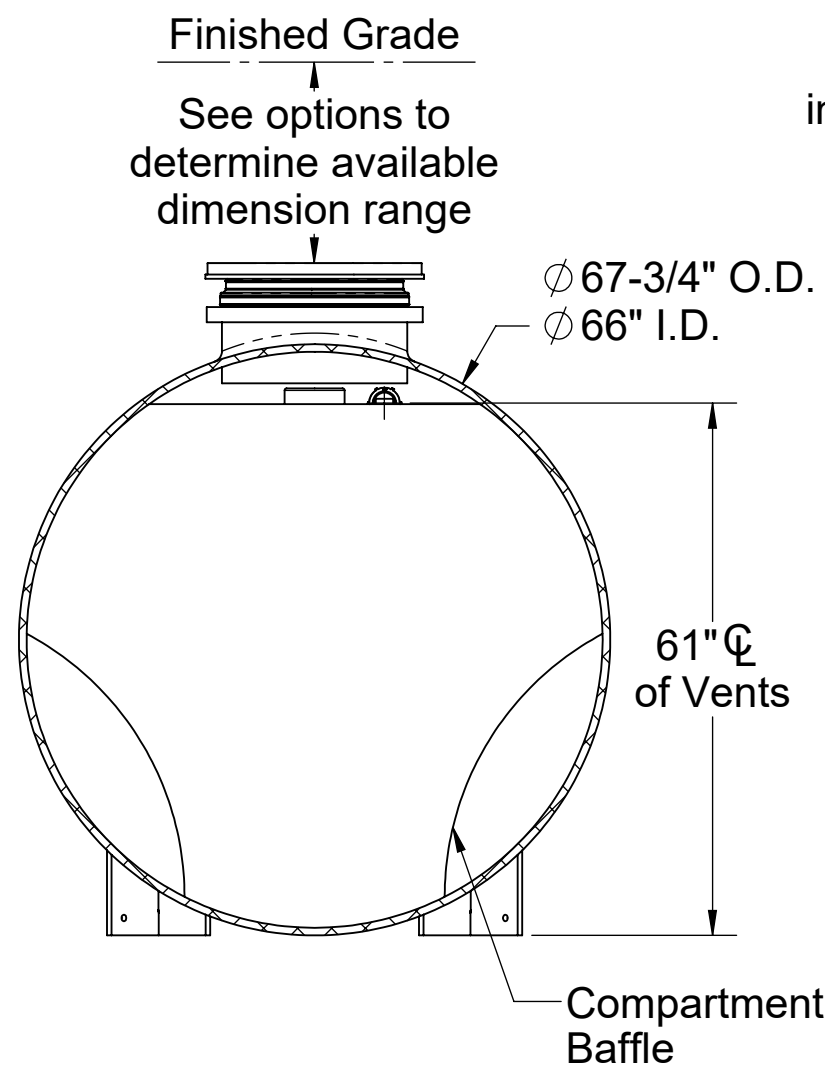

SECTION B-B

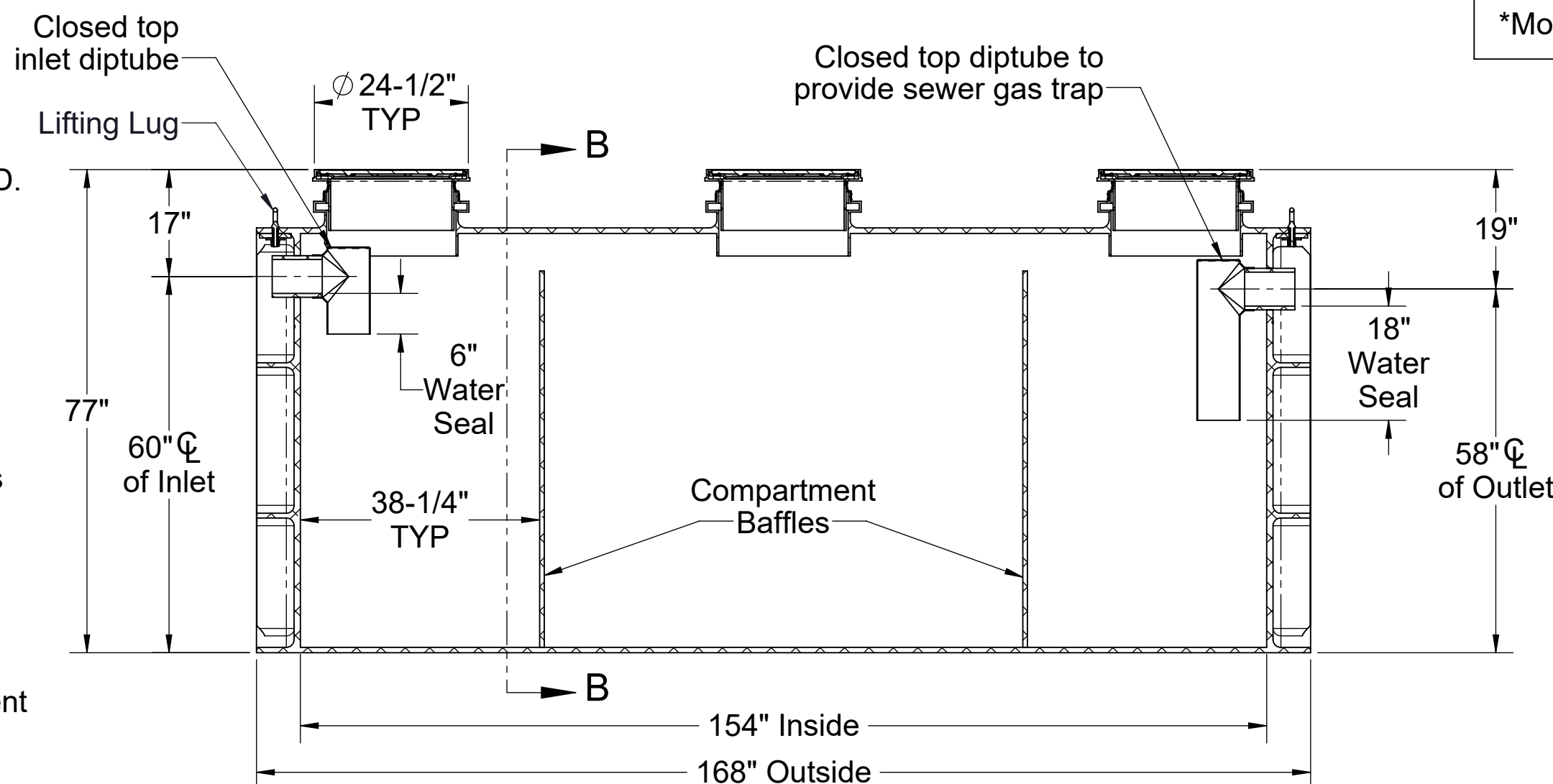

SECTION A-A

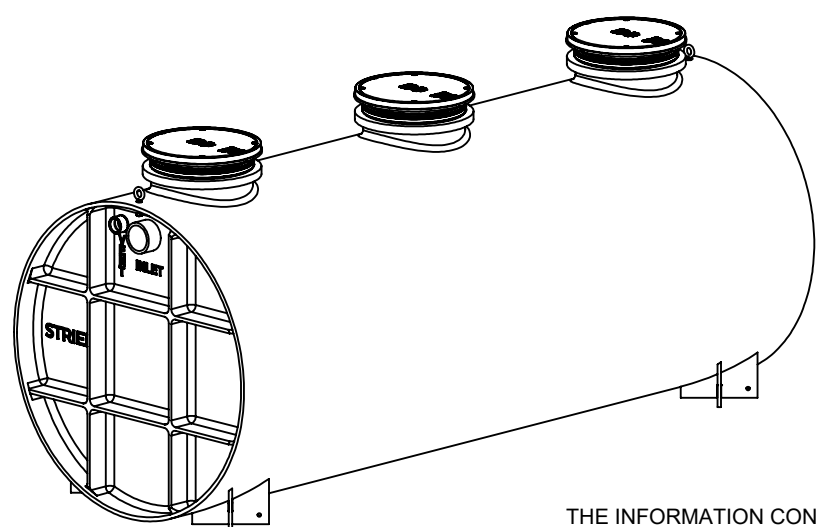

PO IS NON-CANCELABLE ORDER IS NON-RETURNABLE

PROPRIETARY AND CONFIDENTIAL
THE INFORMATION CONTAINED IN THIS DRAWING IS THE SOLE PROPERTY OF STRIEM, LLC. ANY REPRODUCTION IN PART OR AS A WHOLE WITHOUT THE WRITTEN PERMISSION OF STRIEM, LLC. IS PROHIBITED.

MODEL NUMBER: FLI-2000

DESCRIPTION:
POLYETHYLENE
FLAMMABLE LIQUID INTERCEPTOR
2000 GALLON CAPACITY
UNRATED

DWG BY: ENG **DATE:** 8/22/2023 **REV:** 1

SPECIFICATION SHEET

Striem
Kansas City, KS
Tel: 913-222-1500
orders@striemco.com
www.striemco.com

Made in the U.S.A

