

SPECIFICATIONS

1. 2" Plain End inlet, 3" Plain End vents, C24-M cover standard.
2. Oil capacity: 57 Gallons (7.6 cu ft).
3. Unit weight w/ standard cover: 93 lbs.; w/ cast iron cover: 153 lbs.
4. Maximum operating temperature: 140°F continuous.

NOTES

1. For gravity drainage applications only.
2. Do not use for pressure applications.
3. Narrow footprint allows clearance through doorways and down stairs.
4. Cover placement allows full access to tank for proper maintenance.

ENGINEER SPECIFICATION GUIDE

Striem oil collection tank model OCT-50 shall be lifetime guaranteed and made in the USA. Tank shall be constructed of polyethylene. Tank shall be manufactured for above- or below-grade installation. Field-adjustable riser system is available as an option to bring manhole cover to grade. Tank oil collection capacity shall be 57 gallons. Cover shall provide water/gas-tight seal and have a maximum 2,000 lbs. load capacity.

THIRD PARTY STRUCTURAL ANALYSIS

The OCT-50 has been structurally analyzed in accordance with the requirements of IBC 2012 and ASCE/SEI 7 for direct burial. The maximum burial depth and backfill material are specified in our installation instructions. The structural design has been reviewed and sealed by a professional engineer registered in the state of California. A sealed structural analysis report is available upon request.

OPTIONS

Connection Options (Plain End Only)

- Inlet**
- 2"
 - 3"
 - 4"

Riser Options

- From Factory:** Up to 5" (Up to 2" w/ monitoring)
- Up to 24" (21" w/ monitoring): **SR24**
 - Up to 39" (36" w/ monitoring): **LR24**

Additional Options

- HDK-2:** High Water Table Hold Down Kit
- C24-H:** Highway Rated Composite Cover
- C24-HP:** H20 Rated Pickable Cast Iron Cover
- AVA-3:** Single-Level Monitoring Package
- AVA-4:** Multi-Level Monitoring Package

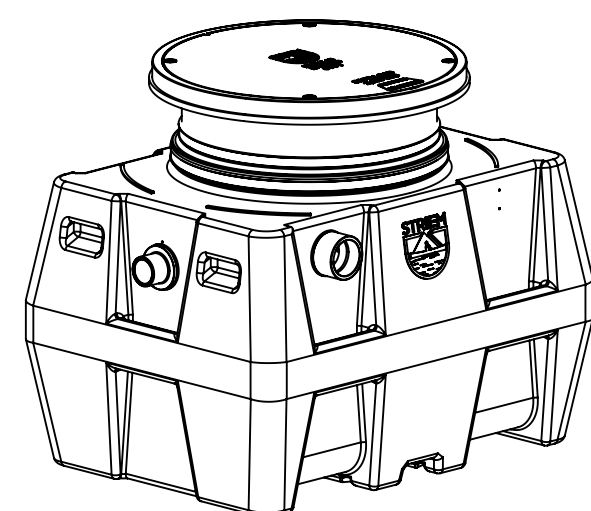
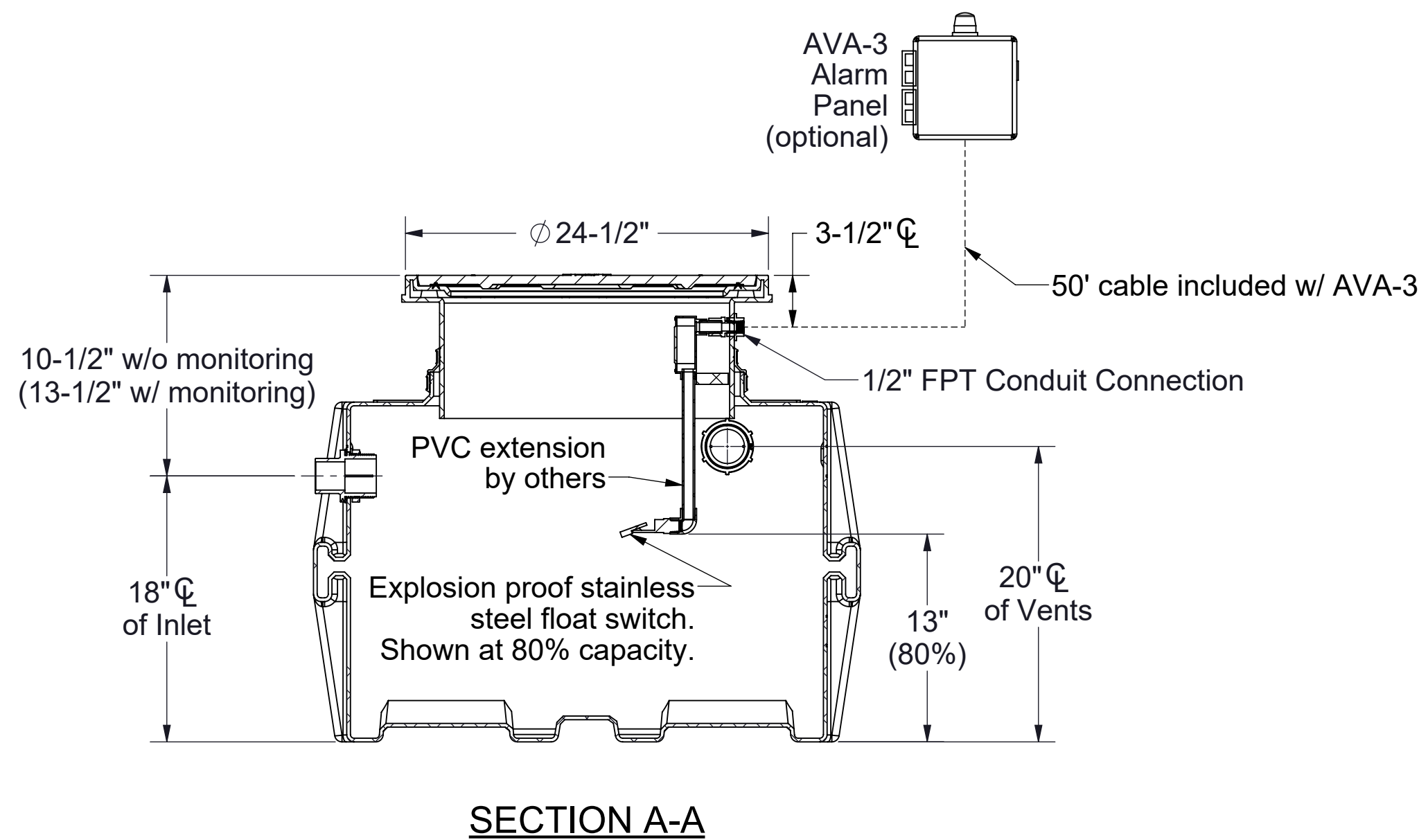
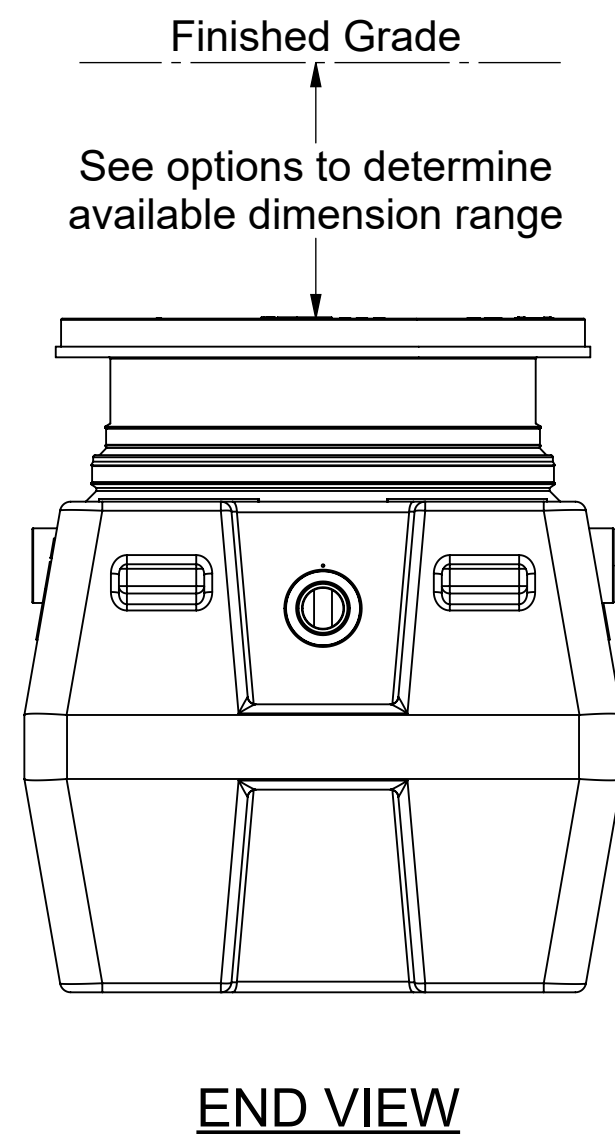
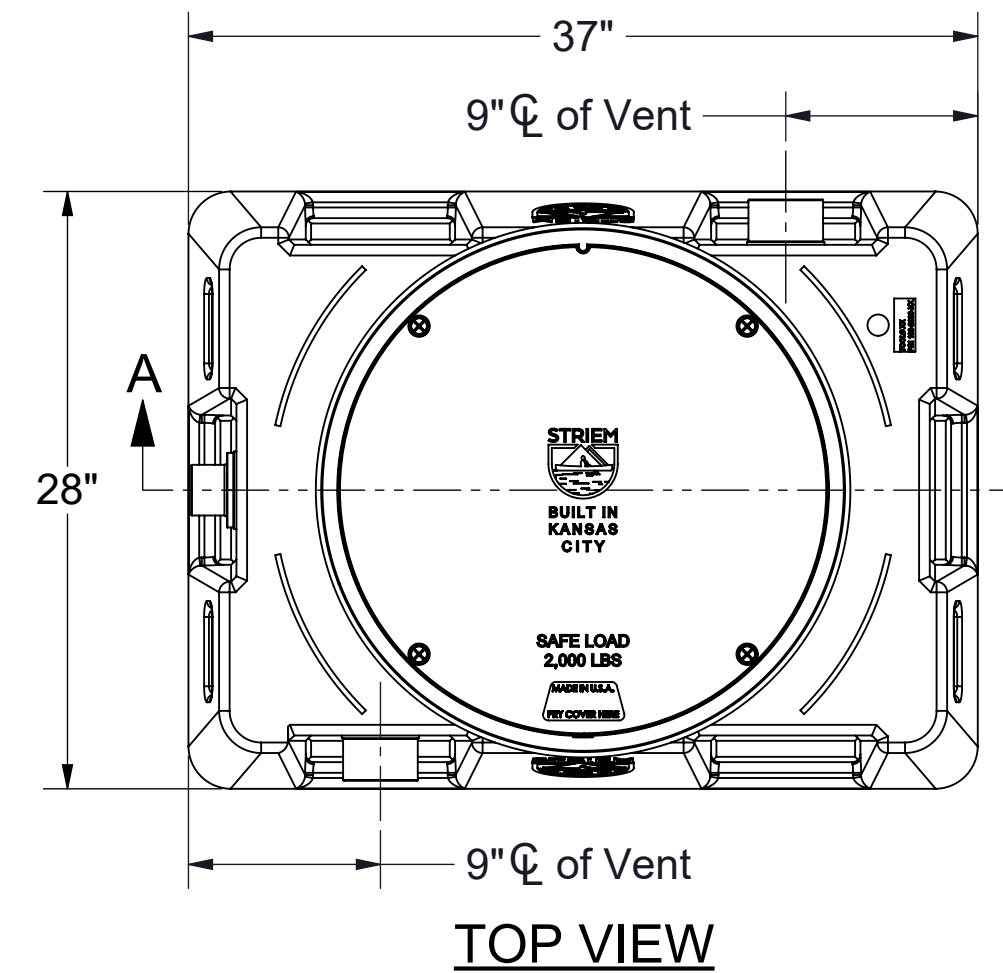

PROPRIETARY AND CONFIDENTIAL
 THE INFORMATION CONTAINED IN THIS DRAWING IS THE SOLE PROPERTY OF STRIEM, LLC.
 ANY REPRODUCTION IN PART OR AS A WHOLE WITHOUT THE WRITTEN PERMISSION OF STRIEM, LLC. IS PROHIBITED.

MODEL NUMBER:	OCT-50
DESCRIPTION:	57 GALLON POLYETHYLENE OIL COLLECTION TANK
DWG BY:	ENG
DATE:	1/12/2024
REV:	1

SPECIFICATION SHEET

Striem
 Kansas City, KS
 Tel: 913-222-1500
 orders@striemco.com
 www.striemco.com

Made in the U.S.A