

**SPECIFICATIONS**

1. 3" Plain End inlet/outlet, 3" Plain End vents standard.
2. Certified max flow rate: 25 GPM.
3. Liquid capacity: 21 Gallons (2.8 cu. ft.).
4. Oil capacity: 5.25 Gallons.
5. Solids capacity: 6 Gallons.
6. Unit weight: 33 lbs.
7. Maximum operating temperature 140°F continuous.

**NOTES**

1. Engineered inlet diffuser efficiently separates oil from water.
2. For gravity drainage applications only.
3. Do not use for pressure applications.
4. Cover placement allows full access to tank for proper maintenance.

**ENGINEER SPECIFICATION GUIDE**

Striem high efficiency oil/water separator model OS-25 shall be lifetime guaranteed and made in the USA. Separator shall be certified to IAPMO IGC 325 and carry a UPC listing. Separator shall be constructed of polyethylene. Separator shall be manufactured for above- or below-grade installation. Field-adjustable riser system is available as an option to bring manhole cover to grade. Separator flow rate shall be 25 GPM. Separator liquid holding capacity shall be 21 gallons and oil capacity shall be 5.25 gallons. Solids capacity shall be 6 gallons. Cover shall provide water/gas-tight seal and have a maximum 450 lbs. load capacity when unit is installed above-grade, and 2,500 lbs. when buried with SR16 riser.

**IAPMO IGC 325 CERTIFICATION**

The OS-25 has been third party certified by IAPMO to the IGC 325 standard. The OS-25 achieved an average 99% efficiency rating at 25 GPM up to the maximum oil capacity of 5.25 gallons. The structural design has been approved and stamped by a licensed structural engineer for direct burial in accordance with Striem's installation instructions.

**OPTIONS**

**SR16 Riser:** 4"-16" Burial Range

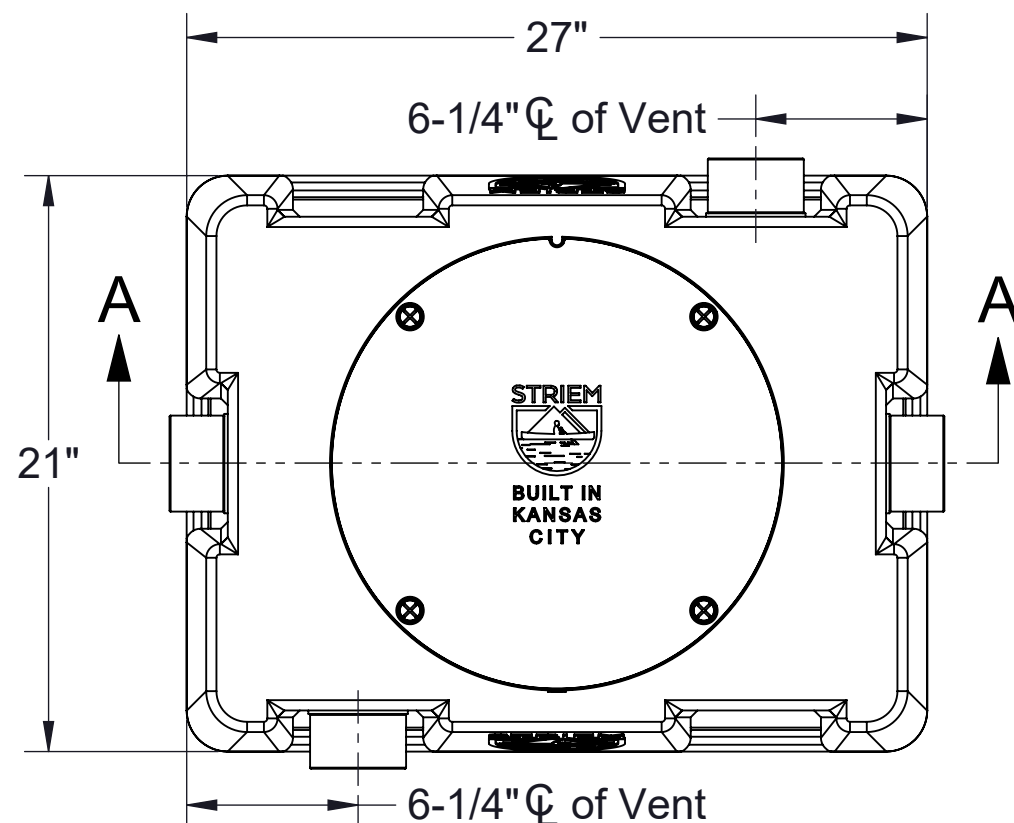

**TOP VIEW**

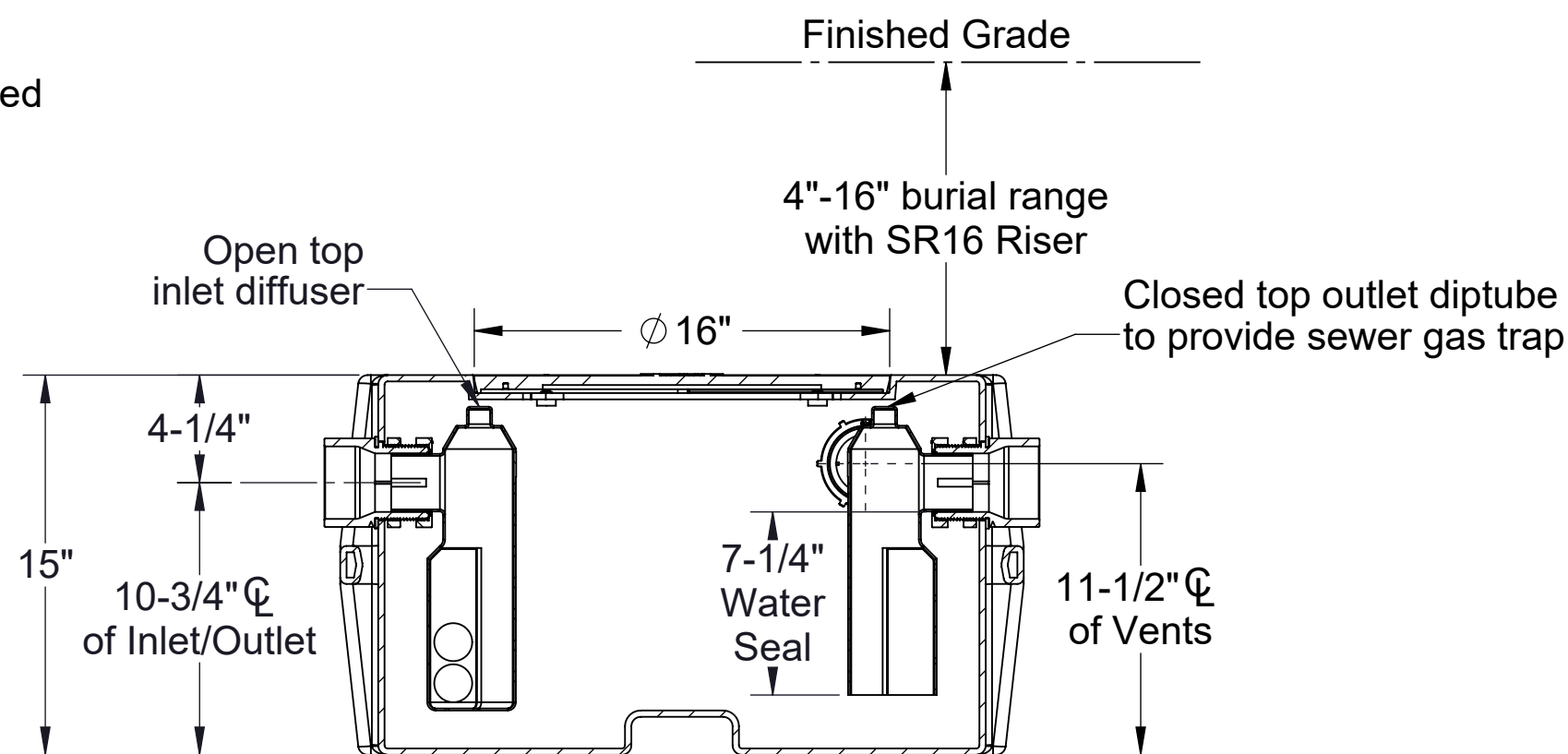

**SECTION A-A**

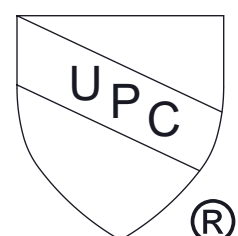
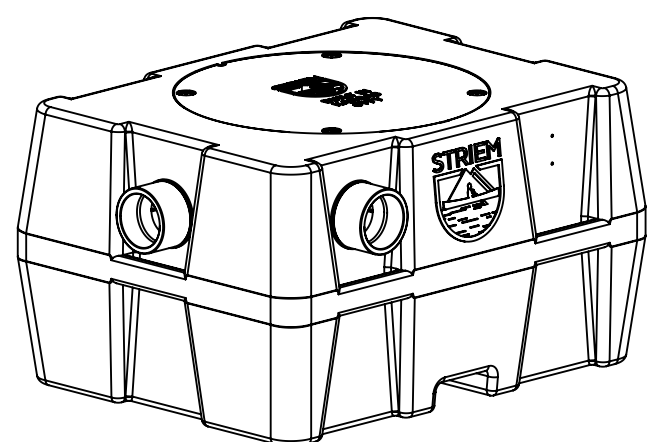

**PROPRIETARY AND CONFIDENTIAL**  
THE INFORMATION CONTAINED IN THIS DRAWING IS THE SOLE PROPERTY OF STRIEM, LLC. ANY REPRODUCTION IN PART OR AS A WHOLE WITHOUT THE WRITTEN PERMISSION OF STRIEM, LLC. IS PROHIBITED.

<b>MODEL NUMBER:</b>	OS-25
<b>DESCRIPTION:</b>	25 GPM POLYETHYLENE HIGH EFFICIENCY OIL/WATER SEPARATOR
<b>DWG BY:</b>	ENG
<b>DATE:</b>	12/13/2023
<b>REV:</b>	2

**SPECIFICATION SHEET**

Striem  
Kansas City, KS  
Tel: 913-222-1500  
orders@striemco.com  
www.striemco.com

Made in the U.S.A

