

**SPECIFICATIONS**

1. 6" Plain End inlet/outlet shown, 3" Plain End vents standard.
2. Max flow rate: 314 GPM.
3. Liquid capacity: 2000 Gallons (267 cu. ft.).
4. Oil capacity: 638 Gallons.
5. Solids capacity: 1077 Gallons.
6. Unit weight: 2000 lbs.
7. Maximum operating temperature 140°F continuous.

**NOTES**

1. For gravity drainage applications only.
2. Do not use for pressure applications.
3. Cover placement allows full access to tank for proper maintenance.
4. Lifting lug set for easy install.

**ENGINEER SPECIFICATION GUIDE**

Striem oil separator model OT-2000 shall be lifetime guaranteed and made in the USA. Separator shall be constructed of polyethylene with 7/8" nominal wall thickness. Separator shall be manufactured for below-grade installation. Field-adjustable riser system is available as an option to bring manhole covers to grade. Separator flow rate shall be 314 GPM. Separator liquid holding capacity shall be 2000 gallons and oil capacity shall be 638 gallons. Solids capacity shall be 1077 gallons. Covers shall be H20 rated pickable cast iron. Separator shall be certified to IAPMO IGC 183-2016 and carry a UPC listing.

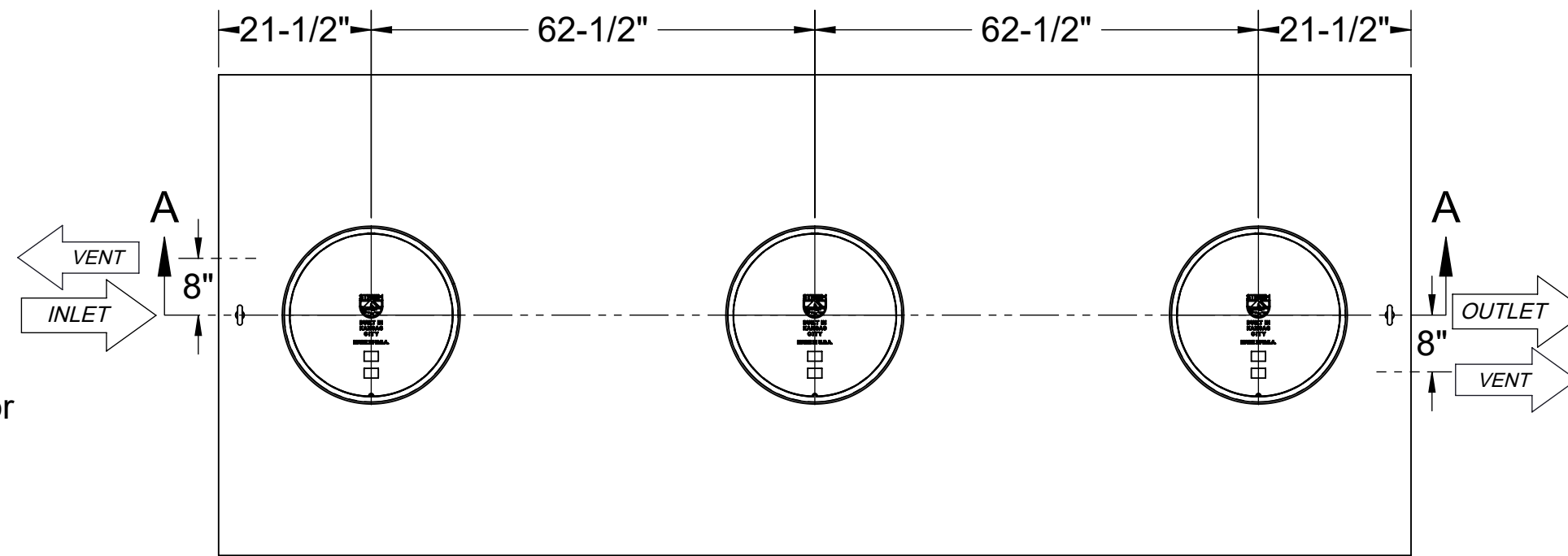

**TOP VIEW**

**OPTIONS**

**Connection Options (Plain End Only)**

**Inlet / Outlet**

- 4"
- 6"
- 8"

SELECTION REQUIRED

**Riser Options**

**From Factory: Up to 5"**

- Up to 24": **SR24** (3)
- Up to 39": **LR24** (3)
- Up to 43": **SR24** (6)
- Up to 58": **SR24** (3) + **LR24** (3)
- Up to 72": **LR24** (6)
- Up to 90": **SR24** (3) + **LR24** (6)
- Up to 106": **LR24** (9)

- OR -

- CPRK** (3): 11" - 106" (See specification for more detail.)

**Additional Options**

- HDK-7**: High Water Table Hold Down Kit
- SS**: Slick Stick™ Oil Level Monitoring System\*

\*Monitoring system will raise covers by 3".

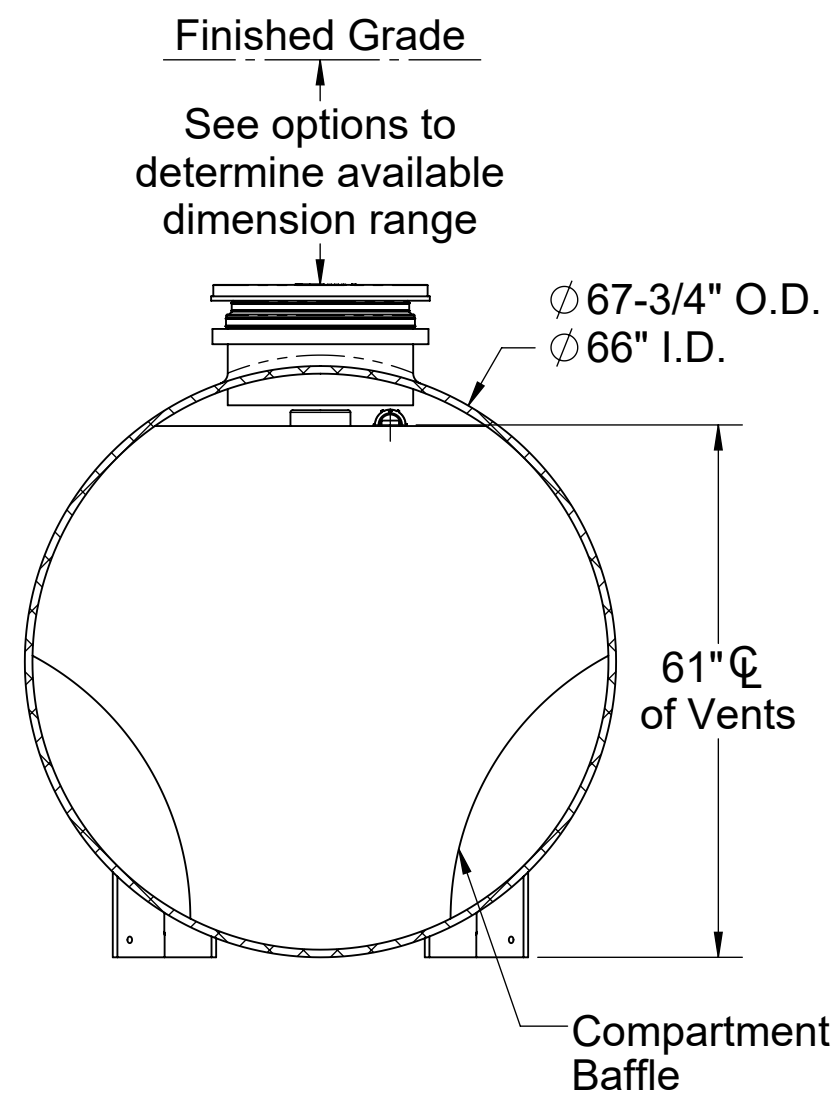

**SECTION B-B**

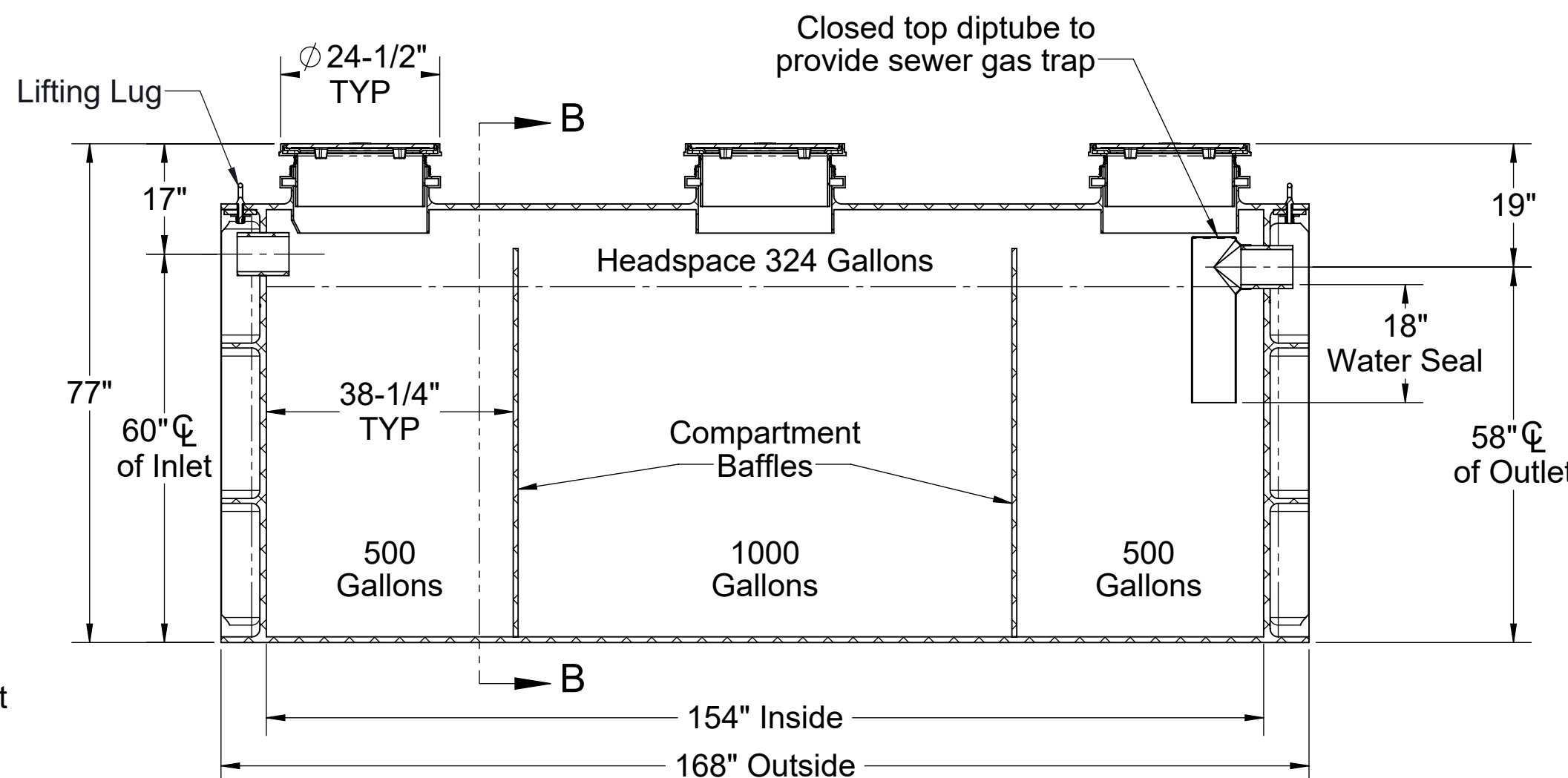

**SECTION A-A**

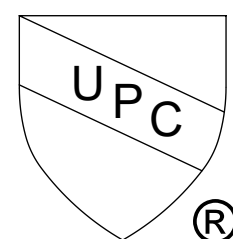
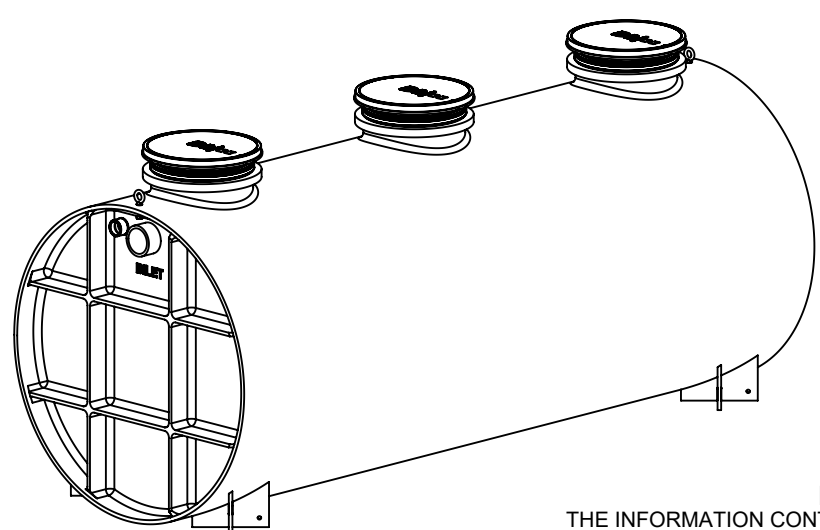

PO IS NON-CANCELABLE  
ORDER IS NON-RETURNABLE

PROPRIETARY AND CONFIDENTIAL  
THE INFORMATION CONTAINED IN THIS DRAWING IS THE SOLE PROPERTY OF STRIEM, LLC.  
ANY REPRODUCTION IN PART OR AS A WHOLE WITHOUT THE WRITTEN PERMISSION OF STRIEM, LLC, IS PROHIBITED.

**MODEL NUMBER:** OT-2000

**DESCRIPTION:**  
OIL TANKER™  
POLYETHYLENE OIL SEPARATOR  
2000 GALLON CAPACITY

**DWG BY:** ENG    **DATE:** 1/10/2024    **REV:** 1

**SPECIFICATION SHEET**

Striem  
Kansas City, KS  
Tel: 913-222-1500  
orders@striemco.com  
www.striemco.com

Made in the U.S.A

