

**SPECIFICATIONS**

1. 4" Plain End inlet/outlet, C24-H covers standard.
2. Max flow rate: 100 GPM.
3. Liquid capacity: 250 Gallons.
4. Solids capacity: 210 Gallons.
5. Unit weight w/ standard covers: 260 lbs.; w/ cast iron covers: 380 lbs.
6. Maximum operating temperature 140 °F continuous.

**NOTES**

1. For gravity drainage applications only.
2. Do not use for pressure applications.
3. Cover placement allows full access to tank for proper maintenance.
4. Narrow footprint allows clearance through doorways and down stairs.
5. Removable filter screen for easy maintenance.

**ENGINEER SPECIFICATION GUIDE**

Striem solids interceptor model PS-275-S shall be lifetime guaranteed and made in the USA. Interceptor shall be constructed of polyethylene. Interceptor shall be manufactured for above- or below-grade installation. Field-adjustable riser system is available as an option to bring manhole covers to grade. Interceptor shall have corrosion-resistant removable filter screen with 1/4" perforations. Interceptor liquid holding capacity shall be 250 gallons and solids capacity shall be 210 gallons. Covers shall provide water/gas-tight seal and have a maximum 16,000 lbs. load capacity.

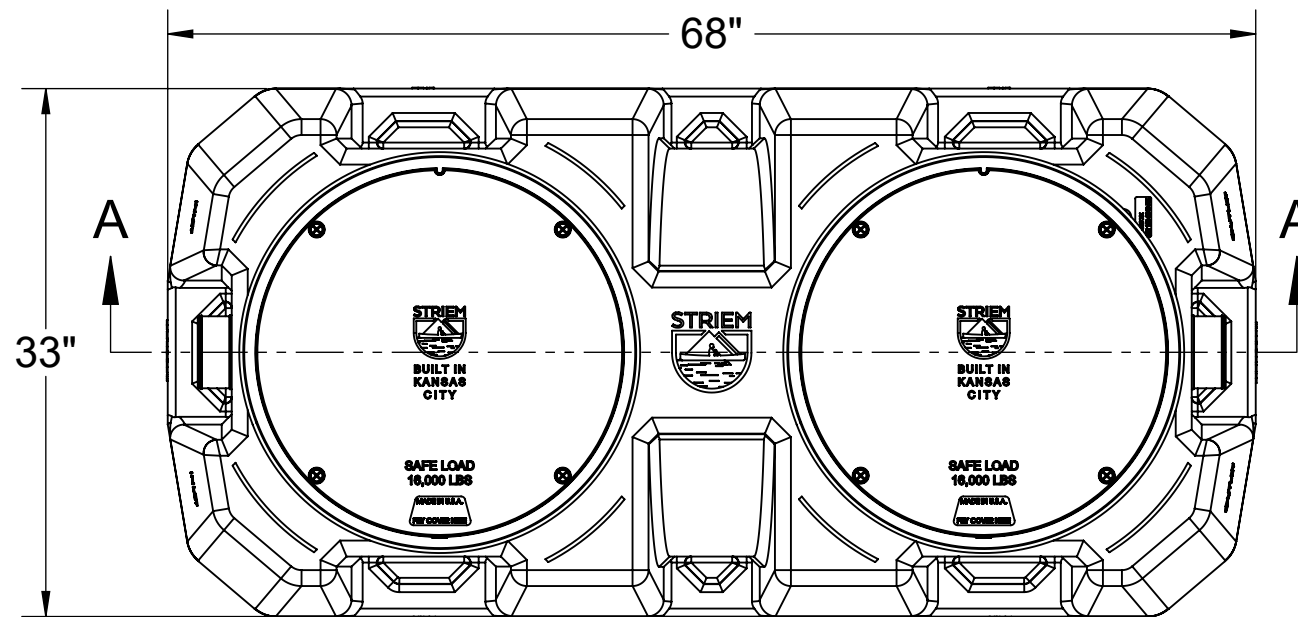

**TOP VIEW**

**OPTIONS**

**Connection Options (Plain End Only)**

**Inlet / Outlet**

- 4"
- 6"

**Riser Options**

**From Factory: Up to 5"**

- Up to 24": **SR24** (2)
- Up to 39": **LR24** (2)
- Up to 43": **SR24** (4)
- Up to 58": **SR24** (2) + **LR24** (2)
- Up to 72": **LR24** (4)
- Up to 90": **SR24** (2) + **LR24** (4)

**Additional Options**

- HDK-2:** High Water Anchor Kit
- C24-HP** (2): H2O Rated Pickable Cast Iron Covers

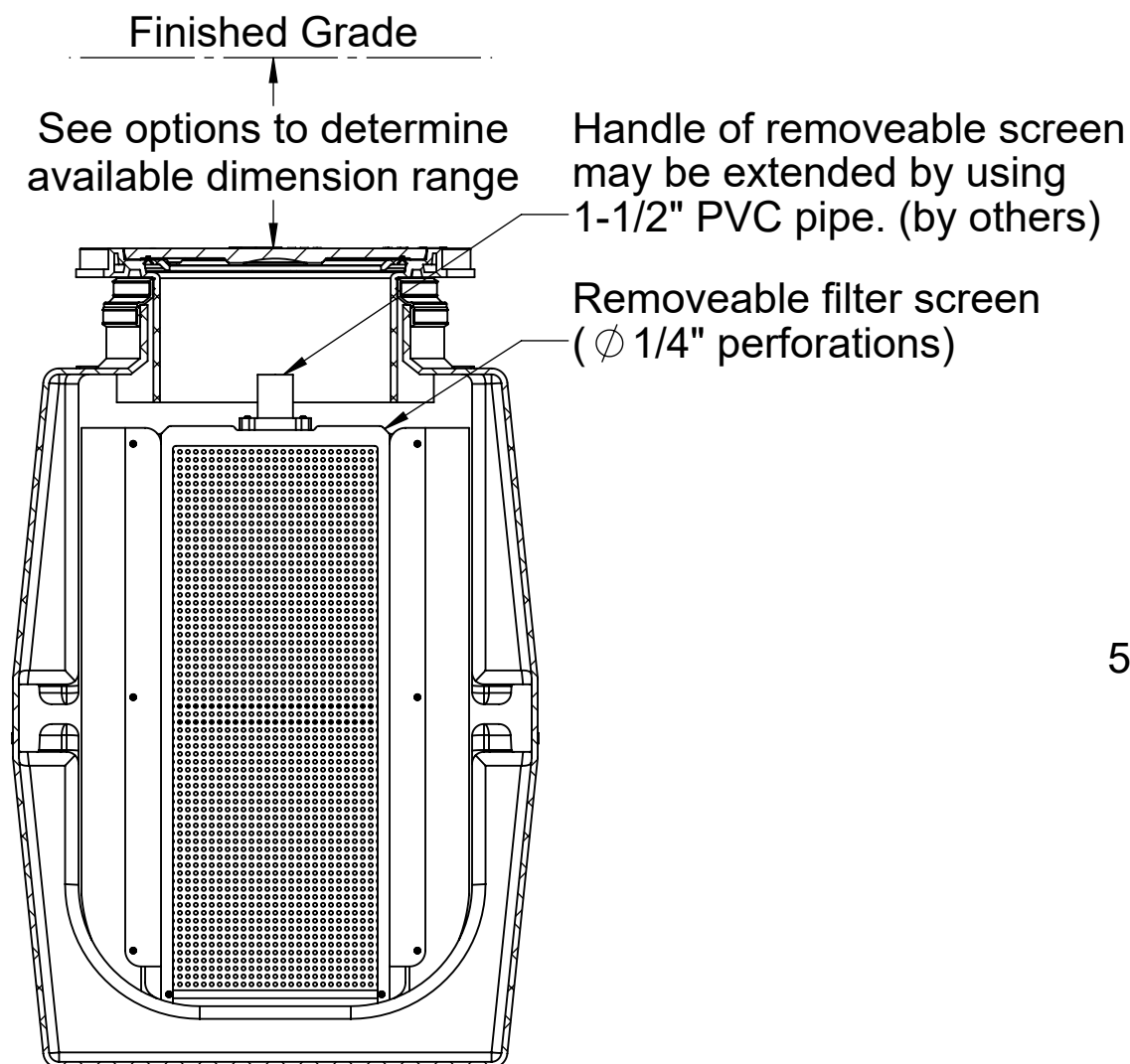

**SECTION B-B**

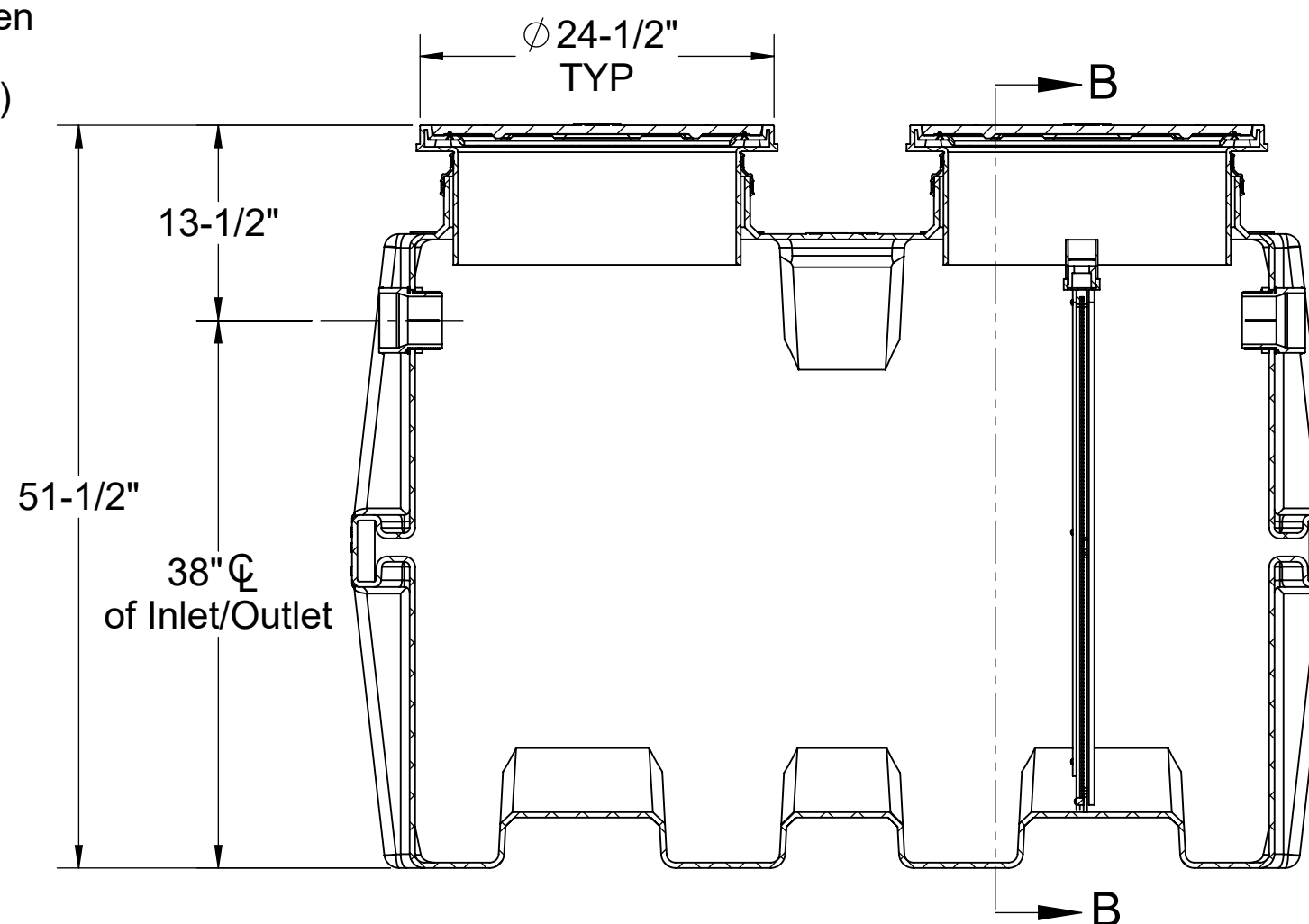

**SECTION A-A**

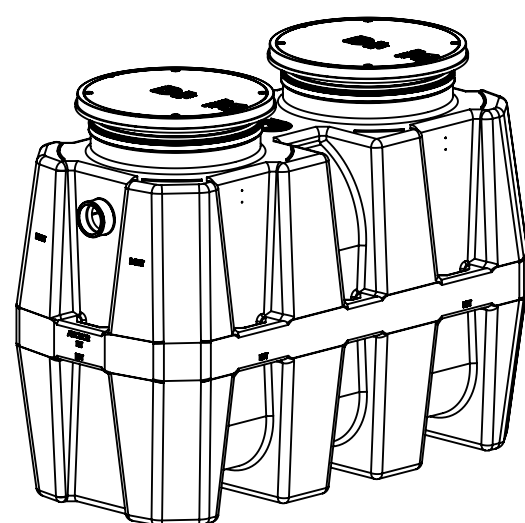

**PROPRIETARY AND CONFIDENTIAL**  
THE INFORMATION CONTAINED IN THIS DRAWING IS THE SOLE PROPERTY OF STRIEM, LLC. ANY REPRODUCTION IN PART OR AS A WHOLE WITHOUT THE WRITTEN PERMISSION OF STRIEM, LLC. IS PROHIBITED.

**MODEL NUMBER:** PS-275-S

**DESCRIPTION:**  
POLYETHYLENE SCREEN STYLE  
SOLIDS INTERCEPTOR  
250 LIQUID GALLON CAPACITY

**DWG BY:** ENG    **DATE:** 1/15/2024    **REV:** 2

**SPECIFICATION SHEET**

Striem  
Kansas City, KS  
Tel: 913-222-1500  
orders@striemco.com  
www.striemco.com

Made in the U.S.A

