

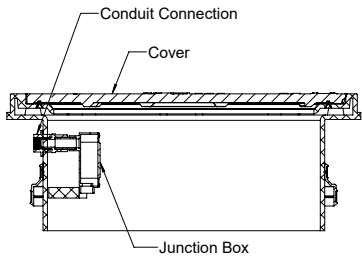

# SLICK STICK™ Oil Level Monitoring System INSTALLATION INSTRUCTIONS

- 1**
- Remove unit cover where interface float will be installed.
  - Remove the PVC fitting affixed to the junction box.



- 2**
- Cut the length of 1/2" PVC pipe referenced in the table to be used as the extension pipe.
  - If unit will be buried with an adjusted adapter or riser extensions, add the amount the height was adjusted to ensure correct placement of float switch.

$$\text{Table Length} + \text{Adjusted Height} = \text{Total length of } \frac{1}{2} \text{'' PVC Extension}$$

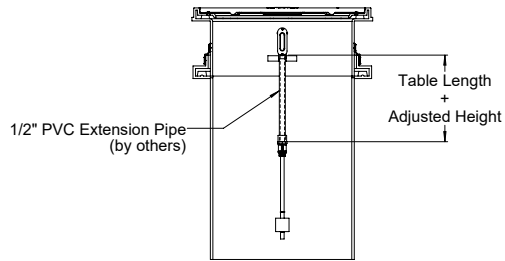

1/2" PVC Pipe Length

MONITORED OIL CAPACITY	OS-50	OS-75	OS-100	OT-500 - 2000
50%	1-1/2"	6-5/8"	9-5/8"	16"
70% <i>(Recommended)</i>	3-3/8"	10"	13-1/4"	19"
90%	5-1/2"	13-7/8"	18-3/4"	22"

*(For below-grade installations with adjusted adapter or riser extensions, add riser length to value in table)*

- 3**
- Thread the brass coupling onto the interface float stem.
  - Thread the 1/2" MPT x socket PVC fitting into the brass coupling.
  - Glue the PVC fitting to the extension pipe, and the extension pipe to the junction box.

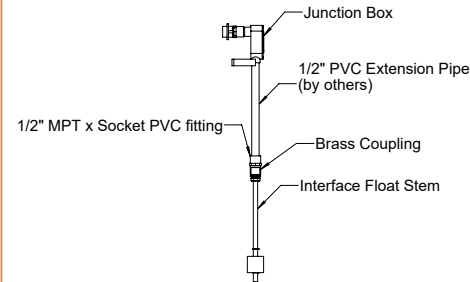

- 4**
- Run interface float wiring through the extension pipe and the bottom of the junction box.
  - Run control panel wiring through exterior conduit (by others) and tie together. Installation is complete.\*

*\* Once power is applied, alarm will sound until tank is filled with water.*

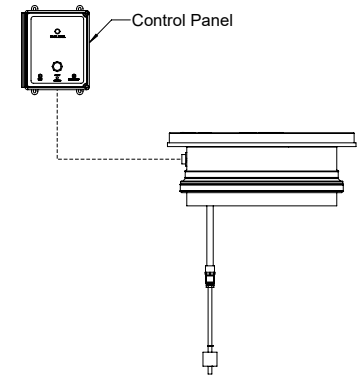

913-222-1500    HELP@STRIEMCO.COM    STRIEMCO.COM

CUSTOMER SERVICE HOURS: Mon-Fri, 8 am - 5 pm CST



# SLICK STICK™

## Oil Level Monitoring System

### WIRING DIAGRAM

Striem Slick Stick™ Wiring Diagram

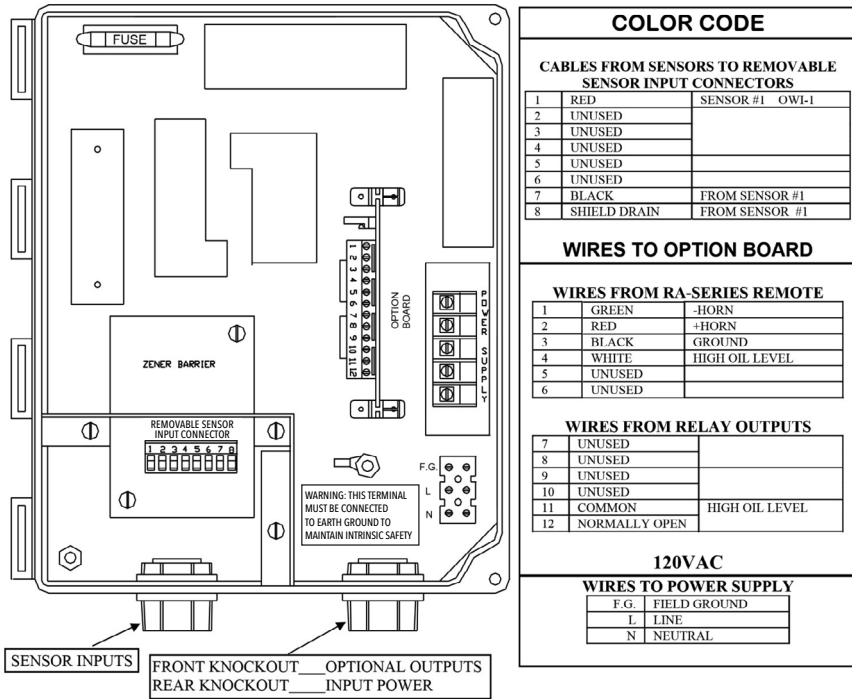

Striem Slick Stick™ System Control Drawing

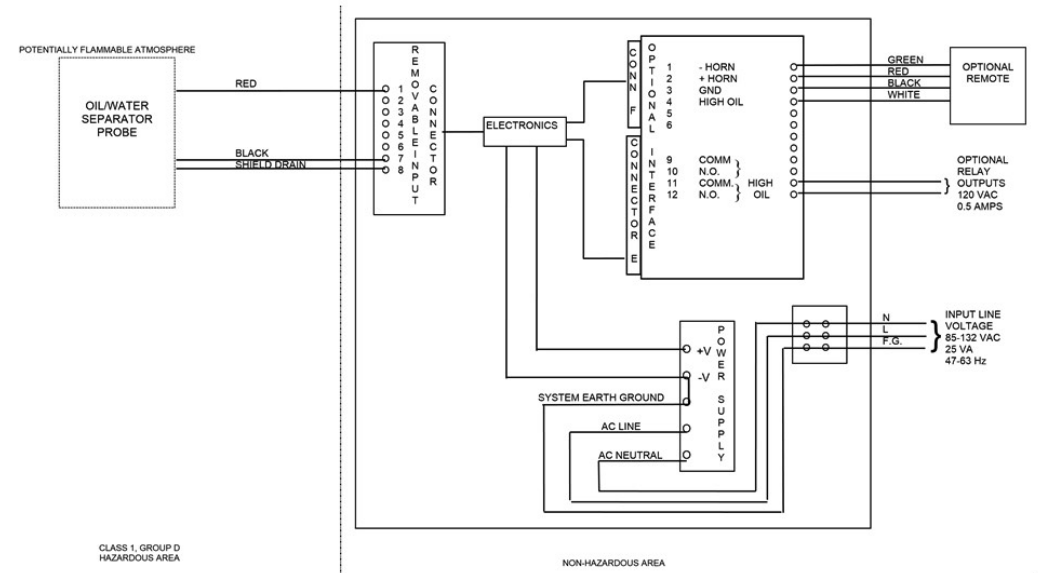

NOTES ON PROBES:

1. The intrinsically safe field wiring shall be installed in accordance with article 504 in the National Electrical Code ANSI/NFPA 70.
2. All probes are electrically identical and may be interchanged, allowing system flexibility.
3. Probe to control unit cable will be two pairs of #22 AWG with shield and drain PVC jacketed UL-118830 CM.
4. Cable length will be limited to 2,000 feet maximum.

NOTES ON CONTROL EQUIPMENT:

1. All wiring must meet local and national electrical codes.
2. System Earth ground must be connected to terminal F.G. to insure intrinsic safety and must be less than 1Ω with respect to Earth ground.
3. Optional remote requires #22 AWG low voltage communication cable minimum.



913-222-1500    HELP@STRIEMCO.COM    STRIEMCO.COM

CUSTOMER SERVICE HOURS: Mon-Fri, 8 am - 5 pm CST