



# BB-275

## DECONTAMINATION TANK

Installation, Operation, & Maintenance Guide

# BB-275

## DECONTAMINATION TANK

Installation, Operation, & Maintenance Guide

### OVERVIEW

Bio Basin™ model BB-275 is a 250 gallon polyethylene decontamination tank intended for above- or below-grade installation. It is designed to offer a safe and economical way to contain potentially hazardous liquid waste.

### OPERATION

Biological or contaminated liquid waste enters through the inlet connection where it is safely stored for testing, pumping, or to be released into the public sewer system after being determined suitable for evacuation.

### LIFETIME WARRANTY

Our products are designed to last the lifetime of the plumbing system in which they are installed. If they don't, we will repair or replace them at no charge. Product damage due to normal wear and tear may be repaired or replaced at a reasonable charge. See website for full details.

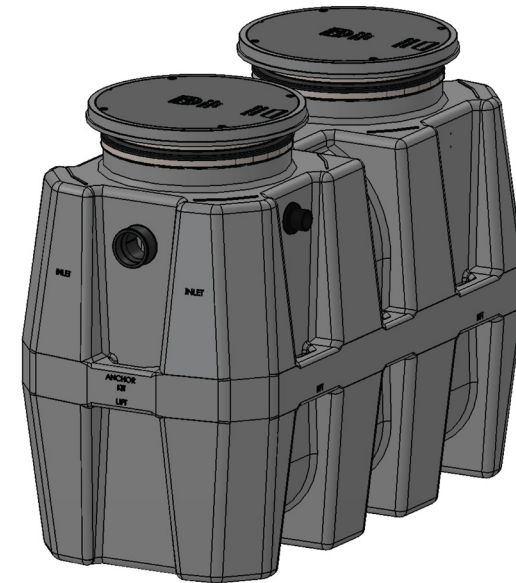

**BB-275**  
BIO BASIN SERIES  
250 GALLON  
DECONTAMINATION TANK



# WARNING



## DO NOT AIR PRESSURE TEST UNIT!

DOING SO MAY RESULT IN PROPERTY DAMAGE,  
SERIOUS BODILY INJURY, OR DEATH!

Refer to Installation Instructions for correct testing procedure.

### LEAK/SEAL TESTING

**Do not air test unit or Teleglide Riser system!** Doing so may result in property damage, personal injury or death.

To perform a leak/seal test on the base unit, cap/plug all plumbing connections, remove the cover, and fill the unit with water just above the highest connection. Inspect unit and connections for leaks. Check water level at specific time intervals per local code.

### MAINTENANCE

- 1 Always take proper care to ensure a safe and healthy environment while maintaining the decontamination tank.
- 2 Remove covers.
- 3 If the decontamination tank is not equipped with an outlet, then contact a professional pumper contractor to remove and dispose of the contents in the decontamination tank.
- 4 If the decontamination tank is equipped with an outlet, then verify the wastewater is acceptable to pass to the sewer system prior to evacuating the decontamination tank.
- 5 Inspect cover gaskets for wear and tear and reinsert covers.
- 6 Dispose of contents per local code.

### MAINTENANCE FREQUENCY

BB-275 must be maintained prior to reaching maximum capacity. Tank is considered to be at maximum capacity when liquid waste is at or near inlet connection. Maintenance procedure varies based on outlet options. Maintenance frequency depends on the frequency and amount of wastewater introduced to the system. Monitor wastewater levels to determine site specific maintenance schedule requirements.

### TROUBLESHOOTING TIPS



Slow drainage is cause for immediate inspection! Required maintenance depends on outlet option. Call a professional contractor for assistance. Call Striem for details on tank specifications.

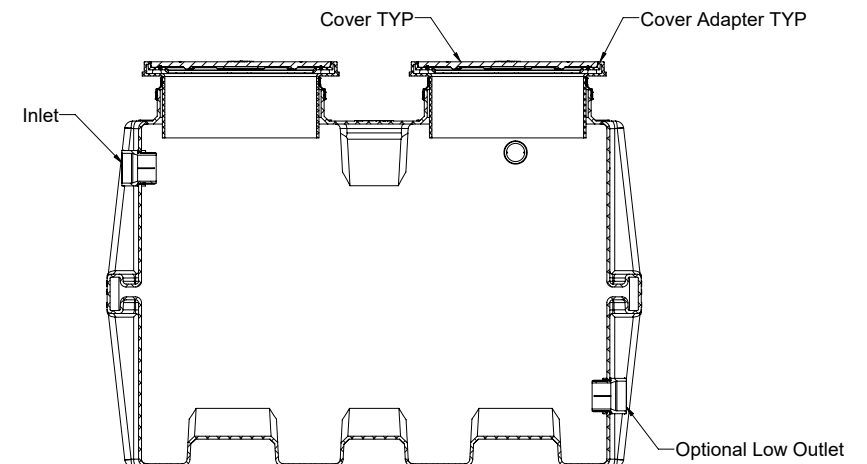

## ABOVE GRADE INSTALLATION INSTRUCTIONS

### UNIT INSTALLATION

- 1 Connect waste piping to unit via mechanical coupler.
- 2 Ensure covers are properly installed.

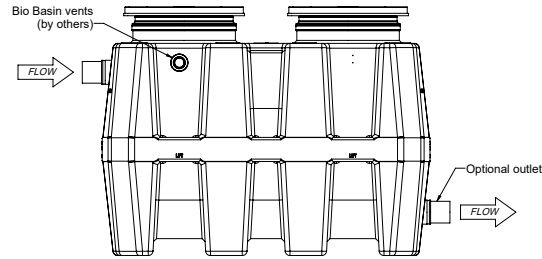

### ANCHOR KIT INSTALLATION STEPS

- 1 Slide Anchor Strap over tie down point on tank wall.
  - For units with no outlet, place the HDK-2 on the endwalls as shown in NO OUTLET INSTALLATION.
  - For units with an outlet, place the HDK-2 on the sidewalls as shown in WITH OUTLET INSTALLATION.
- 2 Bolt "Anchor Strap" to "Anchor Plate" using provided hardware.
- 3 Hold down force achieved by backfill weight acting on Anchor Plate.
- 4 Anchor Plate may be bolted to concrete slab, if required, by using holes provided in Anchor Plate.

## BELOW GRADE INSTALLATION INSTRUCTIONS

### EXCAVATION

- 1 Surrounding soil must be undisturbed soil or well compacted engineering fill.
- 2 Width and length of excavation shall be minimum 12" greater than the tank on all sides. If using HDK-2, width and length of excavation shall be minimum 18" greater than the tank on all sides.
- 3 Depth of excavation shall be 6" deeper than tank bottom.
- 4 Hold Down Kit is recommended for installations in high water table conditions to prevent float out. To be determined by specifying engineer. If necessary, order optional "High Water Hold Down Kit (HDK-2)". See detail adjacent.

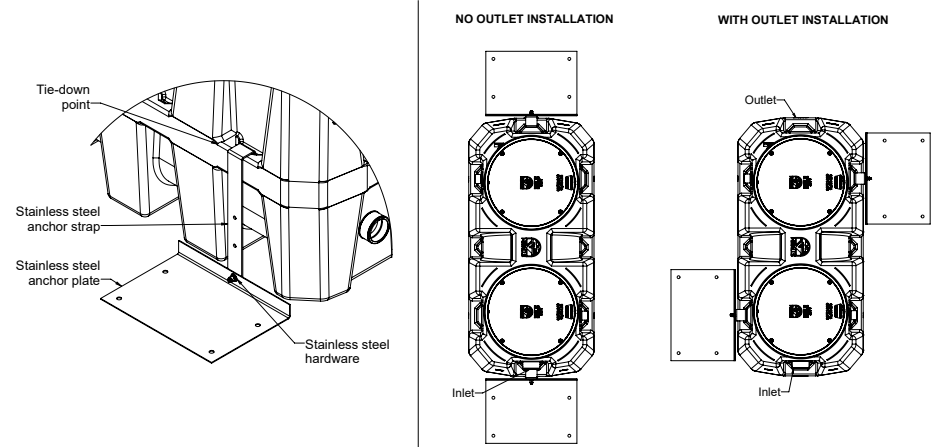
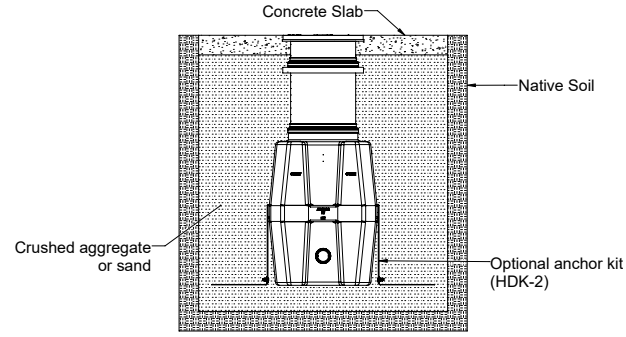

### UNIT INSTALLATION

- 1 Lower and center the unit into the excavated hole. Do not use chains or accessways to move the unit.
- 2 The water table must not exceed the tank height prior to the addition of risers.
- 3 Ensure the unit cover is level with finished grade.
- 4 Fill BB-275 with water before backfilling to stabilize the unit and prevent float out during backfilling.
- 5 After unit has been properly installed, evacuate water from BB-275 to prepare for contaminated wastewater.

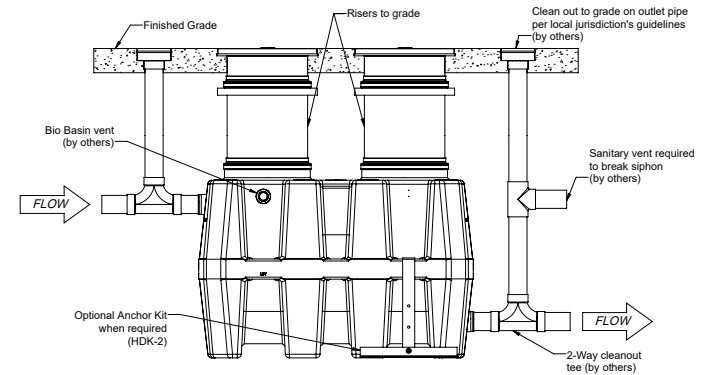

### BACKFILLING & FINISHED CONCRETE SLAB

- 1 Preparation of sub grade per geotech recommendations.
- 2 Stabilize and compact sub grade to 95% proctor.
- 3 Before backfilling and pouring of slab, secure cover and risers (if used) to the unit.
- 4 Place 6" aggregate base under slab. Aggregate should be 3/4" size rock, or sand, with no fines.
- 5 Backfill using crushed aggregate material approximately 3/4" size rock, or sand, with no fines.
- 6 Thickness of concrete slab around the covers to be 8" for traffic loading. Thickness of concrete slab around the covers to be 4" for pedestrian or greenspace areas.
- 7 Concrete slab cannot interfere with the tank body below the risers.
- 8 Concrete to be 28 day compressive strength to 4000 PSI with 6 ± 1% air entrainment.
- 9 NO. 4 rebar (1/2") grade 60 steel per ASTM A615: connected with tie wire.
- 10 Rebar to be 2 1/2" from edge of concrete.
- 11 Rebar spacing 12" grid. 4" spacing around access opening.

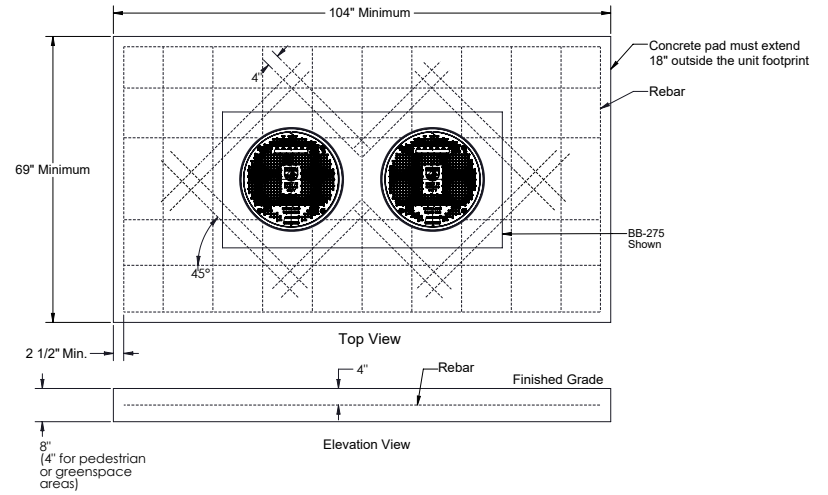

## TELEGLIDE RISER | INSTALLATION INSTRUCTIONS

CORRUGATED PIPE RISER KIT (CPRK) AVAILABLE AS ALTERNATE RISER SOLUTION. SEE CPRK INSTALLATION INSTRUCTIONS FOR MORE DETAILS.

- 1 Place BB-275 so that the pipe connections line up with jobsite piping. Measure dimension X to determine riser height needed. Select the required risers from the adjacent table. Riser chart shows quantity for each tank manway.

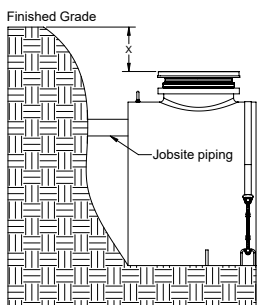

Standard Cover Adapter	
Riser Height Needed	Risers Required Per Manway
0" - 5"	None
5" - 24"	SR24 (1)
24" - 39"	LR24 (1)
39" - 43"	SR24 (2)
43" - 58"	SR24 (1), LR24 (1)
58" - 72"	LR24 (2)

- 2 Loosen upper clamp with nut driver bit (included with tank). If no risers are needed, adjust cover adapter height as needed. Ensure 2-1/2" minimum engagement is maintained. If risers are needed, remove cover from cover adapter, and cover adapter from the unit.

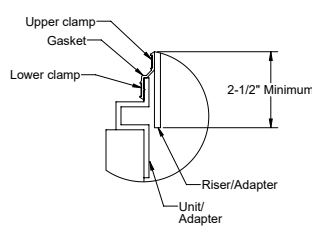

- 3 Insert cover adapter into the required risers until they stop. Tighten upper clamp to keep risers from shifting. Risers are installed from short to long. If using a standard cover adapter, measure the riser height needed, X + 5.25" down the sidewall of the risers. Mark the location with china marker (included with tank). Cover adapter may need to be adjusted outward for some dimension ranges. If mark is at the end of riser, no cutting is required.

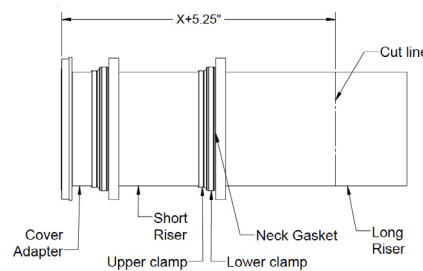

- 4 Uninstall cover adapter and risers. Extend mark made in step 3 around the circumference of the riser. Cut along line with jigsaw, circular saw, or reciprocating saw. Make a mark around the circumference of the riser 3" from the cut end of riser. If no cuts were needed, make the mark 3" from the bottom of the bottom riser.

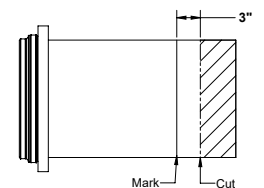

- 5 Wipe clean all riser and cover adapter sidewalls. Insert the first riser into the tank neck until the mark made in step 4 is in-line with the top of the neck gasket. This will ensure your risers reach the finished grade measured in step 1.

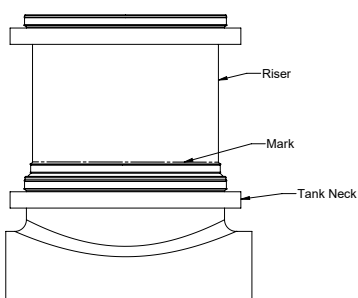

- 6 Install risers and cover adapter into the tank neck starting from the marked riser, moving up to finished grade. Upper clamps may need to be loosened or removed to aid in assembly.

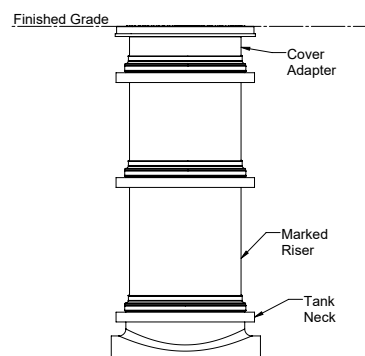

- 7 Tighten all clamps to 14 lbs. of torque. Reinstall cover on cover adapter. If tilting of the cover adapter is required to be flush with finished floor, it must be done after all clamps are tightened. A 6.5° tilt is the maximum.

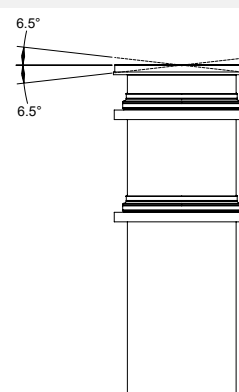

- 8 If jobsite riser height conditions change after the previous steps have been completed, there is still room for vertical adjustment. As long as the minimum engagement of 2-1/2" on all joints are maintained, the adapter and risers may be adjusted/cut as many times as necessary.

