



CB-500-S

CATCH BASIN

Installation, Operation, & Maintenance Guide

CB-500-S

CATCH BASIN

Installation, Operation, & Maintenance Guide

OVERVIEW

Striem Settler™ series model CB-500-S is a 500 gallon polyethylene catch basin intended for below grade installation. It is designed to separate heavy sand and sediment from the waste stream.

OPERATION

Solids laden wastewater enters through the inlet connection. In the settling chamber, heavy debris settles to the bottom before the wastewater exits through the outlet.

LIFETIME WARRANTY

Our products are designed to last the lifetime of the plumbing system in which they are installed. If they don't, we will repair or replace them at no charge. Product damage due to normal wear and tear may be repaired or replaced at a reasonable charge. See website for full details.

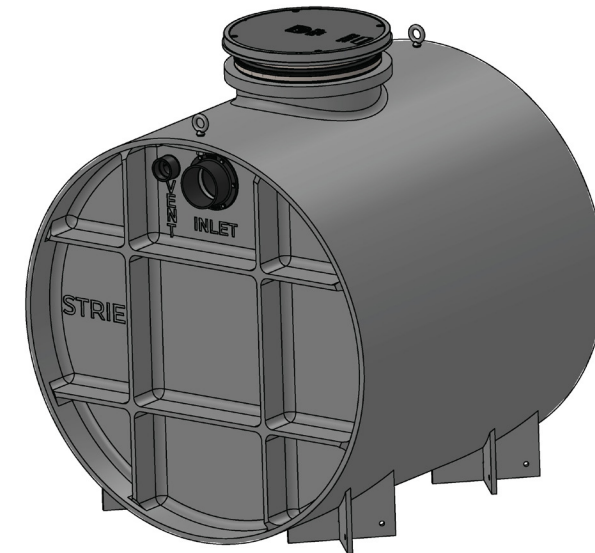

CB-500-S
SETTLER SERIES
500 GAL
CATCH BASIN

913-222-1500 HELP@STRIEMCO.COM STRIEMCO.COM

CUSTOMER SERVICE HOURS: 8 AM - 5 PM CST



WARNING

DO NOT AIR PRESSURE TEST UNIT!
DOING SO MAY RESULT IN PROPERTY DAMAGE,
SERIOUS BODILY INJURY, OR DEATH!

Refer to Installation Instructions for correct testing procedure.

FOR BURIED APPLICATIONS ONLY

LEAK/SEAL TESTING

Do not air test unit or Teleglide Riser system! Doing so may result in property damage, personal injury or death.

To perform a leak/seal test on the base unit, cap/plug all plumbing connections, remove the cover, and fill the unit with water just above the highest connection. Inspect unit and connections for leaks. Check water level at specific time intervals per local code. Note: This unit has been subjected to a 24 hour water test prior to shipment from the factory.

MAINTENANCE

- 1 Always take proper care to ensure a safe and healthy environment while maintaining the catch basin.
- 2 Remove cover.
- 3 Remove all contents from the main body of the CB-500-S, including wastewater, debris, and sediment. Contact a professional pumper contractor for best results.
- 4 Clean drain lines and diptube thoroughly of all debris.
- 5 Fill CB-500-S with water to invert of outlet.
- 6 Inspect cover gasket for wear and tear and replace cover.
- 7 Dispose of contents per local code.

MAINTENANCE FREQUENCY

Maintenance frequency depends on the quantity, size, and contents of solids entering the catch basin. Striem recommends inspecting the unit every one to three months until a proper maintenance schedule can be established.

Debris and sludge must be cleaned out periodically to allow the free flow of wastewater through the unit.

TROUBLESHOOTING TIPS

Slower than usual drainage may indicate a blockage and a need to maintain the catch basin. Ensure the drain lines and diptube are cleared of all debris in the presence of slow drainage.

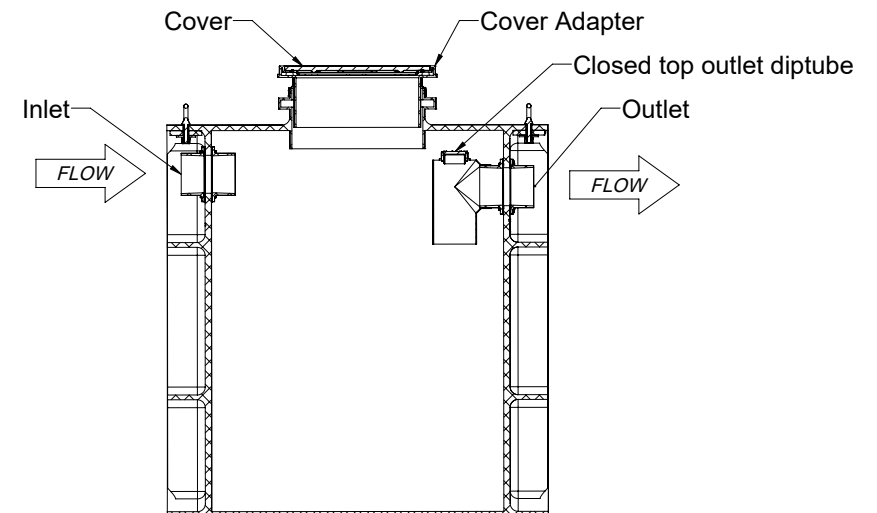

INSTALLATION

EXCAVATION

- 1 Surrounding soil must be undisturbed soil or well compacted engineering fill.
- 2 Measure the width and length of the tank and excavate a hole that is a minimum of 18" greater than the tank on all sides.
- 3 Depth of excavation shall be 12" deeper than tank bottom.
- 4 After the excavation is complete create a well compacted support layer of sand/gravel mixture so that ground supporting tank is a minimum of 12" above native soil.

UNIT INSTALLATION

- 1 Lower and center the unit into hole using Striem lifting lug kit (included). Do not use chains or accessways to move the unit.
- 2 The water table must not exceed the tank height prior to the addition of risers.
- 3 Ensure the unit cover is level with finished grade.
- 4 Fill CB-500-S with water before backfilling to stabilize the unit and prevent float out during backfilling.

BACKFILLING & FINISHED CONCRETE SLAB

- 1 Before backfilling and pouring of the slab, secure cover and risers (if necessary) to the unit.
- 2 Backfill evenly all around the tank using crushed aggregate material approximately 3/4" size rock, or sand, with no fines.
- 3 When backfilling, ensure backfill is worked under the unit using a probe to ensure the unit is fully supported.
- 4 Place 6" aggregate base under slab. Aggregate should be 3/4" size rock, or sand, with no fines.
- 5 Thickness of concrete slab around the covers to be 8" for traffic loading. Thickness of concrete slab around the covers to be 4" for pedestrian or greenspace areas.
- 6 Concrete slab cannot interfere with the tank body below the risers.
- 7 Concrete to be 28 day compressive strength to 4000 PSI with 6 ± 1% air entrainment.
- 8 NO. 4 rebar (1/2") grade 60 steel per ASTM A615: connected with tie wire.
- 9 Rebar to be 2 1/2" from edge of concrete.
- 10 Rebar spacing 12" grid. 4" spacing around access openings.

DEADMAN ANCHORING (IF NECESSARY)

- 1 Deadmen should be constructed according to the American Concrete Institute (ACI) code.
- 2 Deadmen should be 12" wide x 12" tall and 60" long.
- 3 Each deadman should have (2) anchor points for connection to (2) 3,500 lbs. rated turnbuckles.
- 4 The deadmen shall be installed tangent to the tank footprint.
- 5 Pre-fabricated straps rated to 3,333 lbs. each should be connected to a turnbuckle on each side. Turnbuckles should be secured to the deadmen anchor points on each side of the tank such that the tank is held down.

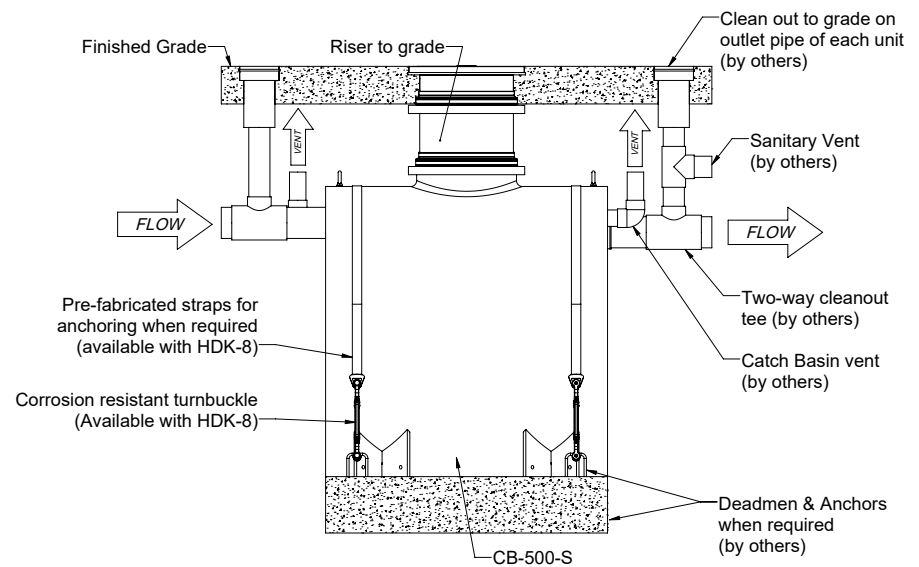
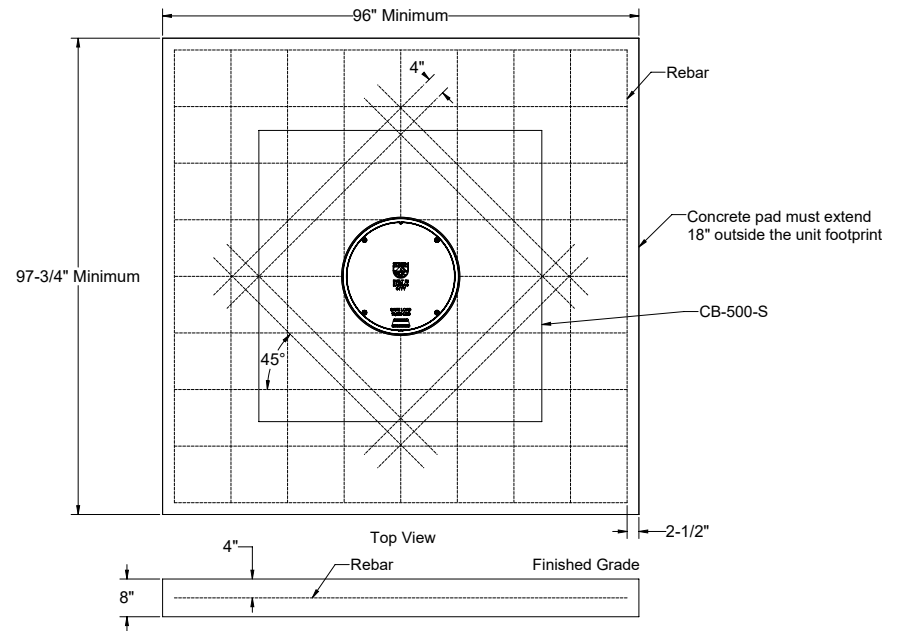
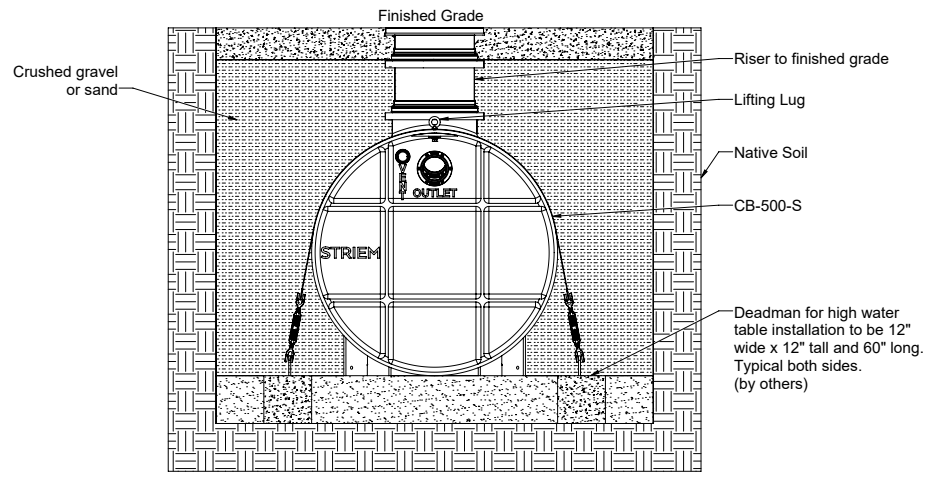

TELEGLIDE RISER | INSTALLATION INSTRUCTIONS

CORRUGATED PIPE RISER KIT (CPRK) AVAILABLE AS ALTERNATE RISER SOLUTION. SEE CPRK INSTALLATION INSTRUCTIONS FOR MORE DETAILS.

- 1 Place unit so that the pipe connections line up with jobsite piping. Measure dimension X to determine riser height needed. Select the required risers from the adjacent table. Riser chart shows quantity for each tank manway.

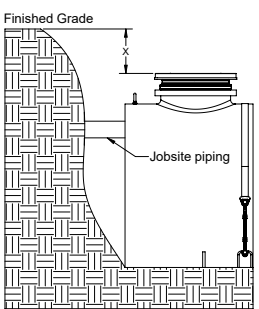

Standard Cover Adapter	
Riser Height Needed	Risers Required Per Manway
0" - 5"	None
5" - 24"	SR24 (1)
24" - 39"	LR24 (1)
39" - 43"	SR24 (2)
43" - 58"	SR24 (1), LR24 (1)
58" - 72"	LR24 (2)
72" - 90"	SR24 (1), LR24 (2)
90" - 106"	LR24 (3)

- 2 Loosen upper clamp with nut driver bit (included with tank). If no risers are needed, adjust cover adapter height as needed. Ensure 2-1/2" minimum engagement is maintained. If risers are needed, remove cover from cover adapter, and cover adapter from the unit.

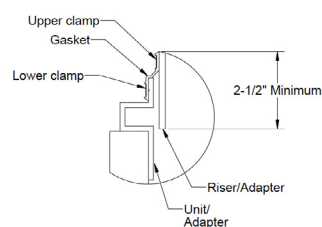

- 3 Insert cover adapter into the required risers until they stop. Tighten upper clamp to keep risers from shifting. Risers are installed from short to long. If using a standard cover adapter, measure the riser height needed, X + 5.25" down the sidewall of the risers. Mark the location with china marker (included with tank). Cover adapter may need to be adjusted outward for some dimension ranges. If mark is at the end of riser, no cutting is required.

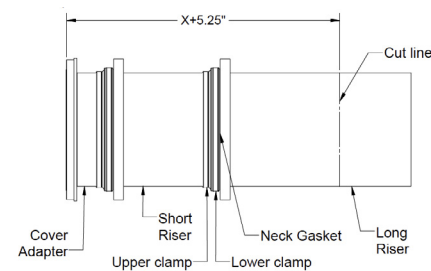

- 4 Uninstall cover adapter and risers. Extend mark made in step 3 around the circumference of the riser. Cut along line with jigsaw, circular saw, or reciprocating saw. Make a mark around the circumference of the riser 3" from the cut end of riser. If no cuts were needed, make the mark 3" from the bottom of the bottom riser.

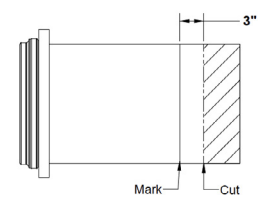

- 5 Wipe clean all riser and cover adapter sidewalls. Insert the first riser into the tank neck until the mark made in step 4 is in-line with the top of the neck gasket. This will ensure your risers reach the finished grade measured in step 1.

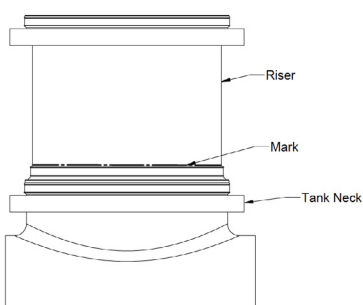

- 6 Install risers and cover adapter into the tank neck starting from the marked riser, moving up to finished grade. Upper clamps may need to be loosened or removed to aid in assembly.

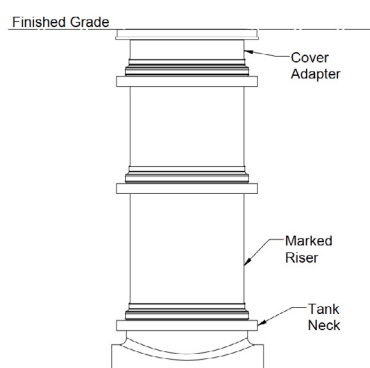

- 7 Tighten all clamps to 14 lbs. of torque. Reinstall cover on cover adapter. If tilting of the cover adapter is required to be flush with finished floor, it must be done after all clamps are tightened. A 6.5° tilt is the maximum.

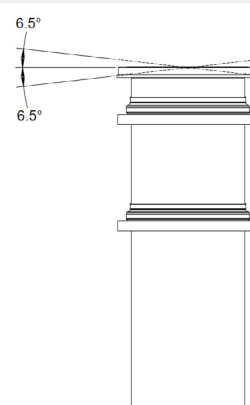

- 8 If jobsite riser height conditions change after the previous steps have been completed, there is still room for vertical adjustment. As long as the minimum engagement of 2-1/2" on all joints are maintained, the adapter and risers may be adjusted/cut as many times as necessary.

