

**SPECIFICATIONS**

1. 4" Plain End inlet/outlet, 3" Plain End vents, C24-H cover standard.
2. Liquid capacity: 262 Gallons (35 cu. ft.).
3. Solids capacity: 145 Gallons (19.4 cu. ft.).
4. Flammable waste capacity: 105 Gallons (14 cu. ft.).
5. Unit weight w/ standard cover: 175 lbs.; w/ cast iron cover: 235 lbs.
6. Maximum operating temperature 140°F continuous.
7. Minimum burial depth: 12".

**ENGINEER SPECIFICATION GUIDE**

Striem flammable waste trap model FWT-35 shall be lifetime guaranteed and made in the USA. FWT-35 shall be constructed of polyethylene. FWT-35 shall be manufactured for above- or below-grade installation. Field-adjustable riser system is available as an option to bring manhole cover to grade. FWT-35 liquid holding capacity shall be 262 gallons and flammable waste capacity shall be 105 gallons. Solids capacity shall be 145 gallons. Cover shall provide water/gas-tight seal and have a maximum 16,000 lbs. load capacity.

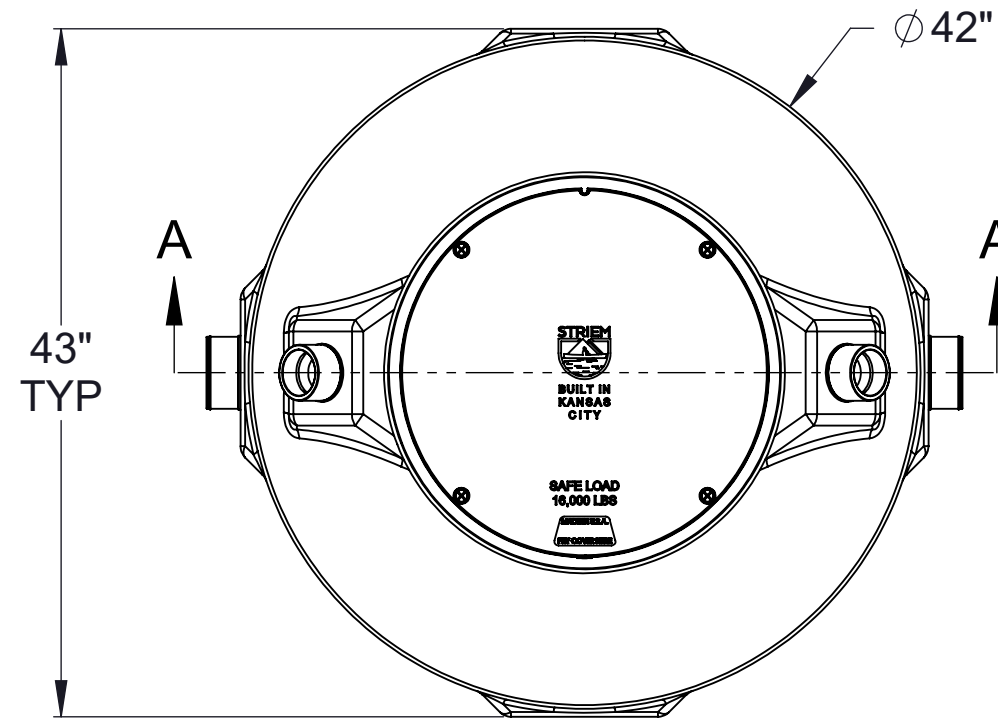

**TOP VIEW**

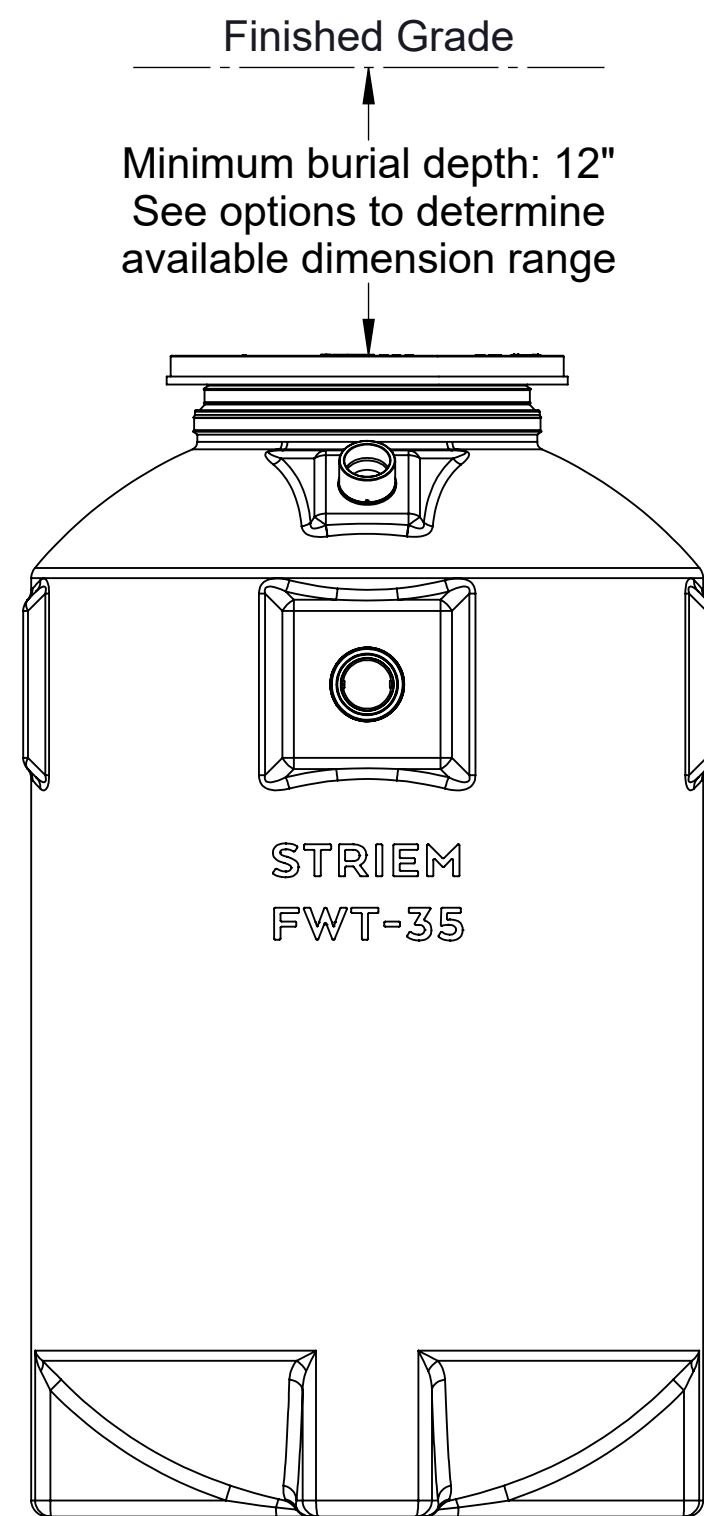

**END VIEW**

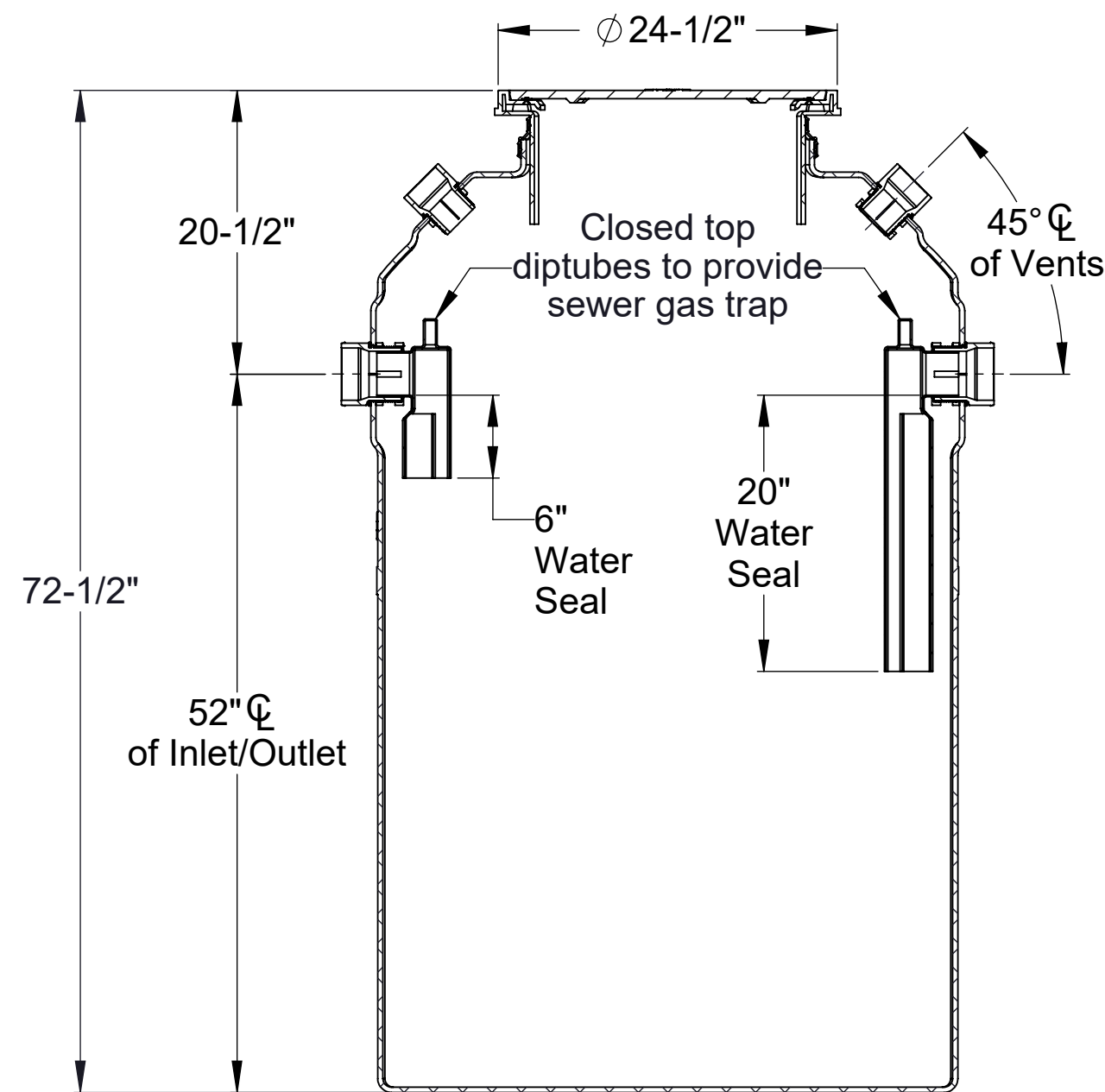

**SECTION A-A**

OPTIONS	
<b>Connection Options (Plain End Only)</b>	
<b>Inlet / Outlet</b>	
<input type="checkbox"/> 4"	
<input type="checkbox"/> 6"	
<b>Riser Options</b>	
<b>Minimum Burial Depth: 12"</b>	
<input type="checkbox"/> Up to 24": <b>SR24</b>	
<input type="checkbox"/> Up to 39": <b>LR24</b>	
<input type="checkbox"/> Up to 43": <b>SR24 (2)</b>	
<input type="checkbox"/> Up to 58": <b>SR24 + LR24</b>	
<input type="checkbox"/> Up to 72": <b>LR24 (2)</b>	
<input type="checkbox"/> Up to 90": <b>SR24 + LR24 (2)</b>	
<b>- OR -</b>	
<input type="checkbox"/> <b>CPRK: 12" - 90"</b> (See specification for more detail.)	
<b>Additional Options</b>	
<input type="checkbox"/> <b>C24-HP: H2O Rated Pickable Cast Iron Cover</b>	
<input type="checkbox"/> <b>HDK-10: High Water Table Hold Down Kit</b>	
<input type="checkbox"/> <b>SS: Slick Stick™ Oil Level Monitoring System*</b>	
*Monitoring package will raise cover by 3"	

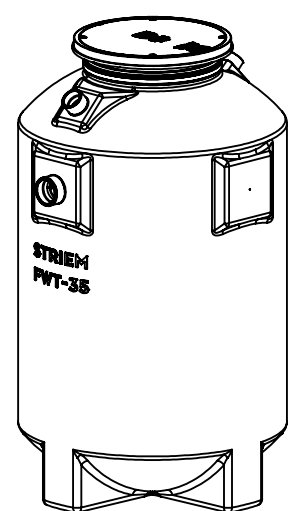

<b>MODEL NUMBER:</b>	FWT-35
<b>DESCRIPTION:</b>	35 CUBIC FEET POLYETHYLENE FLAMMABLE WASTE TRAP, UNRATED
<b>DWG BY:</b>	ENG
<b>DATE:</b>	6/4/2024
<b>REV:</b>	1

**SPECIFICATION SHEET**

Striem  
 Kansas City, KS  
 Tel: 913-222-1500  
 orders@striemco.com  
 www.striemco.com

Made in the U.S.A

