

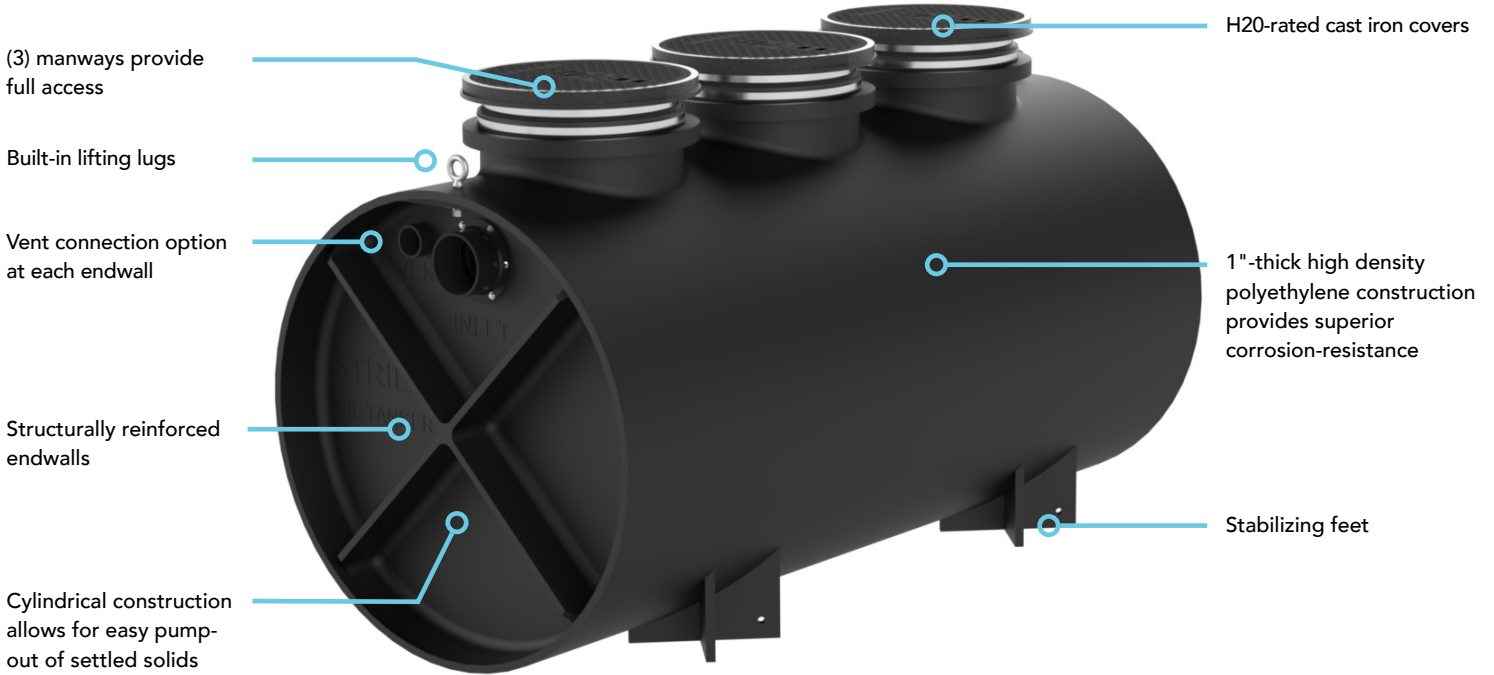

OIL TANKER™ SERIES

VOLUME-BASED OIL SEPARATORS

THE INDUSTRY'S FIRST CERTIFIED POLYETHYLENE OIL SEPARATOR



(OT-500 shown)

CHECK OUT OUR
**ONLINE
SIZING TOOL.**



Listed by IAPMO
to IGC 183-2016

APPLICATIONS



AUTO SERVICE/
REPAIR STATIONS



FIRE HOUSE/
POLICE STATIONS



PARKING
GARAGES

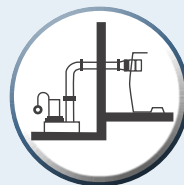

HYDRAULIC
ELEVATOR PITS



CAR WASHES



LOADING
DOCKS



AIRPORTS /
HANGARS



**LIFETIME
GUARANTEED**

913-222-1500 HELP@STRIEMCO.COM

STRIEMCO.COM

**MADE
IN THE
USA**
* BUILT in *
KANSAS CITY



OIL TANKER™ SERIES

VOLUME-BASED OIL SEPARATORS

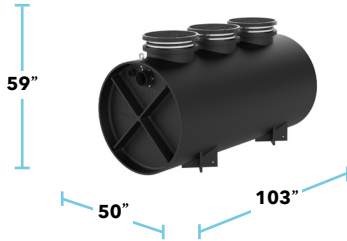

OT-500

CONNECTIONS: 4", 6", or 8" **OIL CAPACITY:** 285 GAL.
MAX FLOW RATE: 314 GPM **SAND CAPACITY:** 162 GAL.
LIQUID CAPACITY: 560 GAL.

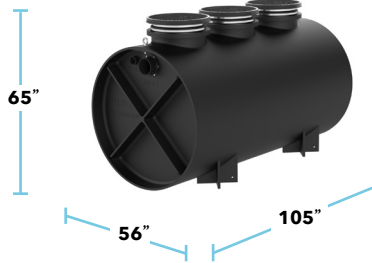

OT-750

CONNECTIONS: 4", 6", or 8" **OIL CAPACITY:** 323 GAL.
MAX FLOW RATE: 314 GPM **SAND CAPACITY:** 295 GAL.
LIQUID CAPACITY: 750 GAL.

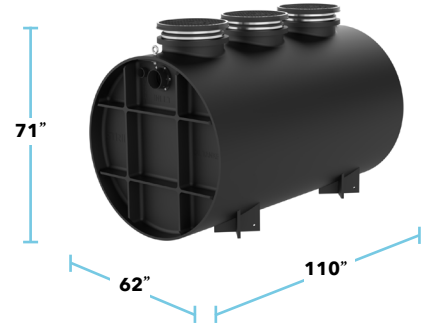

OT-1000

CONNECTIONS: 4", 6", or 8" **OIL CAPACITY:** 370 GAL.
MAX FLOW RATE: 314 GPM **SAND CAPACITY:** 477 GAL.
LIQUID CAPACITY: 1,000 GAL.

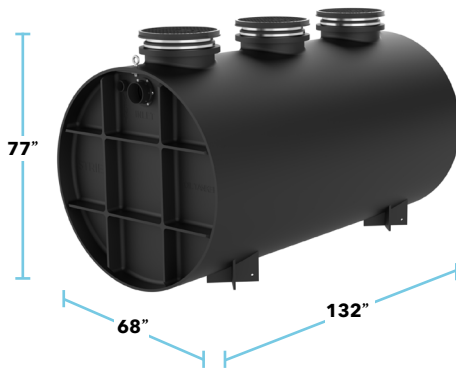

OT-1500

CONNECTIONS: 4", 6", or 8" **OIL CAPACITY:** 488 GAL.
MAX FLOW RATE: 314 GPM **SAND CAPACITY:** 825 GAL.
LIQUID CAPACITY: 1,500 GAL.

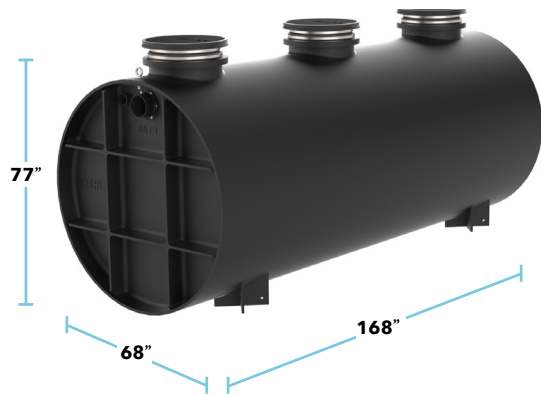

OT-2000

CONNECTIONS: 4", 6", or 8" **OIL CAPACITY:** 638 GAL.
MAX FLOW RATE: 314 GPM **SAND CAPACITY:** 1,077 GAL.
LIQUID CAPACITY: 2,000 GAL.

OPTIONS

- SR/LR field-adjustable extensions
- Corrugated Pipe Riser Kit (CPRK)
- High water hold down kits
- Slick Stick™ oil level monitoring system
- Coalescing media

SPEC FORMATS



*AVAILABLE ONLINE FOR ALL PRODUCTS



**LIFETIME
GUARANTEED**

913-222-1500 HELP@STRIEMCO.COM

STRIEMCO.COM

**MADE
IN THE
USA**
* BUILT in *
KANSAS CITY