



PS-50-S

SOLIDS INTERCEPTOR

Installation, Operation, & Maintenance Guide

PS-50-S

SOLIDS INTERCEPTOR

Installation, Operation, & Maintenance Guide

OVERVIEW

Striem Prospector™ model PS-50-S is a 57 gallon polyethylene solids interceptor intended for above- or below-grade installation. It is designed to separate heavy and suspended solids from in-line drainage applications before entering the public sewer or private septic system system by means of a removable screen.

OPERATION

Solids laden wastewater enters through the inlet connection. Heavy solids settle to the bottom of the unit, while the remaining solids are filtered from the waste stream by the removable screen.

LIFETIME WARRANTY

Our products are designed to last the lifetime of the plumbing system in which they are installed. If they don't, we will repair or replace them at no charge. Product damage due to normal wear and tear may be repaired or replaced at a reasonable charge. See website for full details.

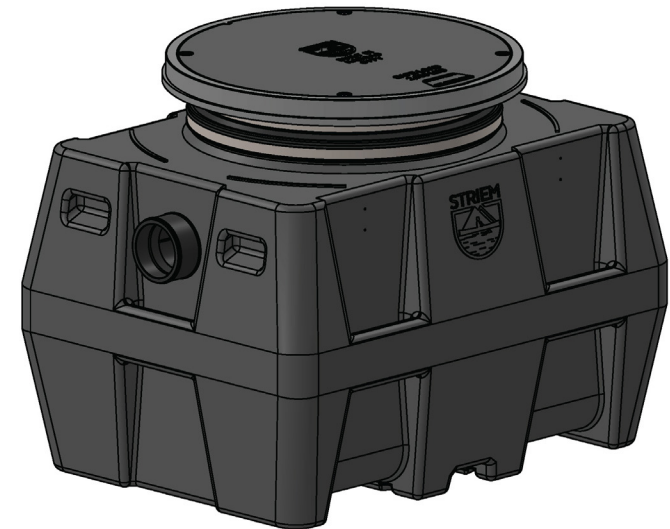

PS-50-S
57 GAL
SOLIDS INTERCEPTOR

913-222-1500 HELP@STRIEMCO.COM STRIEMCO.COM

CUSTOMER SERVICE HOURS: 8 AM - 5 PM CST



WARNING



DO NOT AIR PRESSURE TEST UNIT!

DOING SO MAY RESULT IN PROPERTY DAMAGE,
SERIOUS BODILY INJURY, OR DEATH!

Refer to Installation Instructions for correct testing procedure.

LEAK/SEAL TESTING

Do not air test unit or Teleglide Riser system! Doing so may result in property damage, personal injury or death.

To perform a leak/seal test on the base unit, cap/plug all plumbing connections, remove the cover, and fill the unit with water just above the highest connection. Inspect unit and connections for leaks. Check water level at specific time intervals per local code.

MAINTENANCE

- 1 Always take proper care to ensure a safe and healthy environment while maintaining the solids interceptor.
- 2 Remove cover.
- 3 Remove all contents from the body of the PS-50-S, including solids and wastewater. Contact a professional pumper contractor for the best results.
- 4 Clean drain lines thoroughly of all debris.
- 5 Remove screen and clean if necessary.
- 6 Replace screen.
- 7 Fill PS-50-S with water to invert of outlet.
- 8 Inspect cover gasket for wear and tear and replace cover.
- 9 Dispose of contents per local code.

MAINTENANCE FREQUENCY

Maintenance frequency depends on the quantity, size, and contents of solids entering the solids interceptor. Striem recommends inspecting the unit every one to three months until a proper maintenance schedule can be established.

The body and screen must be maintained periodically to allow the free flow of wastewater through the unit.

TROUBLESHOOTING TIPS



Slower than usual drainage may indicate a blockage and a need to maintain the solids interceptor. Ensure the drain lines and removable screen are cleared of all debris in the presence of slow drainage.

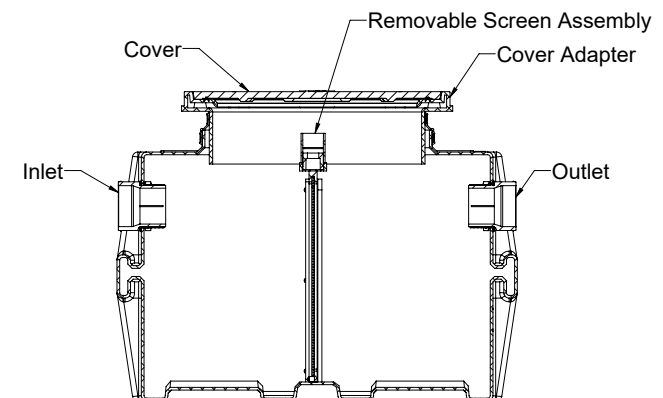

ABOVE GRADE INSTALLATION INSTRUCTIONS

UNIT INSTALLATION

- 1 Connect waste piping to unit.
- 2 Fill PS-50-S with water to outlet invert.
- 3 Ensure cover is properly installed.

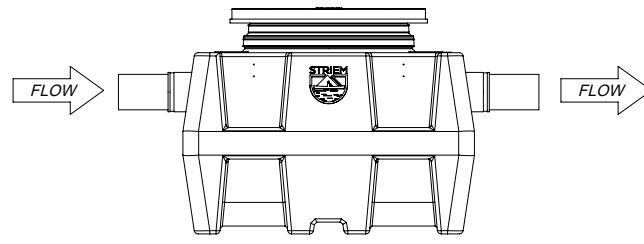

BELOW GRADE INSTALLATION INSTRUCTIONS

EXCAVATION

- 1 Surrounding soil must be undisturbed soil or well compacted engineering fill.
- 2 Width and length of excavation shall be minimum 12" greater than the tank on all sides.
- 3 Depth of excavation shall be 6" deeper than tank bottom.
- 4 Anchor kit is recommended for installations in high water table conditions to prevent float out. To be determined by specifying engineer. If necessary, order optional "High Water Anchor Kit (HDK-2)". See detail adjacent.

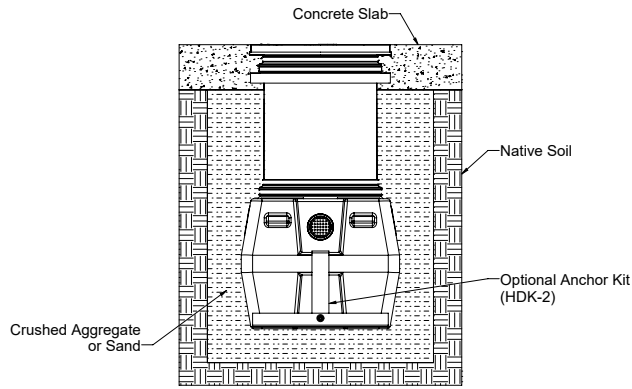

ANCHOR KIT INSTALLATION STEPS

- 1 Cut anchor strap to length with 4" grinder with metal cut-off wheel.
- 2 Slide Anchor Strap over tie down point on end wall.
- 3 Bolt Anchor Strap to Anchor Plate using provided hardware.
- 4 Hold down force achieved by backfill weight acting on Anchor Plate.
- 5 Anchor Plate may be bolted to concrete slab, if required, by using holes provided in Anchor Plate.

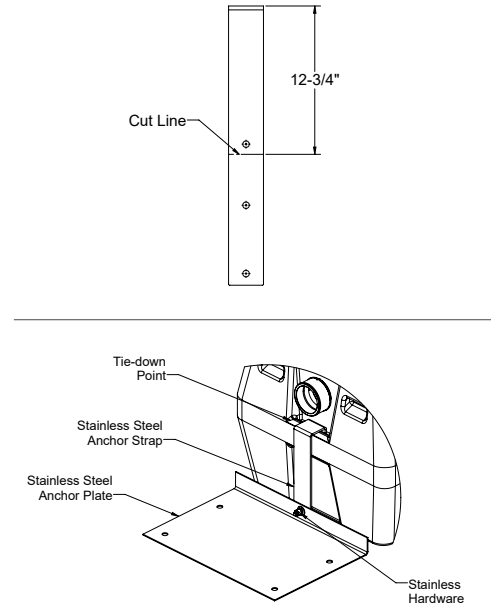

UNIT INSTALLATION

- 1 Lower and center the unit into the excavated hole. Do not use chains or accessways to move the unit.
- 2 The water table must not exceed the tank height prior to the addition of risers.
- 3 Ensure the unit cover is level with finished grade.
- 4 Install 1-1/2" PVC pipe as an extension to the removable screen to access at grade.
- 5 Fill PS-50-S with water before backfilling to stabilize the unit and prevent float out during backfilling.

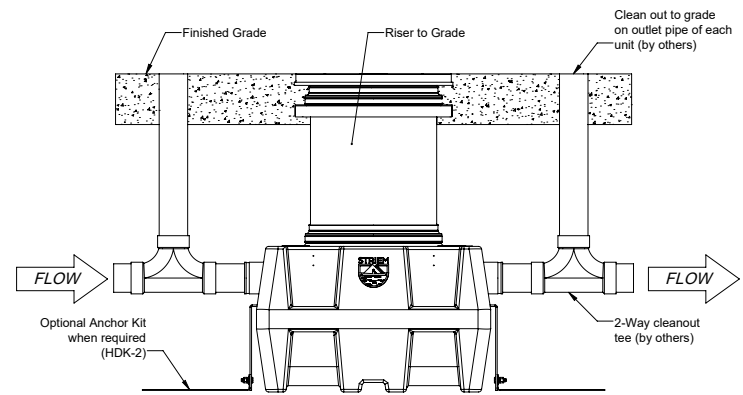

BACKFILLING & FINISHED CONCRETE SLAB

- 1 Preparation of sub grade per geotech recommendations.
- 2 Stabilize and compact sub grade to 95% proctor.
- 3 Before backfilling and pouring of slab, secure covers and risers (if used) to the unit.
- 4 Place 6" aggregate base under slab. Aggregate should be 3/4" size rock, or sand, with no fines.
- 5 Backfill using crushed aggregate material approximately 3/4" size rock, or sand, with no fines.
- 6 Thickness of concrete slab around the covers to be 8" for traffic loading. Thickness of concrete slab around the covers to be 4" for pedestrian or greenspace areas.
- 7 Concrete slab cannot interfere with the tank body below the risers.
- 8 Concrete to be 28 day compressive strength to 4000 PSI with 6 ± 1% air entrainment.
- 9 NO. 4 rebar (1/2") grade 60 steel per ASTM A615: connected with tie wire.
- 10 Rebar to be 2 1/2" from edge of concrete.
- 11 Rebar spacing 12" grid. 4" spacing around access openings.

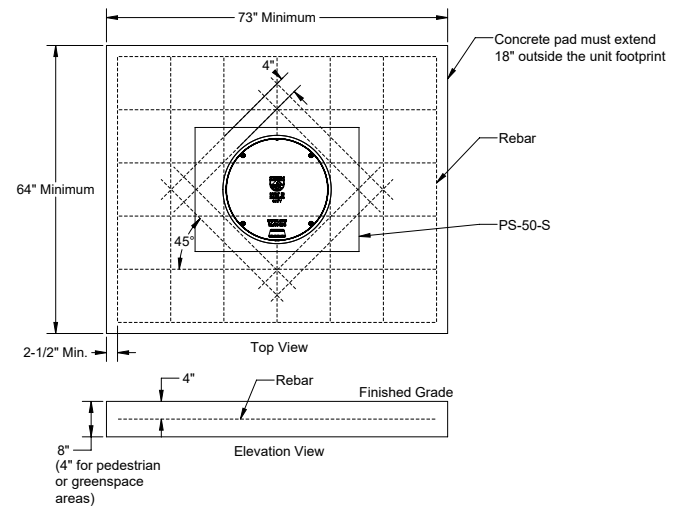

TELEGLIDE RISER | INSTALLATION INSTRUCTIONS

- 1 Place PS-50-S so that the pipe connections line up with jobsite piping. Measure dimension X to determine riser height needed. Select the required risers from the adjacent table. Riser chart shows quantity for each tank manway.

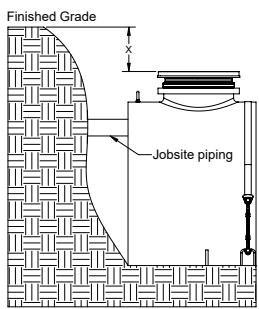

Standard Cover Adapter	
Riser Height Needed	Risers Required Per Manway
0" - 5"	None
5" - 24"	SR24 (1)
24" - 39"	LR24 (1)

- 2 Loosen upper clamp with nut driver bit (included with tank). If no risers are needed, adjust cover adapter height as needed. Ensure 2-1/2" minimum engagement is maintained. If risers are needed, remove covers from cover adapters, and cover adapters from the unit.

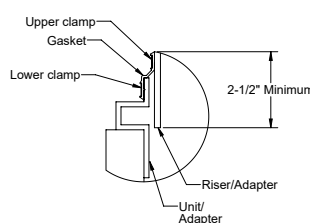

- 3 Insert cover adapters into the required risers until they stop. Tighten upper clamp to keep risers from shifting. Risers are installed from short to long. Measure the riser height needed, X + 5.25" down the sidewall of the risers. Mark the location with china marker (included with tank). Cover adapter may need to be adjusted outward for some dimension ranges. If mark is at the end of riser, no cutting is required.

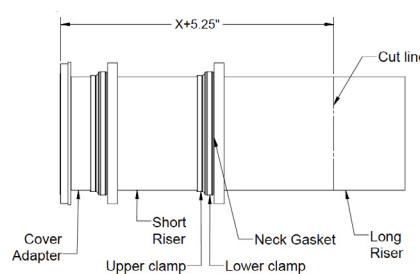

- 4 Uninstall cover adapters and risers. Extend mark made in step 3 around the circumference of the riser. Cut along line with jigsaw, circular saw, or reciprocating saw. Make a mark around the circumference of the riser 3" from the cut end of riser. If no cuts were needed, make the mark 3" from the bottom of the bottom riser.

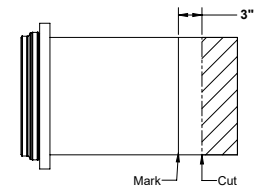

- 5 Wipe clean all riser and cover adapter sidewalls. Insert the first riser into the tank neck until the mark made in step 4 is in-line with the top of the neck gasket. This will ensure your risers reach the finished grade measured in step 1.

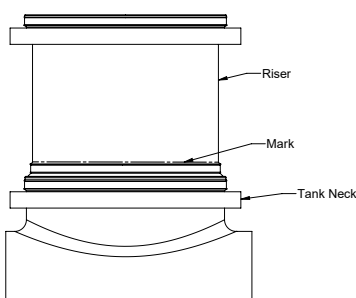

- 6 Install risers and cover adapters into the tank neck starting from the marked riser, moving up to finished grade. Upper clamps may need to be loosened or removed to aid in assembly.

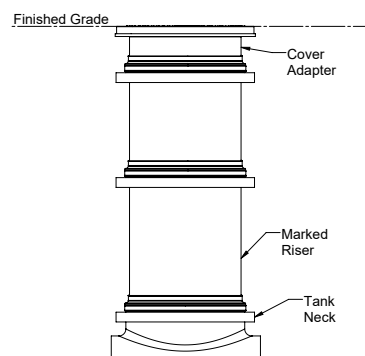

- 7 Tighten all clamps to 14 lbs. of torque. Reinstall covers on cover adapters. If tilting of the cover adapter is required to be flush with finished floor, it must be done after all clamps are tightened. A 6.5° tilt is the maximum.

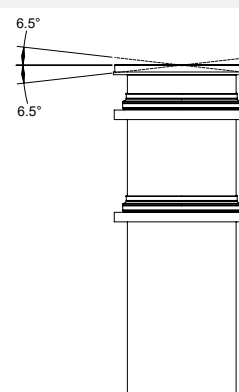

- 8 If jobsite riser height conditions change after the previous steps have been completed, there is still room for vertical adjustment. As long as the minimum engagement of 2-1/2" on all joints are maintained, the adapters and risers may be adjusted/cut as many times as necessary.

