

SPECIFICATIONS

1. 3" Plain End inlet/outlet, 2" Plain End vents standard.
2. Liquid holding capacity: 21 Gallons.
3. Unit weight: 32 lbs.
4. Maximum operating temperature 140°F continuous.

NOTES

1. For gravity drainage applications only.
2. Do not use for pressure applications.
3. Cover placement allows full access to tank for proper maintenance.
4. Diptube is removable to inspect/clean piping.

ENGINEER SPECIFICATION GUIDE

Striem neutralization tank model LB-25 shall be lifetime guaranteed and made in the USA. Tank shall be constructed of polyethylene. Tank shall be manufactured for above- or below-grade installation. Field-adjustable riser system is available as an option to bring manhole cover to grade. Tank liquid holding capacity shall be 21 gallons. Cover shall provide water/gas-tight seal and have a maximum 450 lbs. load capacity when unit is installed above-grade, and 2,500 lbs. when buried with SR16 Riser.

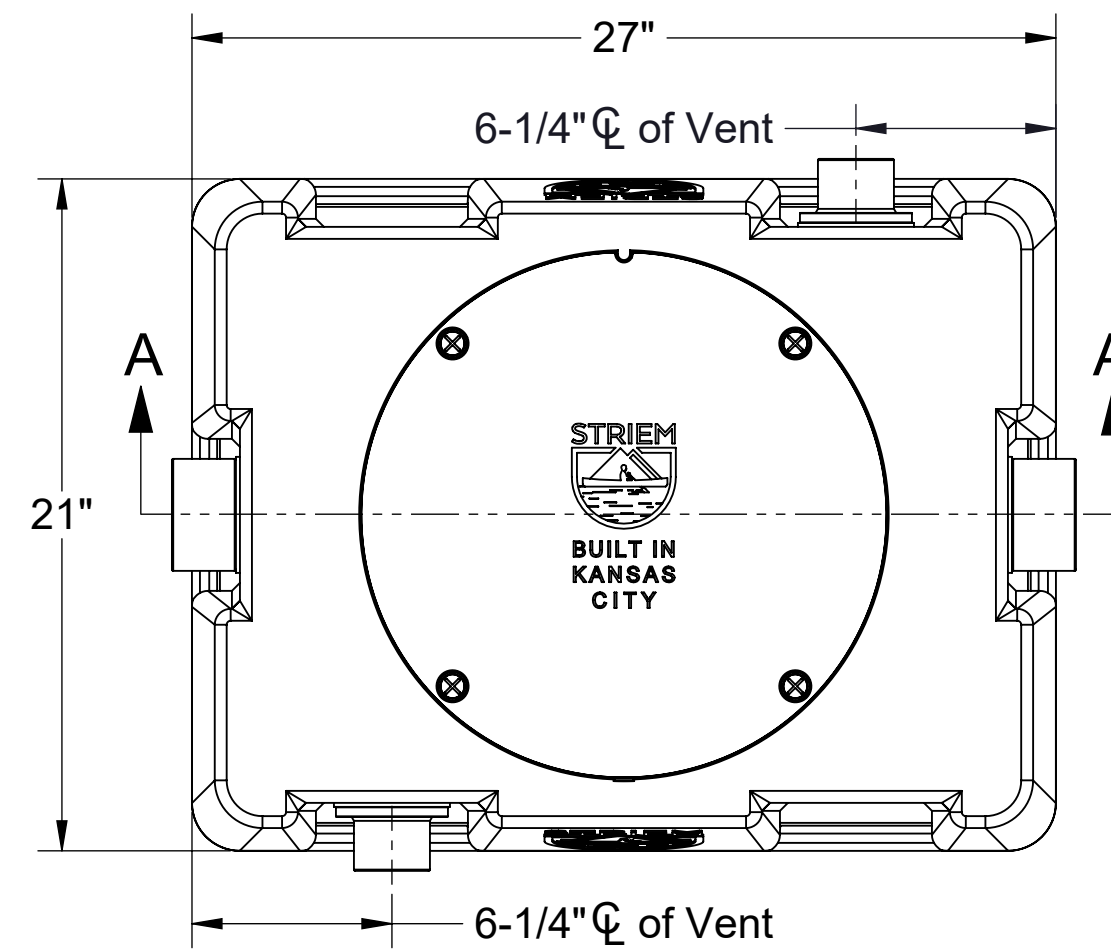

TOP VIEW

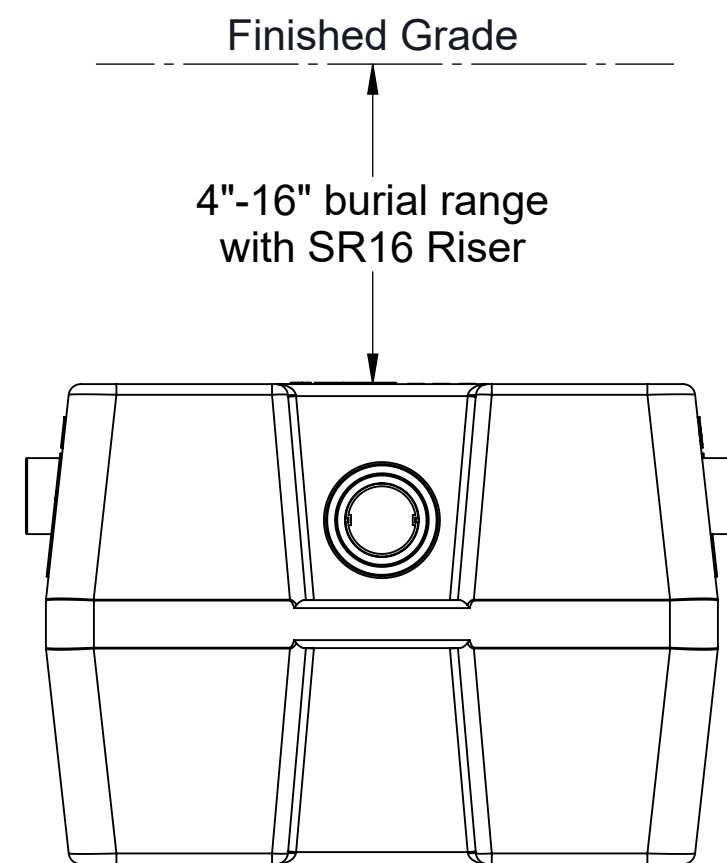

END VIEW

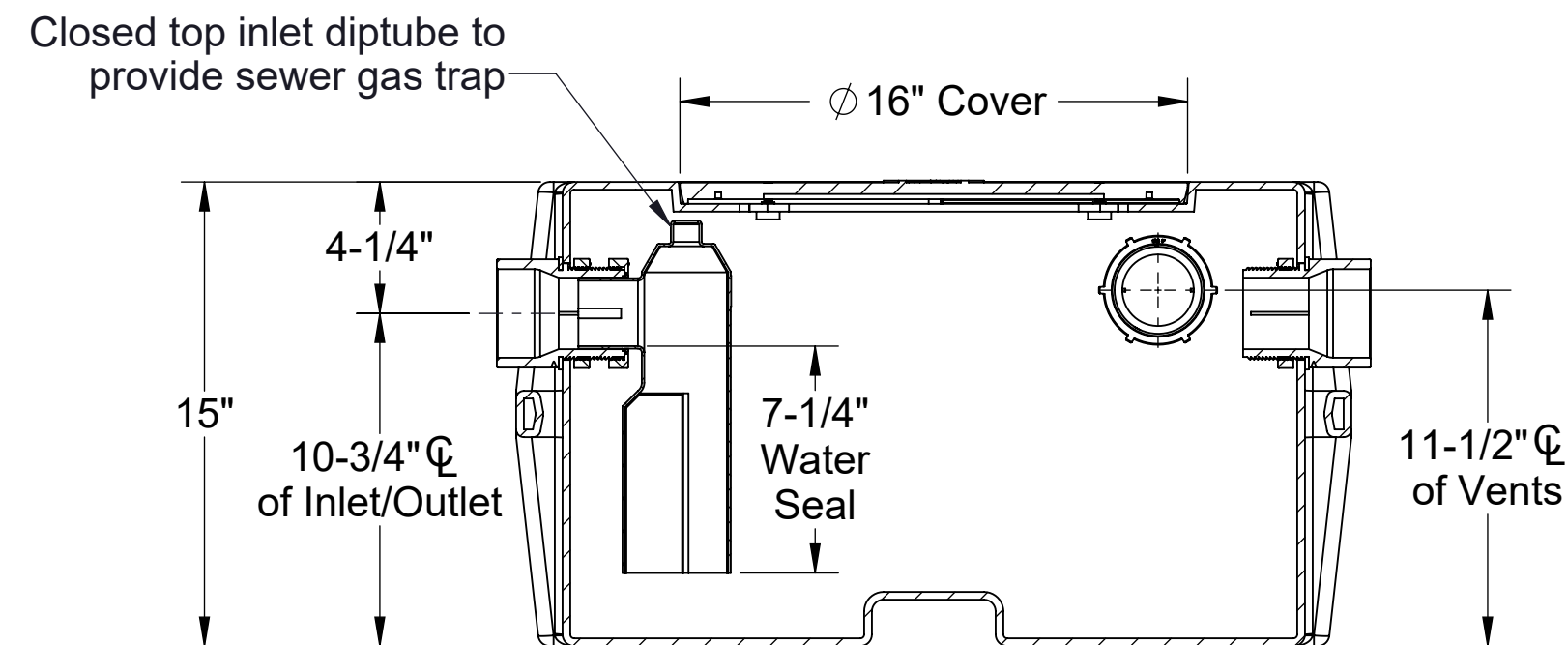

SECTION A-A

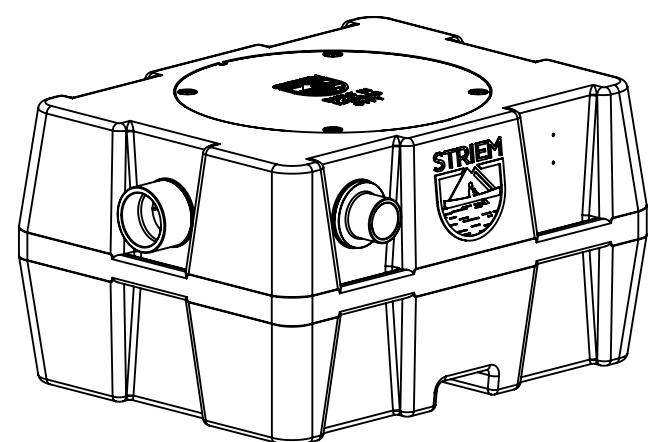

PROPRIETARY AND CONFIDENTIAL
THE INFORMATION CONTAINED IN THIS DRAWING IS THE SOLE PROPERTY OF STRIEM, LLC. ANY REPRODUCTION IN PART OR AS A WHOLE WITHOUT THE WRITTEN PERMISSION OF STRIEM, LLC. IS PROHIBITED.

OPTIONS

Connection Options (Plain End Only)

Inlet / Outlet

- 2"
- 3"

Additional Options

- SR16 Riser:** 4"-16" Burial Range
- CC-1:** Command Center pH Monitoring Package
- SPK:** Sensor Placement Kit*
- Limestone:** 90%+ Calcium Carbonate (300 lbs.)

*Required with CC-1

MODEL NUMBER:	LB-25
DESCRIPTION:	LAB BASIN™ POLYETHYLENE NEUTRALIZATION TANK
DWG BY:	ENG
DATE:	5/24/2024
REV:	0

SPECIFICATION SHEET

Striem
Kansas City, KS
Tel: 913-222-1500
orders@striemco.com
www.striemco.com

Made in the U.S.A

