

SPECIFICATIONS

1. 6" Plain End inlet/outlet shown, 3" Plain End vents standard.
2. Liquid capacity: 500 gallons (67 cu. ft.).
3. Unit weight: 800 lbs.
4. Maximum operating temperature 140°F continuous.

NOTES

1. For gravity drainage applications only.
2. Do not use for pressure applications.
3. Cover placement allows full access to tank for proper maintenance.
4. Lifting lug set for easy install.

ENGINEER SPECIFICATION GUIDE

Striem neutralization tank model LB-500 shall be lifetime guaranteed and made in the USA. Tank shall be constructed of polyethylene with 7/8" nominal wall thickness. Tank shall be manufactured for below-grade installation. Field-adjustable riser system is available as an option to bring manhole cover to grade. Tank liquid holding capacity shall be 500 gallons. Cover shall provide water/gas-tight seal and have a maximum 16,000 lbs. load capacity.

THIRD PARTY STRUCTURAL ANALYSIS

The structural design of the LB-500 has been approved and stamped by a third-party structural engineer for direct burial in accordance with Striem's installation instructions.

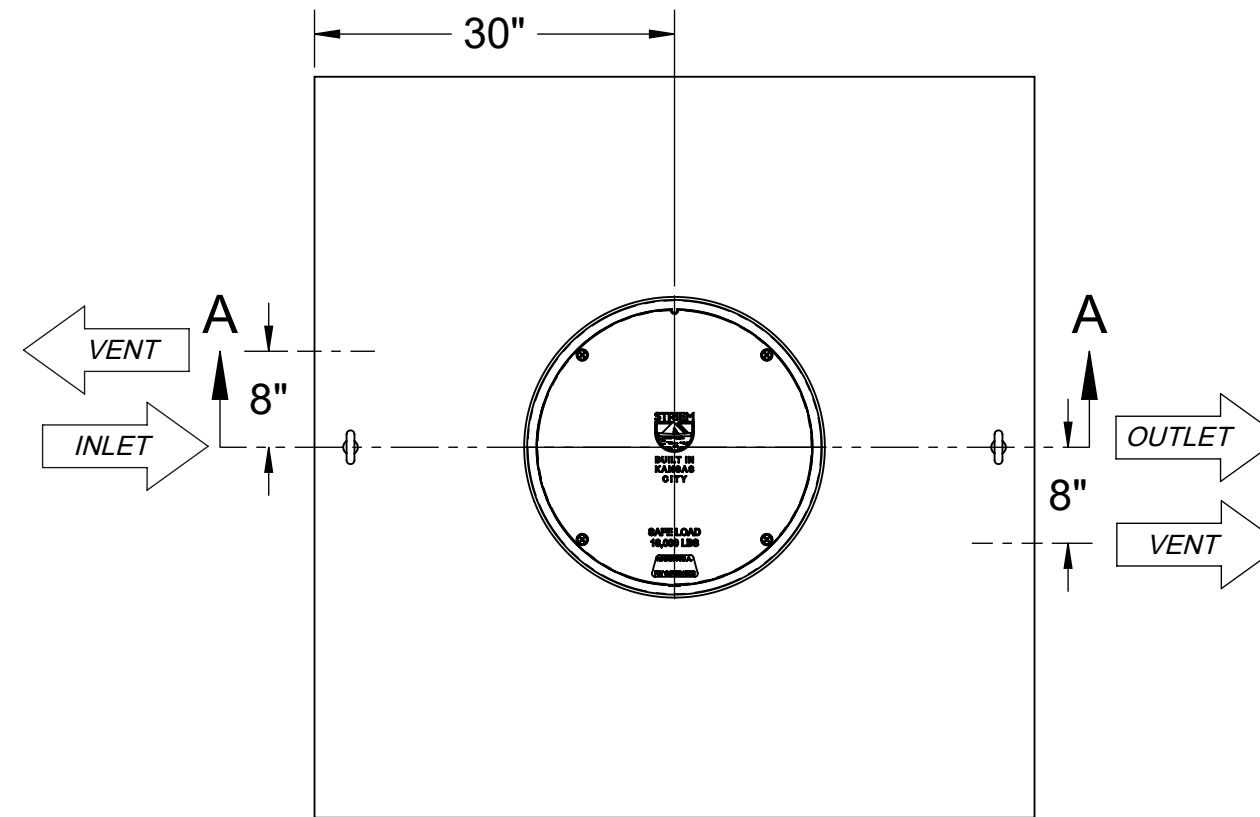

TOP VIEW

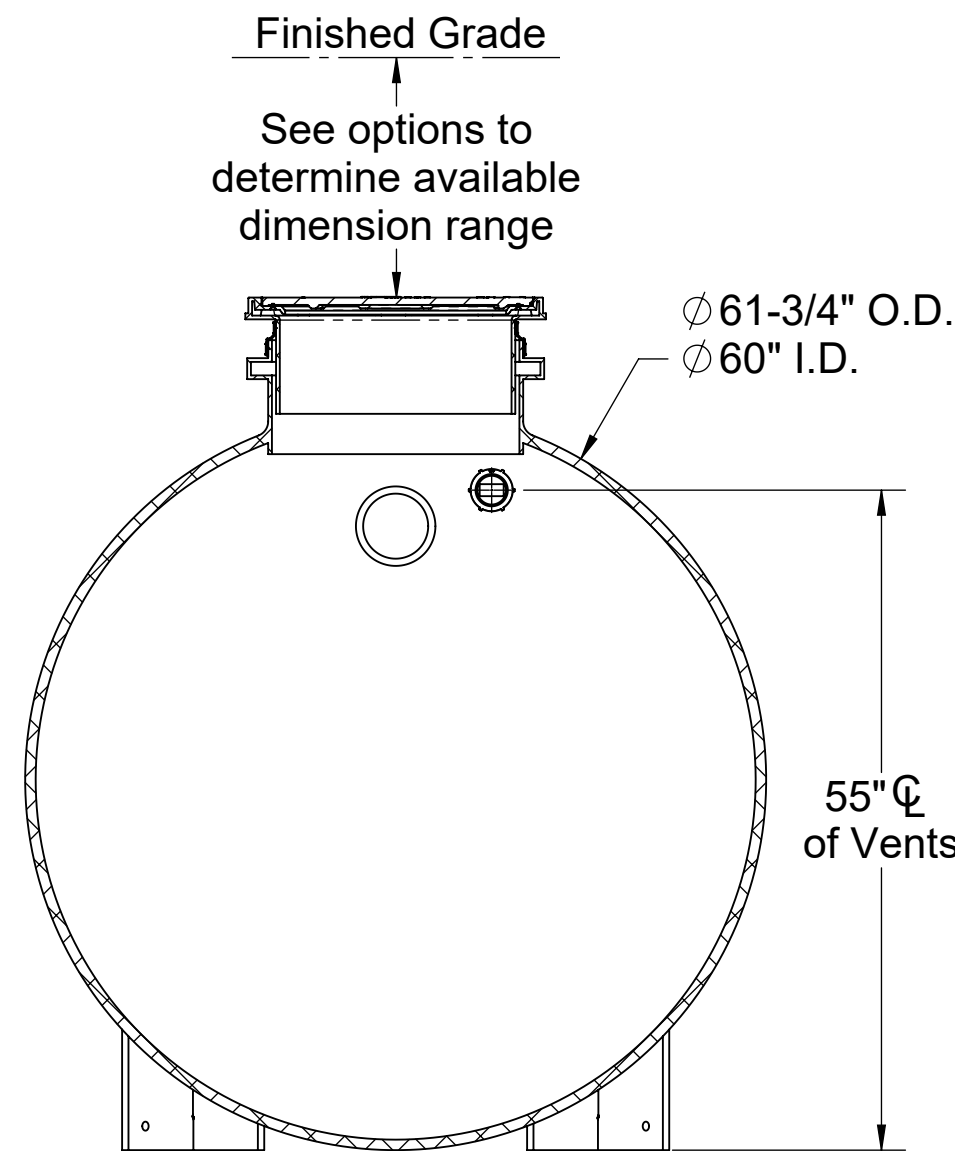

SECTION B-B

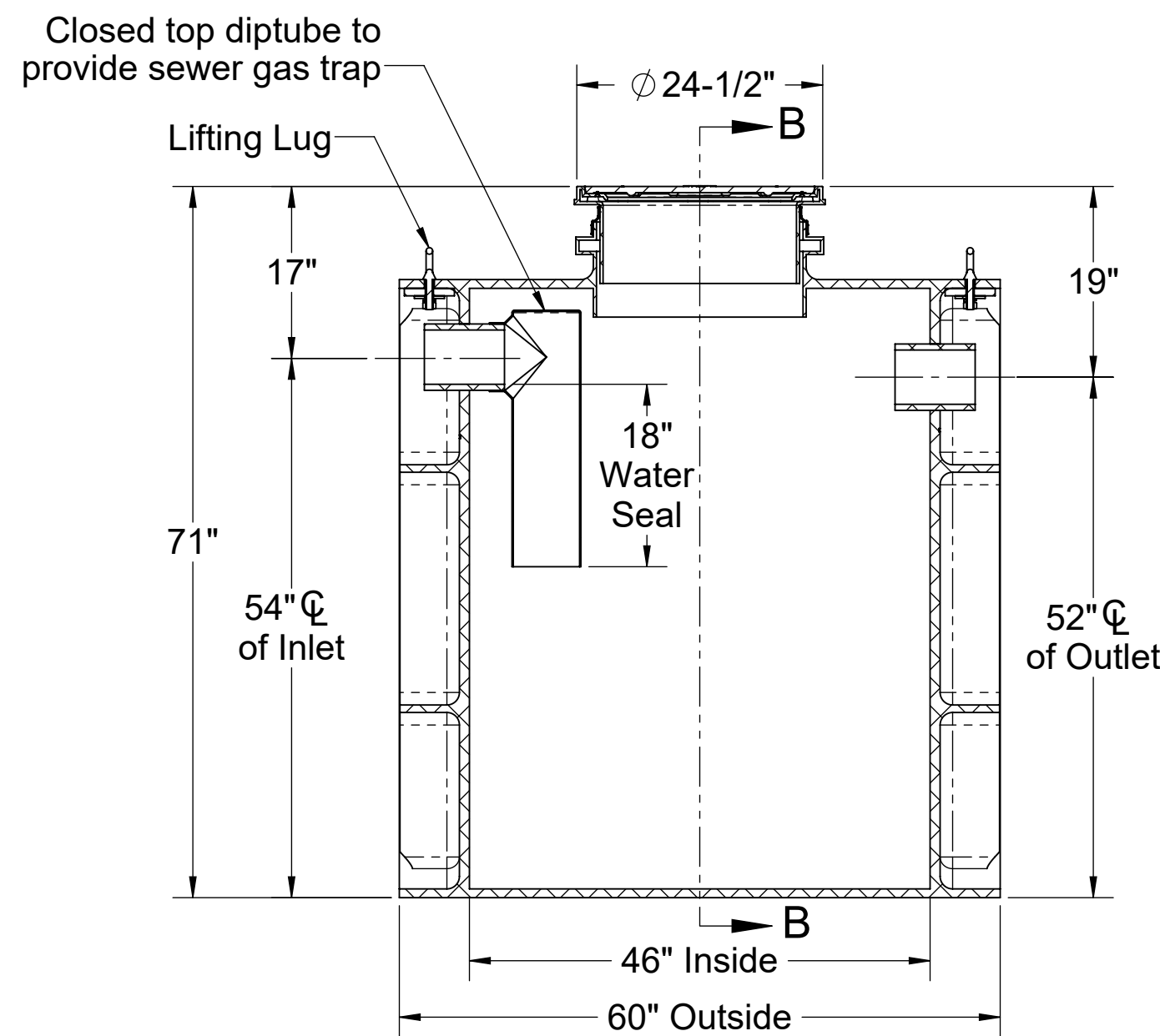

SECTION A-A

OPTIONS

Connection Options (Plain End Only)

Inlet / Outlet

- 4"
- 6"
- 8"

SELECTION
REQUIRED

Riser Options

From Factory: Up to 5"

- Up to 24": SR24
- Up to 39": LR24
- Up to 43": SR24 (2)
- Up to 58": SR24 + LR24
- Up to 72": LR24 (2)
- Up to 90": SR24 + LR24 (2)
- Up to 106": LR24 (3)

- OR -

- CPRK: 11" - 106" (See specification for more detail.)

Additional Options

- CC-1: Command Center pH Monitoring Package
- SPK: Sensor Placement Kit*
- HDK-8: High Water Table Hold Down Kit
- Limestone: 90%+ Calcium Carbonate (6,500 lbs.)

*Required with CC-1

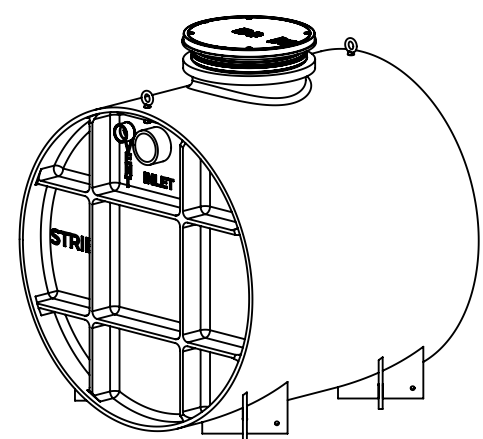

PO IS NON-CANCELABLE
ORDER IS NON-RETURNABLE

PROPRIETARY AND CONFIDENTIAL
THE INFORMATION CONTAINED IN THIS DRAWING IS THE SOLE PROPERTY OF STRIEM, LLC.
ANY REPRODUCTION IN PART OR AS A WHOLE WITHOUT THE WRITTEN PERMISSION OF STRIEM, LLC. IS PROHIBITED.

MODEL NUMBER: LB-500

DESCRIPTION:
LAB BASIN™
POLYETHYLENE NEUTRALIZATION TANK
500 GALLON CAPACITY

DWG BY: ENG **DATE:** 5/28/2024 **REV:** 1

SPECIFICATION SHEET

Striem
Kansas City, KS
Tel: 913-222-1500
orders@striemco.com
www.striemco.com

Made in the U.S.A

