

SPECIFICATIONS

1. 4" Plain End inlet/outlet shown, 3" Plain End vents standard.
2. Max flow rate: 43 GPM per 1016.3 of UPC.
3. Liquid capacity: 250 Gallons (33.4 cu ft).
4. Basket capacity: 7 Gallons.
5. Unit weight: 417 lbs.
6. (1) 28" H20 rated cast iron grate and (1) 23" H20 rated pickable cast iron cover.

NOTES

1. For gravity drainage applications only.
2. Do not use for pressure applications.
3. Cover placement allows full access to tank for proper maintenance.
4. Narrow footprint allows clearance through doorways and down stairs.

ENGINEER SPECIFICATION GUIDE

Striem sand interceptor model SI-UPC-1016 shall be lifetime guaranteed and made in the USA. Interceptor shall be constructed of polyethylene. Interceptor shall be manufactured for above- or below-grade installation. Field-adjustable riser system is available as an option to bring manhole covers to grade. Interceptor liquid holding capacity shall be 250 gallons. BCB-7 basket solids capacity shall be 7 gallons. Interceptor shall have a cast iron grate over inlet section, and pickable cast iron cover over outlet section. Each cover shall be H20 rated.

THIRD PARTY STRUCTURAL ANALYSIS

The SI-UPC-1016 has been structurally analyzed in accordance with the requirements of IBC 2012 and ASCE/SEI 7 for direct burial. The maximum burial depth and backfill material are specified in our installation instructions. The structural design has been reviewed and sealed by a professional engineer registered in the state of California. A sealed structural analysis report is available upon request.

OPTIONS

Connection Options

Inlet / Outlet

- 3"
- 4"
- 6"

SELECTION REQUIRED

Riser Options

From Factory: Up to 2"

- 5" - 24": **SR24** (2)
- Up to 39": **LR24** (2)
- Up to 43": **SR24** (4)
- Up to 58": **SR24** (2) + **LR24** (2)
- Up to 72": **LR24** (4)
- Up to 90": **SR24** (2) + **LR24** (4)

*If in the range of 2" - 5", contact Striem for a custom solution.

Additional Options

- HDK-2:** High Water Table Hold Down Kit

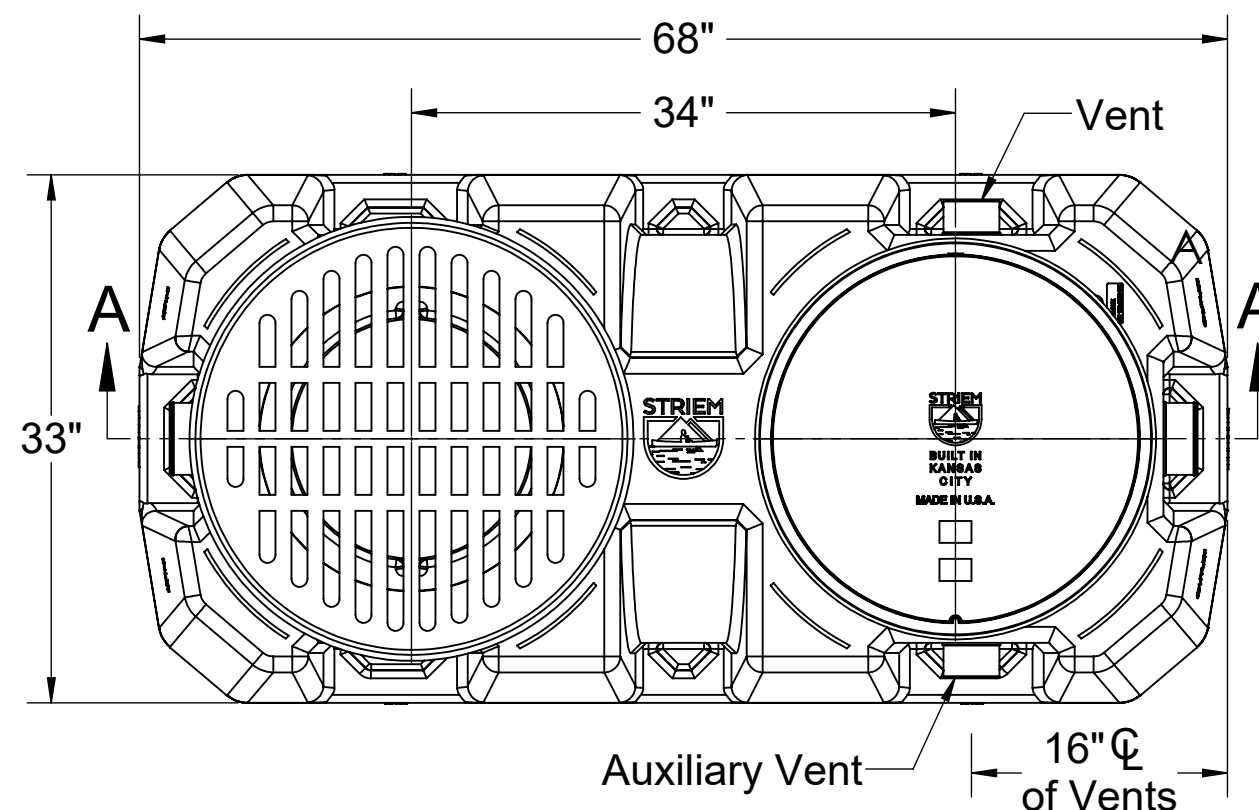

TOP VIEW

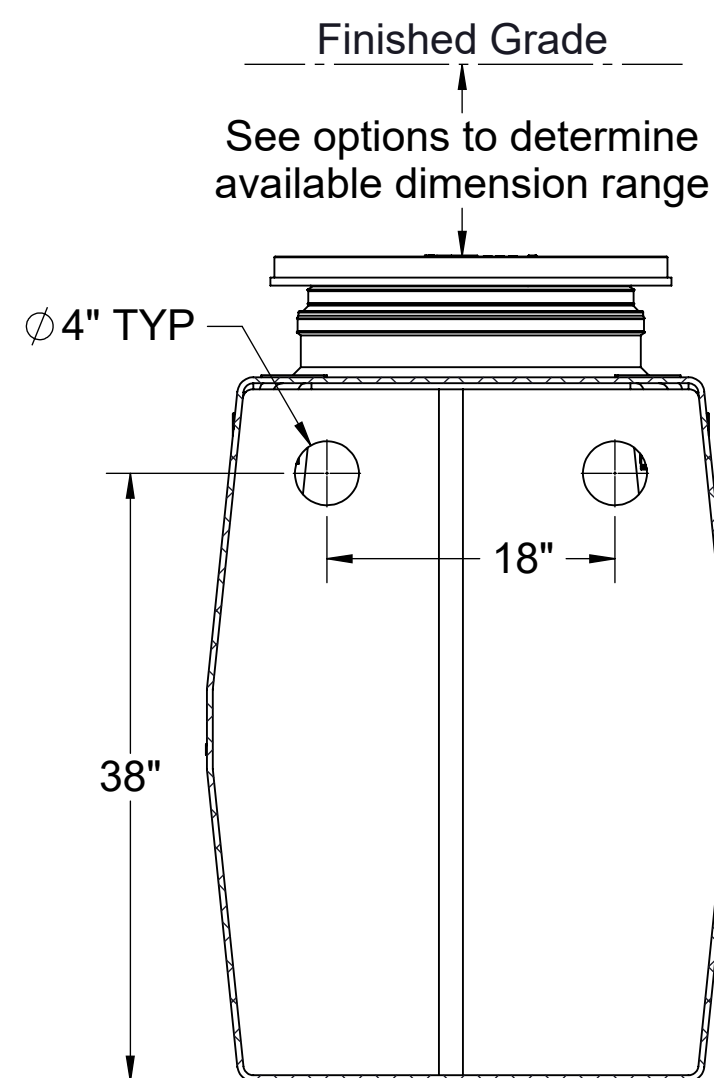

SECTION B-B

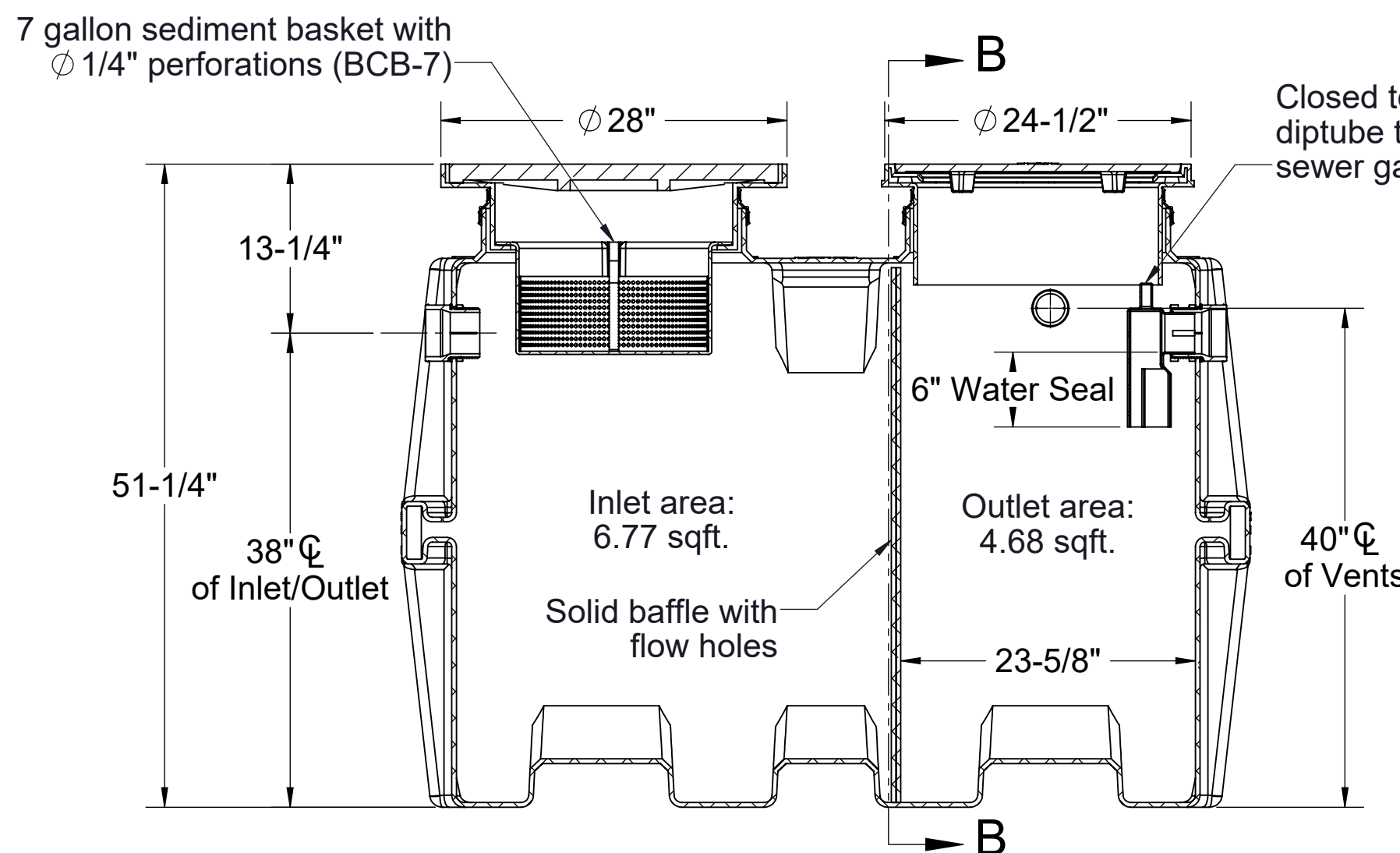

SECTION A-A

Signature: _____

Date: _____

Company: _____

Project: _____

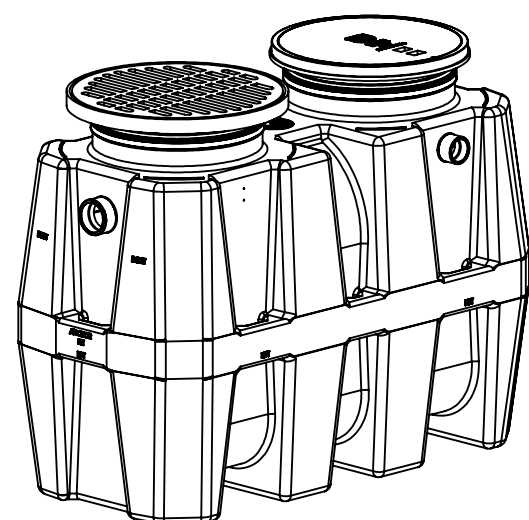

PO IS NON-CANCELABLE
ORDER IS NON-RETURNABLE

PROPRIETARY AND CONFIDENTIAL
THE INFORMATION CONTAINED IN THIS DRAWING IS THE SOLE PROPERTY OF STRIEM, LLC.
ANY REPRODUCTION IN PART OR AS A WHOLE WITHOUT THE WRITTEN PERMISSION OF STRIEM, LLC. IS PROHIBITED.

MODEL NUMBER: SI-UPC-1016

DESCRIPTION:

250 GALLON SAND INTERCEPTOR DESIGNED PER SPECIFICATIONS LISTED IN UPC 1016.0.

DWG BY: ENG

DATE: 8/29/2024

REV: 1

SPECIFICATION SHEET

Striem
Kansas City, KS
Tel: 913-222-1500
orders@striemco.com
www.striemco.com

Made in the U.S.A

