

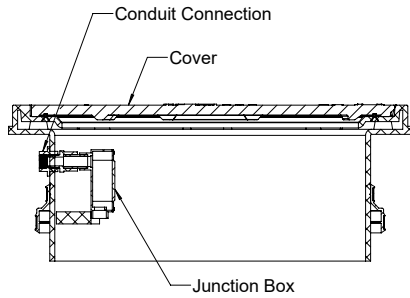

AVA-3 Liquid Level Monitoring System INSTALLATION INSTRUCTIONS

- 1 Remove unit cover where float switch will be installed. Remove the 1/2" PVC elbow fitting affixed to the junction box.



- 2
 - Cut the length of 1/2" PVC referenced in the table to be used as the extension pipe.
 - If unit will be buried with an adjusted adapter or riser extensions, add the amount the height was adjusted to ensure correct placement of float switch.

Table Length + Adjusted Height = Total length of 1/2" PVC Extension

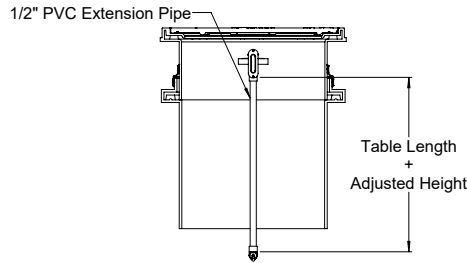

| UNIT | 1/2" PVC LENGTH |
|---------|-----------------|
| OCT-50 | 11" |
| OCT-125 | 14" |
| OCT-275 | 16" |
| BB-275 | |
| BB-500 | 25.5" |
| BB-750 | |
| BB-1500 | 27" |
| BB-1500 | 28" |
| BB-2000 | |

- 3
 - Thread the male end of the float switch onto the 1/2" female end of the elbow.
 - Glue the adapter to the extension pipe, and the extension pipe to the junction box.

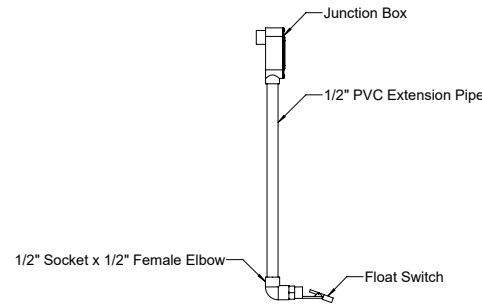

- 4
 - Run float switch wiring through the extension pipe and the bottom of the junction box.
 - Run control panel wiring through exterior conduit (by others) and tie together.
 - Installation is complete.

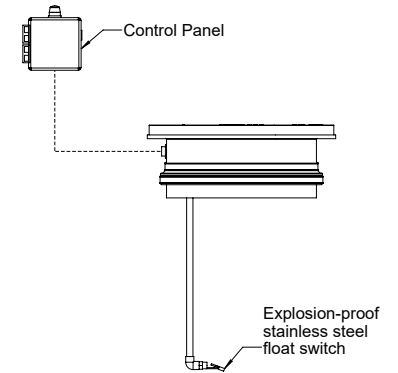

Note: "Lifetime Guarantee" shall not apply to electronic equipment provided by Striem. Electronic equipment provided by Striem shall be warranted for one year from shipment date.

913-222-1500 HELP@STRIEMCO.COM STRIEMCO.COM

CUSTOMER SERVICE HOURS: Mon-Fri, 8 am - 5 pm CST