

SPECIFICATIONS

1. 6" Plain End inlet/outlet shown, 3" Plain End vents standard.
2. Max flow rate: 314 GPM.
3. Liquid capacity: 1500 Gallons (201 cu. ft.).
4. Oil capacity: 488 Gallons.
5. Solids capacity: 825 Gallons.
6. Unit weight: 1676 lbs.
7. Maximum operating temperature 140°F continuous.
8. Slick Stick Oil Level Monitoring System (see page 2).

NOTES

1. For gravity drainage applications only.
2. Do not use for pressure applications.
3. Cover placement allows full access to tank for proper maintenance.
4. Lifting lug set for easy install.

ENGINEER SPECIFICATION GUIDE

Striem oil separator model OT-1500-SS shall be lifetime guaranteed and made in the USA. Separator shall be constructed of polyethylene with 7/8" nominal wall thickness. Separator shall be manufactured for below-grade installation. Field-adjustable riser system is available as an option to bring manhole covers to grade. Separator flow rate shall be 314 GPM. Separator liquid holding capacity shall be 1500 gallons and oil capacity shall be 488 gallons. Solids capacity shall be 825 gallons. Covers shall be H20 rated pickable cast iron. Separator shall be certified to IAPMO IGC 183-2016 and carry a UPC listing.

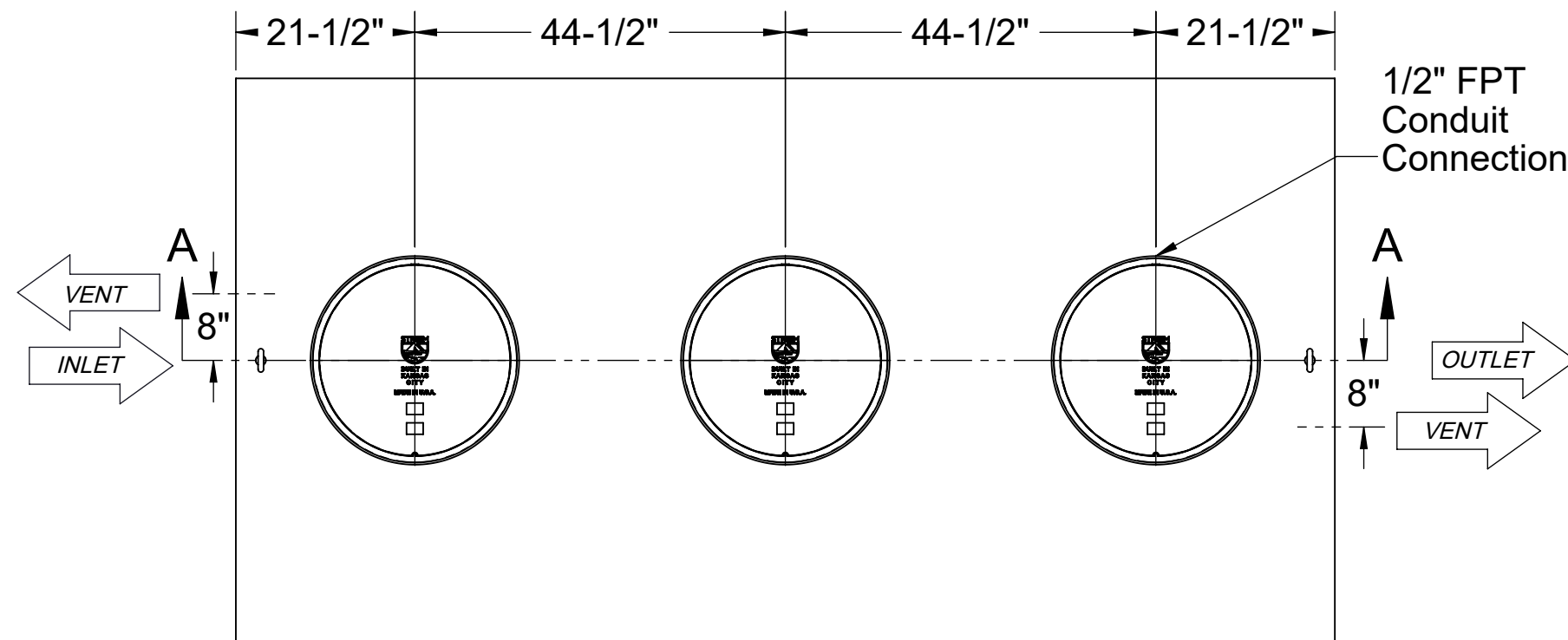

TOP VIEW

OPTIONS

Connection Options (Plain End Only)

Inlet / Outlet

- 4"
- 6"
- 8"

SELECTION REQUIRED

Riser Options

From Factory: Up to 2"

- Up to 21": **SR24** (3)
- Up to 36": **LR24** (3)
- Up to 40": **SR24** (6)
- Up to 55": **SR24** (3) + **LR24** (3)
- Up to 69": **LR24** (6)
- Up to 87": **SR24** (3) + **LR24** (6)
- Up to 103": **LR24** (9)

- OR -

- CPRK** (3): 11" - 103" (see specification for more detail.)

Additional Options

- HDK-6**: High Water Table Hold Down Kit

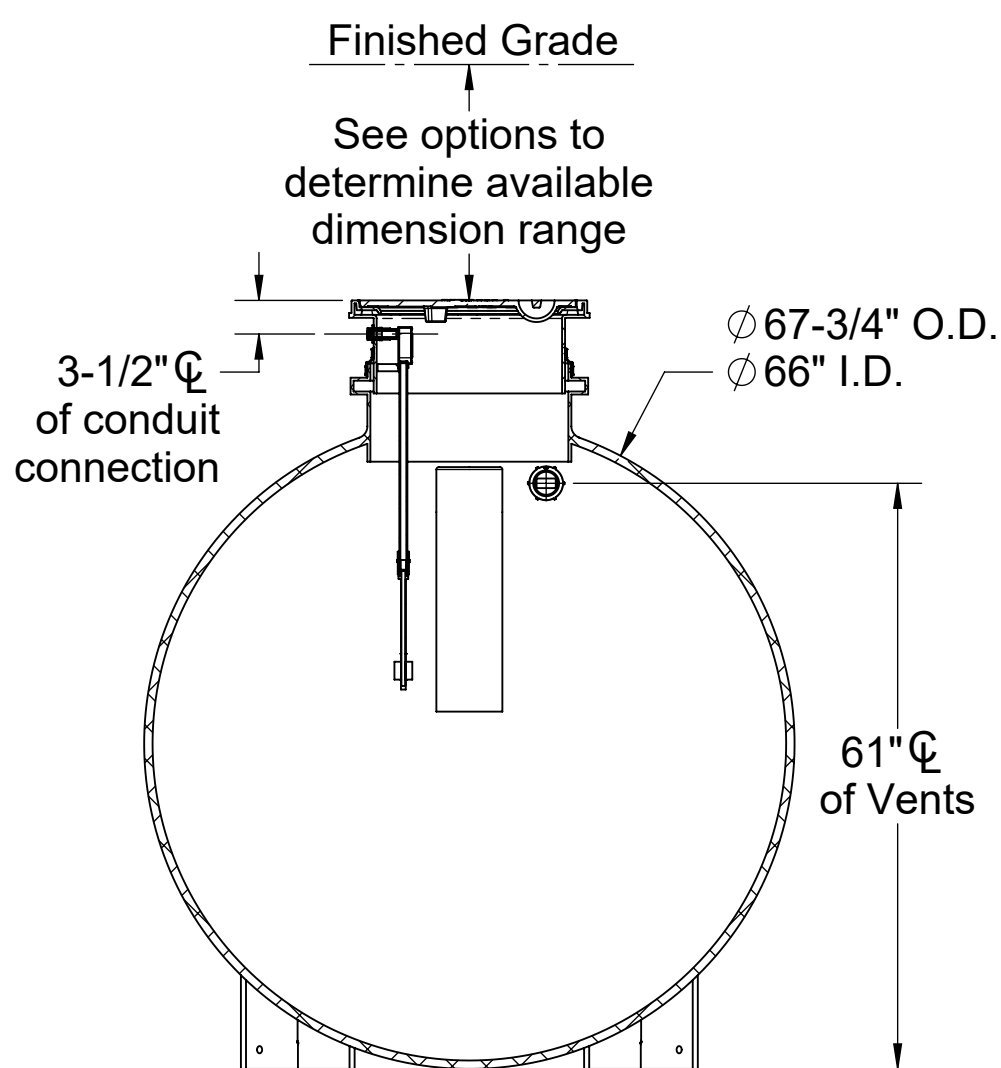

SECTION B-B

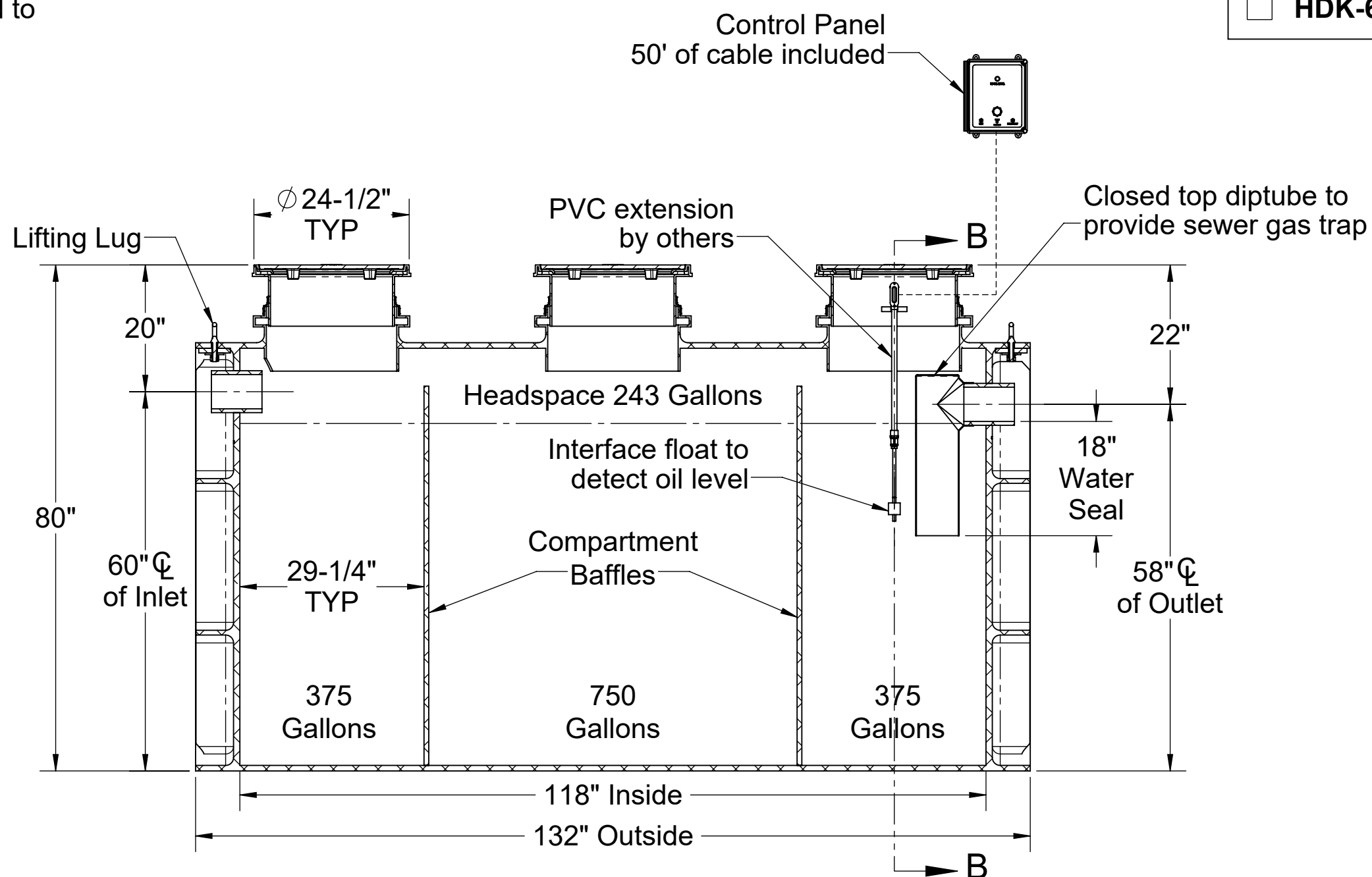

SECTION A-A

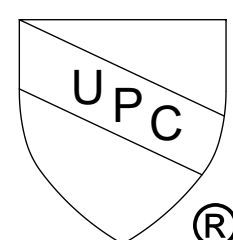
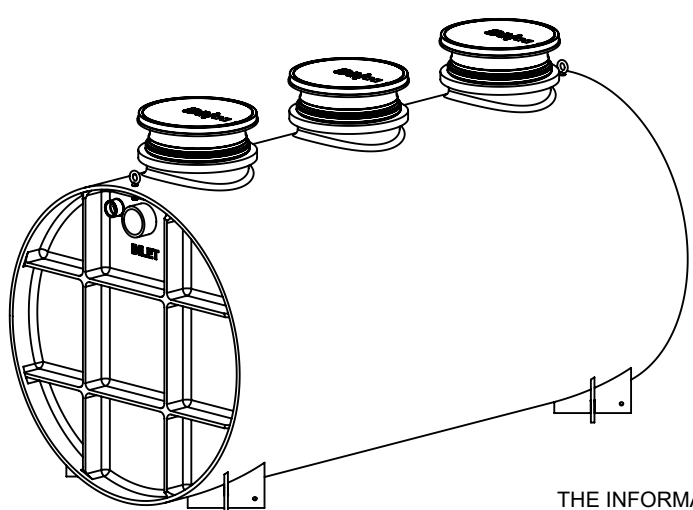

PO IS NON-CANCELABLE ORDER IS NON-RETURNABLE

PROPRIETARY AND CONFIDENTIAL

THE INFORMATION CONTAINED IN THIS DRAWING IS THE SOLE PROPERTY OF STRIEM, LLC. ANY REPRODUCTION IN PART OR AS A WHOLE WITHOUT THE WRITTEN PERMISSION OF STRIEM, LLC. IS PROHIBITED.

MODEL NUMBER: OT-1500-SS

DESCRIPTION:
OIL TANKER™
POLYETHYLENE OIL SEPARATOR WITH
SLICK STICK™ OIL LEVEL MONITORING SYSTEM
1500 GALLON CAPACITY

DWG BY: ENG **DATE:** 9/17/2024 **REV:** 1

SPECIFICATION SHEET

Striem
 Kansas City, KS
 Tel: 913-222-1500
 orders@striemco.com
 www.striemco.com

Made in the U.S.A



SPECIFICATIONS

1. UL Listed
2. Provides warning of high oil level conditions with interface float.
3. Single phase, 120 volt, 60 hertz power required.
4. NEMA 4X fiberglass, corrosion resistant, weatherproof enclosure suitable for outdoor use and damp environments.
5. Audible Alarm Buzzer, 95dB pulsing horn with no timeout.
6. High Oil Light, indicates oil has accumulated below the oil interface float or the tank liquid level is below the High Oil Interface Float.
7. Power On light inside enclosure. Visible from the outside. Green light indicates the power is on.
8. Horn off button that silences the audible alarm when pressed.
9. Test button that when pressed will test the system electronics.
10. Locking clasp on door.
11. Alarm bell stays on until reset. Light stays on until reset, even if level goes down.
12. Unit comes supplied with extra dry contact for connection to a building alarm system.

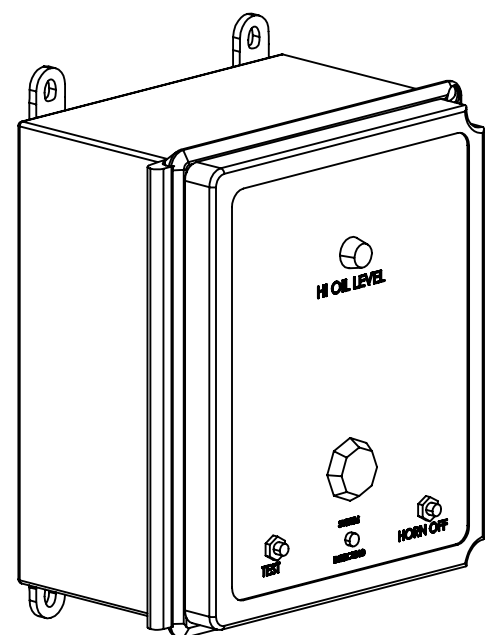
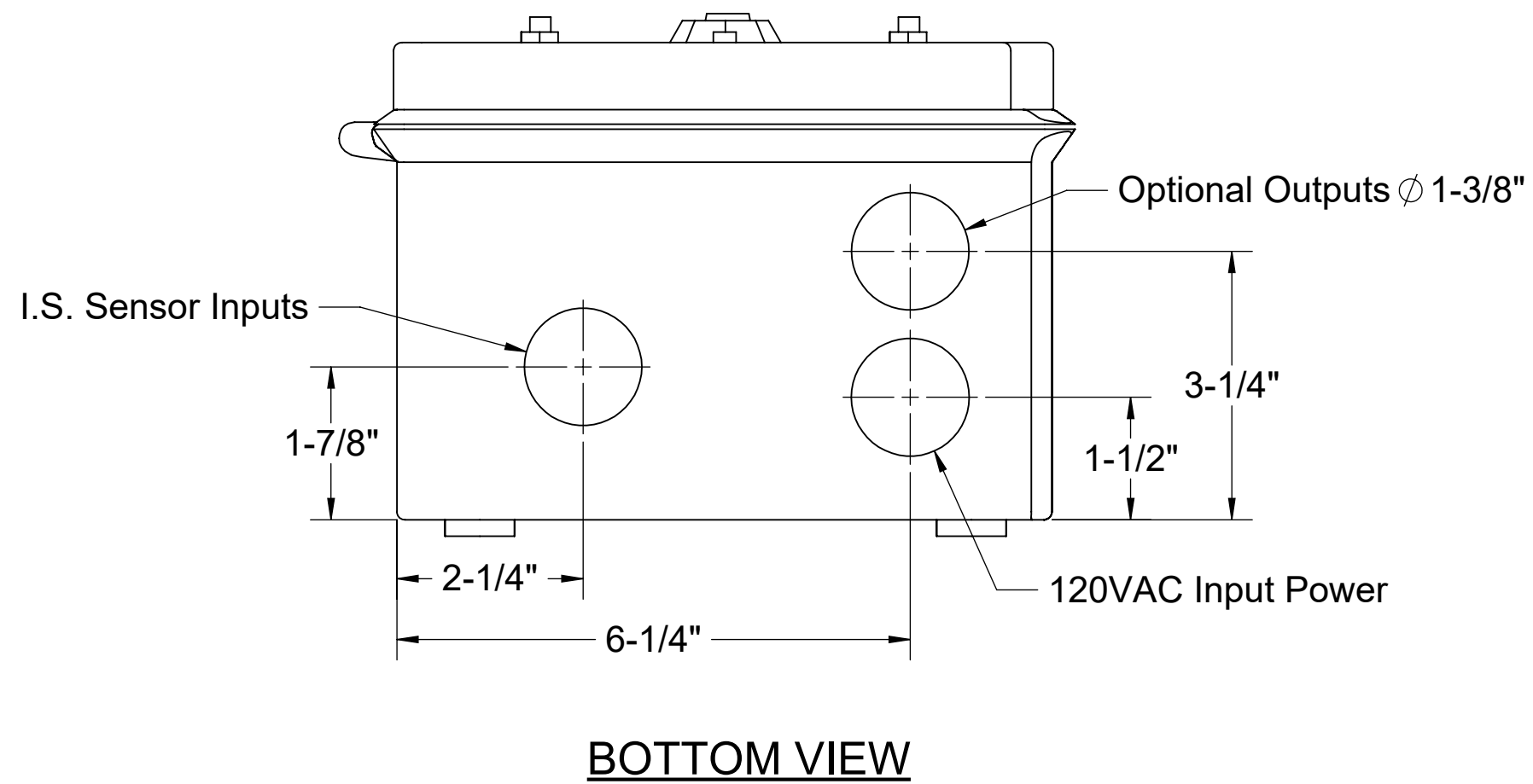
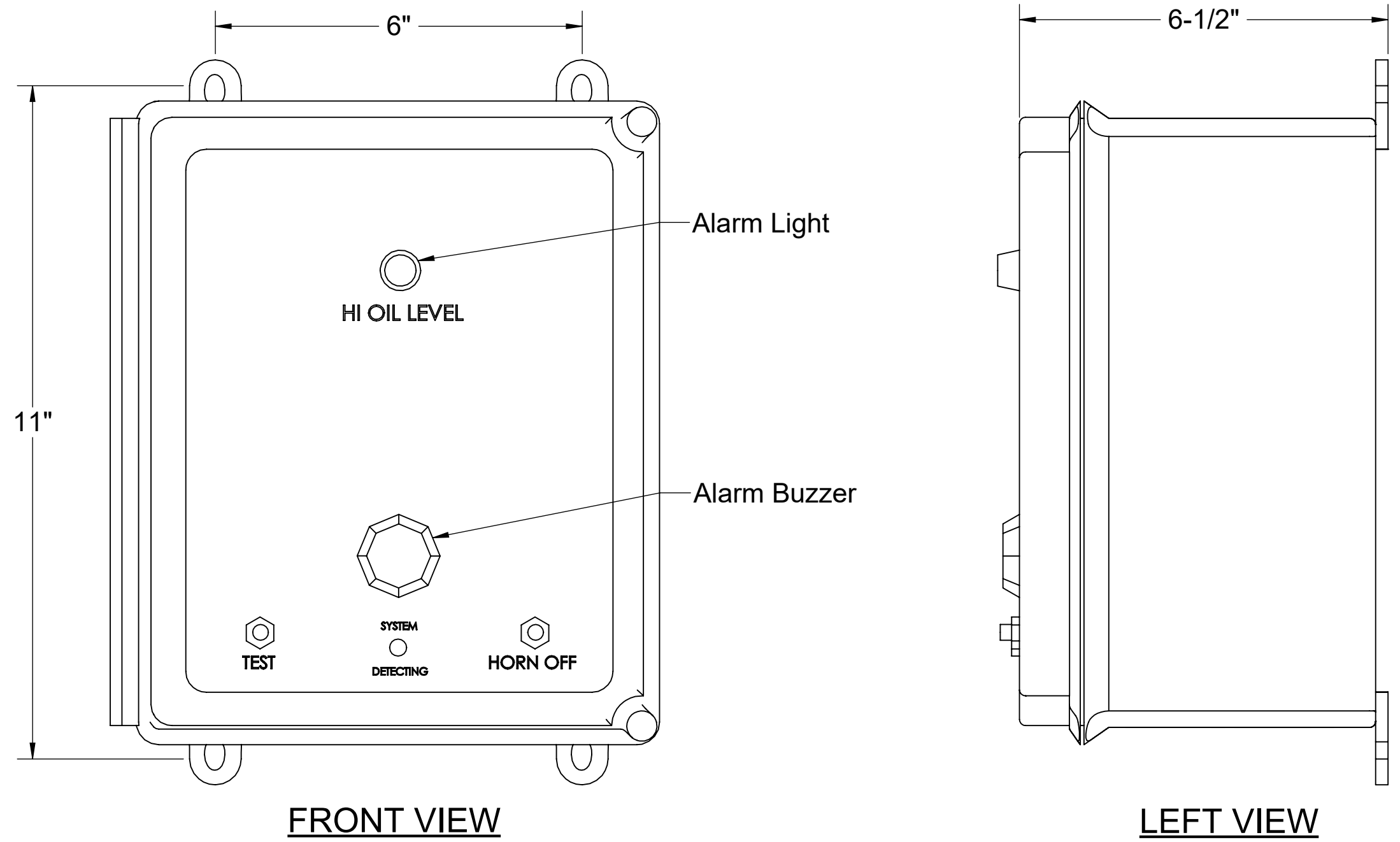
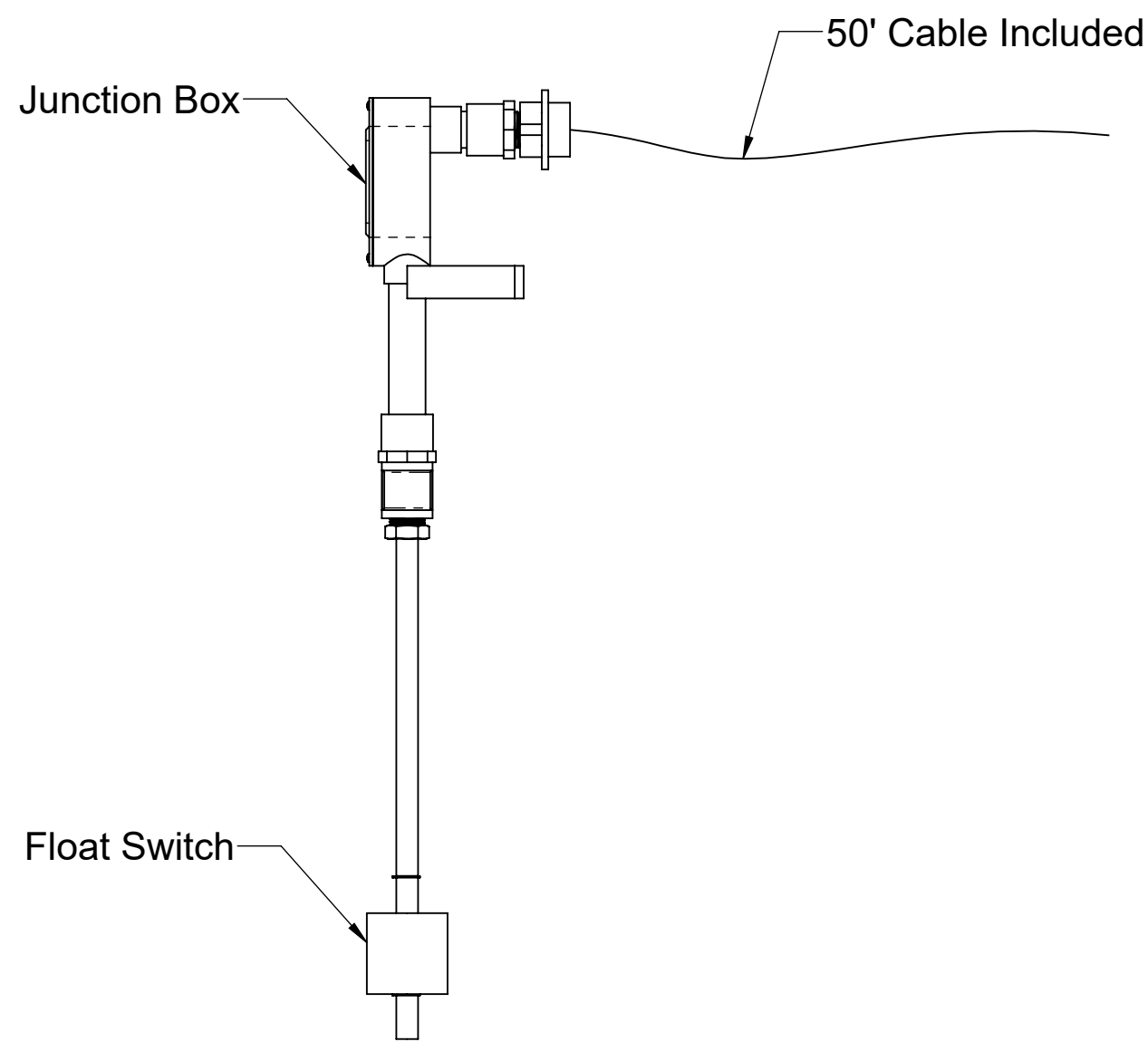

PROPRIETARY AND CONFIDENTIAL
 THE INFORMATION CONTAINED IN THIS DRAWING IS THE SOLE PROPERTY OF STRIEM, LLC.
 ANY REPRODUCTION IN PART OR AS A WHOLE WITHOUT THE WRITTEN PERMISSION OF STRIEM, LLC. IS PROHIBITED.

MODEL NUMBER: SS		SPECIFICATION SHEET	
DESCRIPTION: SLICK STICK™ OIL LEVEL MONITORING SYSTEM			
DWG BY: ENG	DATE: 5/19/2023	REV: 0	Striem Kansas City, KS Tel: 913-222-1500 orders@striemco.com www.striemco.com Made in the U.S.A