

SPECIFICATIONS

1. 2" Plain End inlet, 3" Plain End vents, C24-H cover standard.
2. Oil capacity: 110 gallons (14.7 cu ft).
3. Unit weight w/ standard cover: 120 lbs; w/ cast iron cover: 180 lbs.
4. Maximum operating temperature: 140°F continuous.

NOTES

1. For gravity drainage applications only.
2. Do not use for pressure applications.
3. Narrow footprint allows clearance through doorways and down stairs.
4. Cover placement allows full access to tank for proper maintenance.

ENGINEER SPECIFICATION GUIDE

Striem oil collection tank model OCT-125 shall be lifetime guaranteed and made in the USA. Tank shall be constructed of polyethylene. Tank shall be manufactured for above- or below-grade installation. Field-adjustable riser system is available as an option to bring manhole cover to grade. Tank oil collection capacity shall be 110 gallons. Cover shall provide water/gas-tight seal and have a maximum 16,000 lbs. load capacity.

THIRD PARTY STRUCTURAL ANALYSIS

The OCT-125 has been structurally analyzed in accordance with the requirements of IBC 2012 and ASCE/SEI 7 for direct burial. The maximum burial depth and backfill material are specified in our installation instructions. The structural design has been reviewed and sealed by a professional engineer registered in the state of California. A sealed structural analysis report is available upon request.

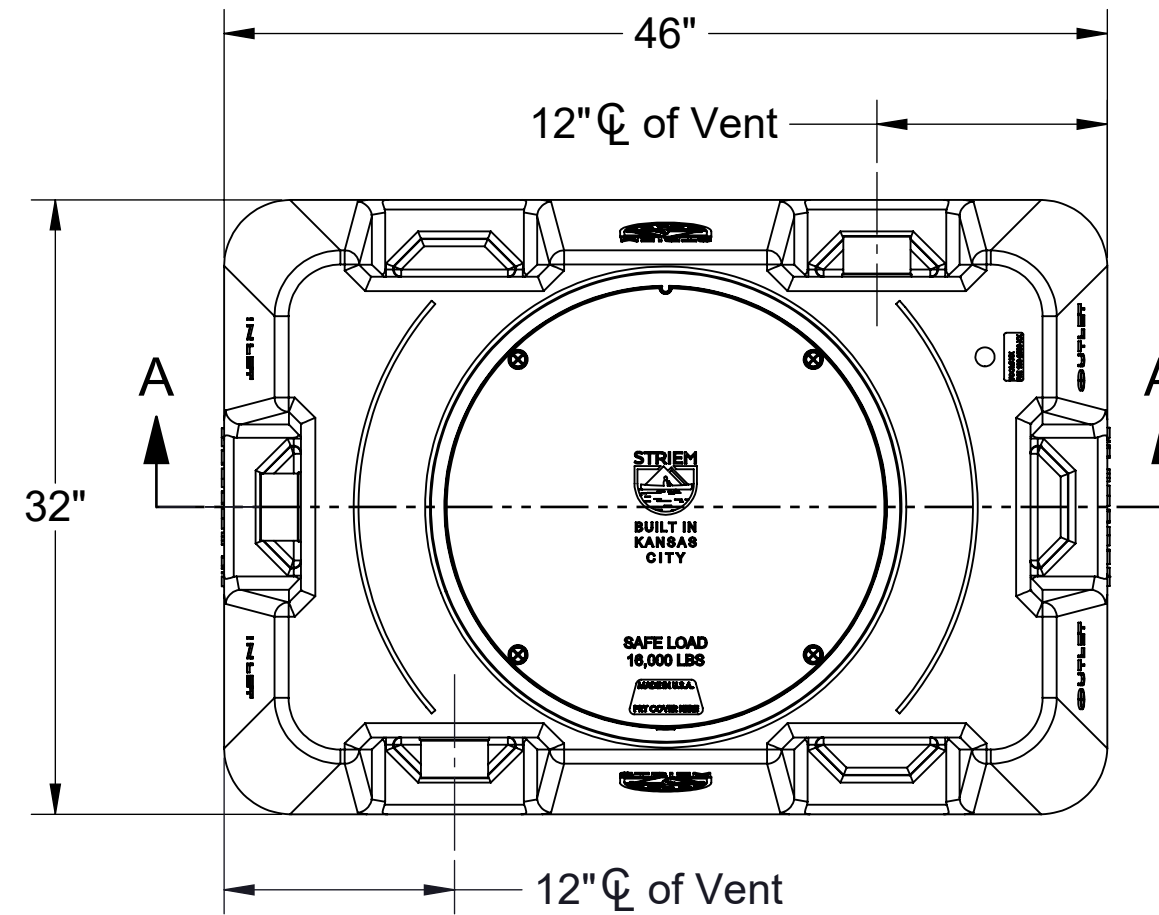

TOP VIEW

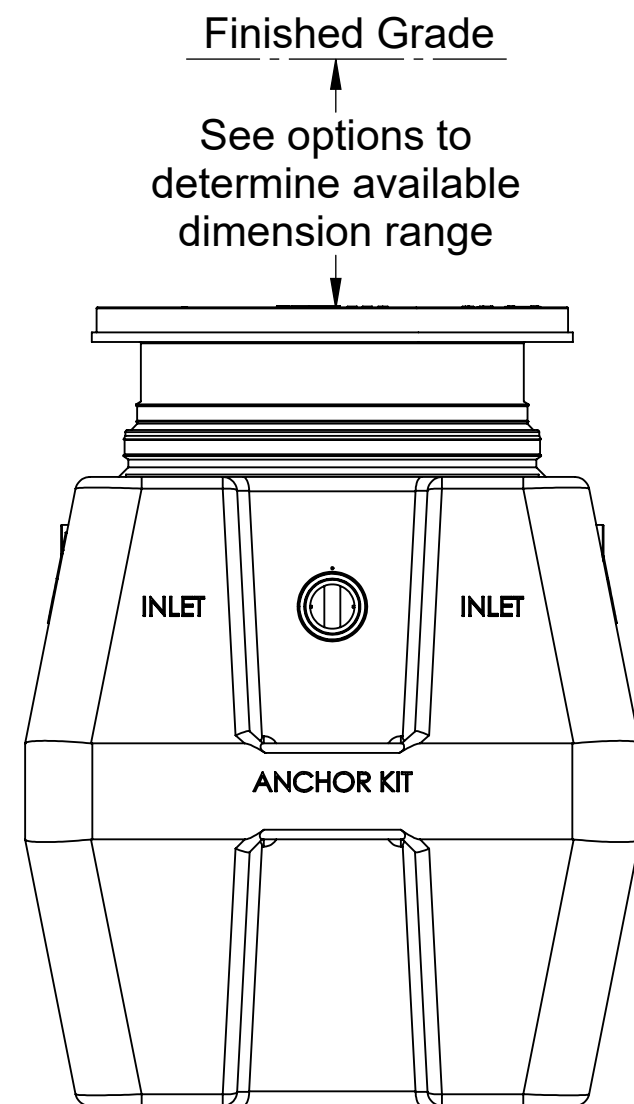

END VIEW

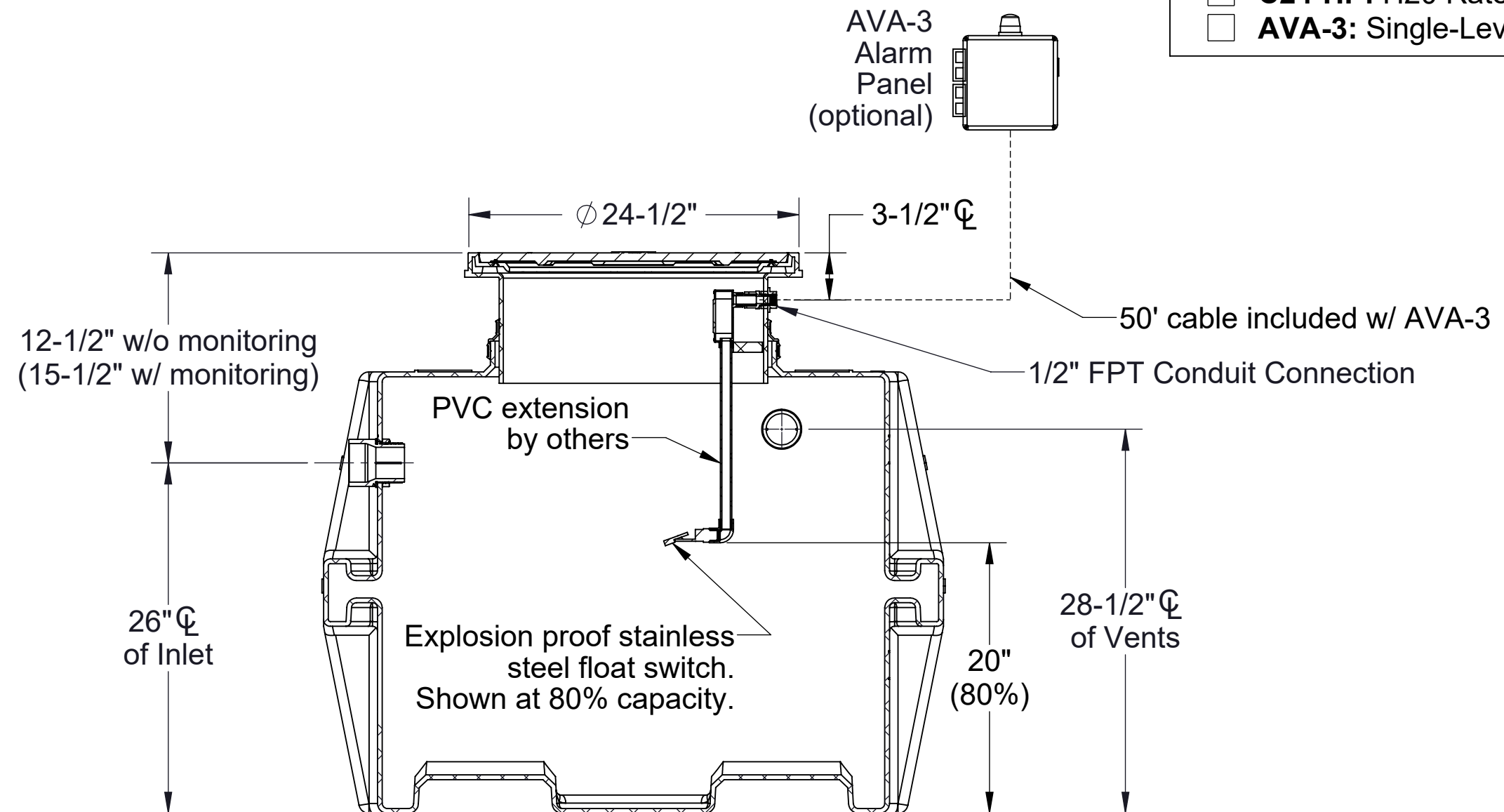

SECTION A-A

OPTIONS

Connection Options (Plain End Only)

Inlet

- 2"
- 3"
- 4"

Riser Options

From Factory: Up to 5" (Up to 2" w/ monitoring)

- Up to 24" (21" w/ monitoring): **SR24**
- Up to 39" (36" w/ monitoring): **LR24**
- Up to 43" (40" w/ monitoring): **SR24 (2)**
- Up to 58" (55" w/ monitoring): **SR24 + LR24**
- Up to 72" (69" w/ monitoring): **LR24 (2)**

- OR -

- CPRK:** 11" - 72" (11" - 69" w/ monitoring)
(See specification for more detail.)

Additional Options

- HDK-2:** High Water Table Hold Down Kit
- C24-HP:** H2O Rated Pickable Cast Iron Cover
- AVA-3:** Single-Level Monitoring Package

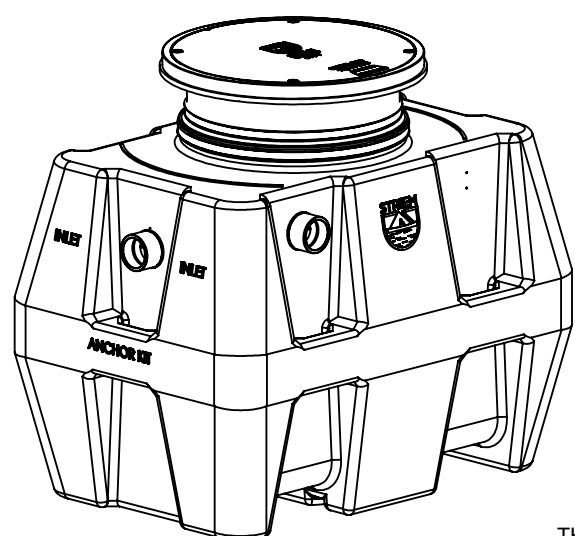

PROPRIETARY AND CONFIDENTIAL
THE INFORMATION CONTAINED IN THIS DRAWING IS THE SOLE PROPERTY OF STRIEM, LLC.
ANY REPRODUCTION IN PART OR AS A WHOLE WITHOUT THE WRITTEN PERMISSION OF STRIEM, LLC. IS PROHIBITED.

MODEL NUMBER: OCT-125

DESCRIPTION:
125 GALLON POLYETHYLENE OIL COLLECTION TANK

DWG BY: ENG **DATE:** 1/12/2024 **REV:** 2

SPECIFICATION SHEET

Striem
Kansas City, KS
Tel: 913-222-1500
orders@striemco.com
www.striemco.com

Made in the U.S.A

