

SPECIFICATIONS

1. 4" Plain End inlet/outlet standard.
2. Unit weight: 25 lbs.
3. Maximum operating temperature 140°F continuous.

NOTES

1. For above- or below-grade installation of the CC-1 Command Center pH probe.
2. For gravity drainage applications only.
3. Do not use for pressure applications.
4. Handle may be extended using 1-1/2" PVC pipe by others.
5. pH probe with 10' of wire & control panel with 50' of wire included with CC-1.

OPTIONS

Connection Options (Plain End Only)

Inlet / Outlet

- 4"
- 6"

Riser Options

From Factory: Up to 2"

- Up to 21": **SR24**
- Up to 36": **LR24**
- Up to 40": **SR24 (2)**
- Up to 55": **SR24 + LR24**
- Up to 69": **LR24 (2)**
- Up to 87": **SR24 + LR24 (2)**
- Up to 103": **LR24 (3)**

- OR -

- CPRK: 11" - 103"** (See specification for more detail.)

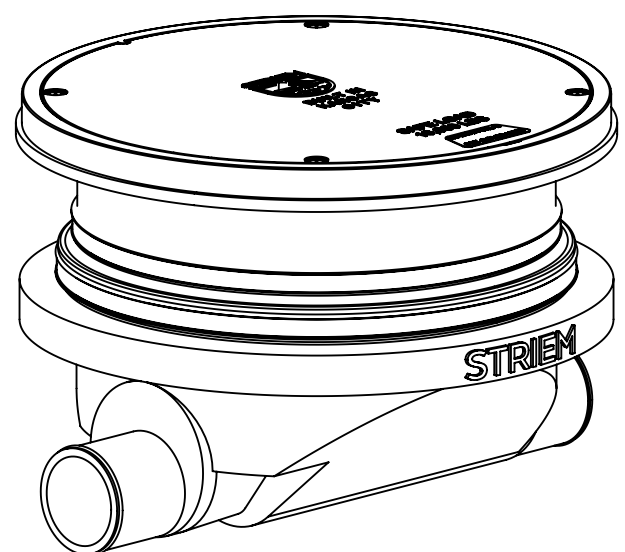
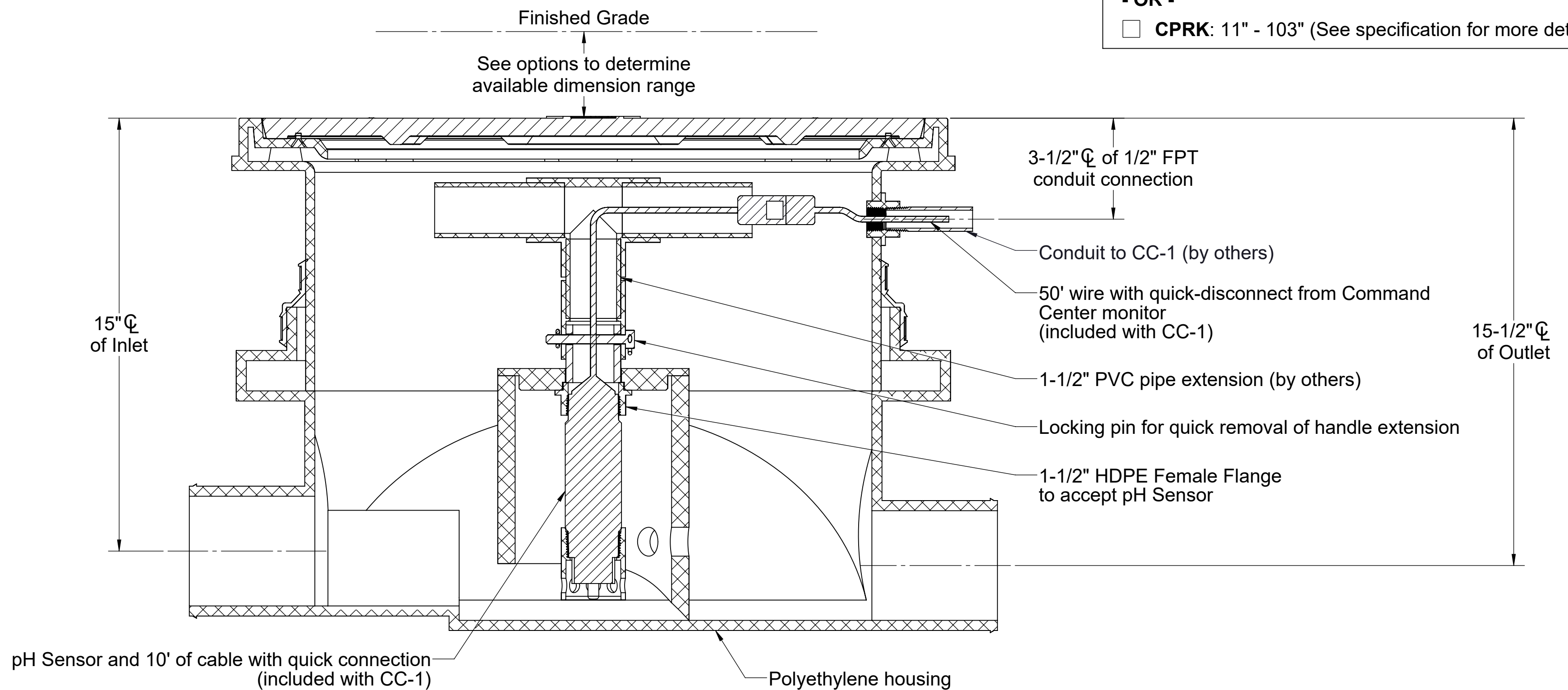

MODEL NUMBER: SPK

DESCRIPTION:
 SENSOR PLACEMENT KIT FOR
 COMMAND CENTER pH MONITORING SYSTEM

DWG BY: ENG **DATE:** 11/14/2024 **REV:** 0

SPECIFICATION SHEET

Striem
 Kansas City, KS
 Tel: 913-222-1500
 orders@striemco.com
 www.striemco.com

Made in the U.S.A

