

SPECIFICATIONS

1. 4" Plain End inlet/outlet, 3" Plain End vents, C24-H covers standard.
2. Certified max flow rate: 100 GPM.
3. Liquid capacity: 250 Gallons (33.4 cu. ft.).
4. Oil capacity: 62.5 Gallons.
5. Solids capacity: 95 Gallons.
6. Unit weight w/ standard covers: 225 lbs.; w/ cast iron covers: 345 lbs.
7. Maximum operating temperature 140°F continuous.

NOTES

1. Engineered inlet diffuser efficiently separates oil from water.
2. Capped auxiliary vent provided to allow flexibility with vent piping and design. Provided cap can be moved to unused vent location, or discarded if two chamber vents are required per local code.
3. For gravity drainage applications only.
4. Do not use for pressure applications.
5. Cover placement allows full access to tank for proper maintenance.
6. Maximum burial depth: 90" from standard cover height.

ENGINEER SPECIFICATION GUIDE

Striem high efficiency oil/water separator model OS-100 shall be lifetime guaranteed and made in the USA. Separator shall be certified to IAPMO IGC 325 and carry a UPC listing. Separator shall be constructed of polyethylene. Separator shall be manufactured for above- or below-grade installation. Field-adjustable riser system is available as an option to bring manhole covers to grade. Separator flow rate shall be 100 GPM. Separator liquid holding capacity shall be 250 gallons and oil capacity shall be 62.5 gallons. Solids capacity shall be 95 gallons. Covers shall provide water/gas-tight seal and have a maximum 16,000 lbs. load capacity.

IAPMO IGC 325 CERTIFICATION

The OS-100 has been third party certified by IAPMO to the IGC 325 standard. The OS-100 achieved an average 99% efficiency rating at 100 GPM up to the maximum oil capacity of 62.5 gallons. The structural design has been approved and stamped by a licensed structural engineer for direct burial in accordance with Striem's installation instructions.

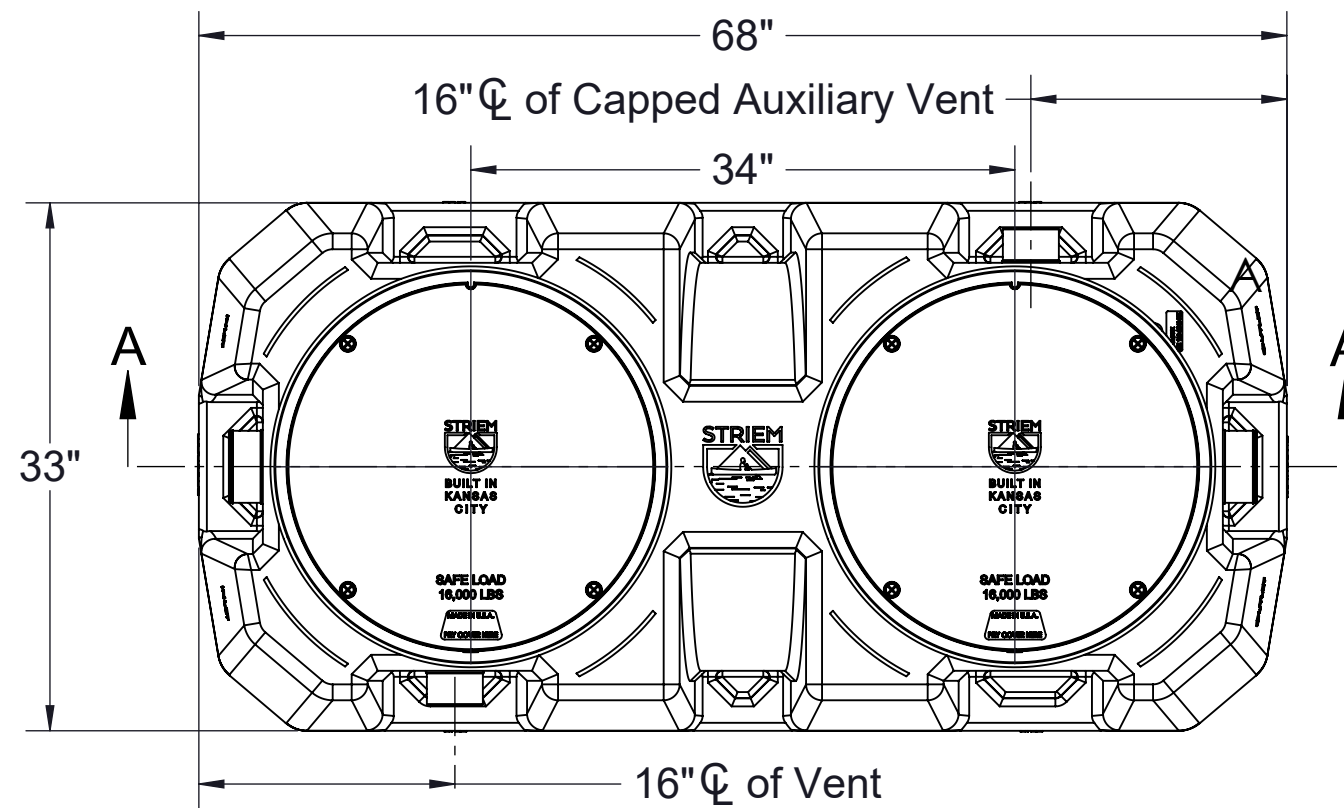

TOP VIEW

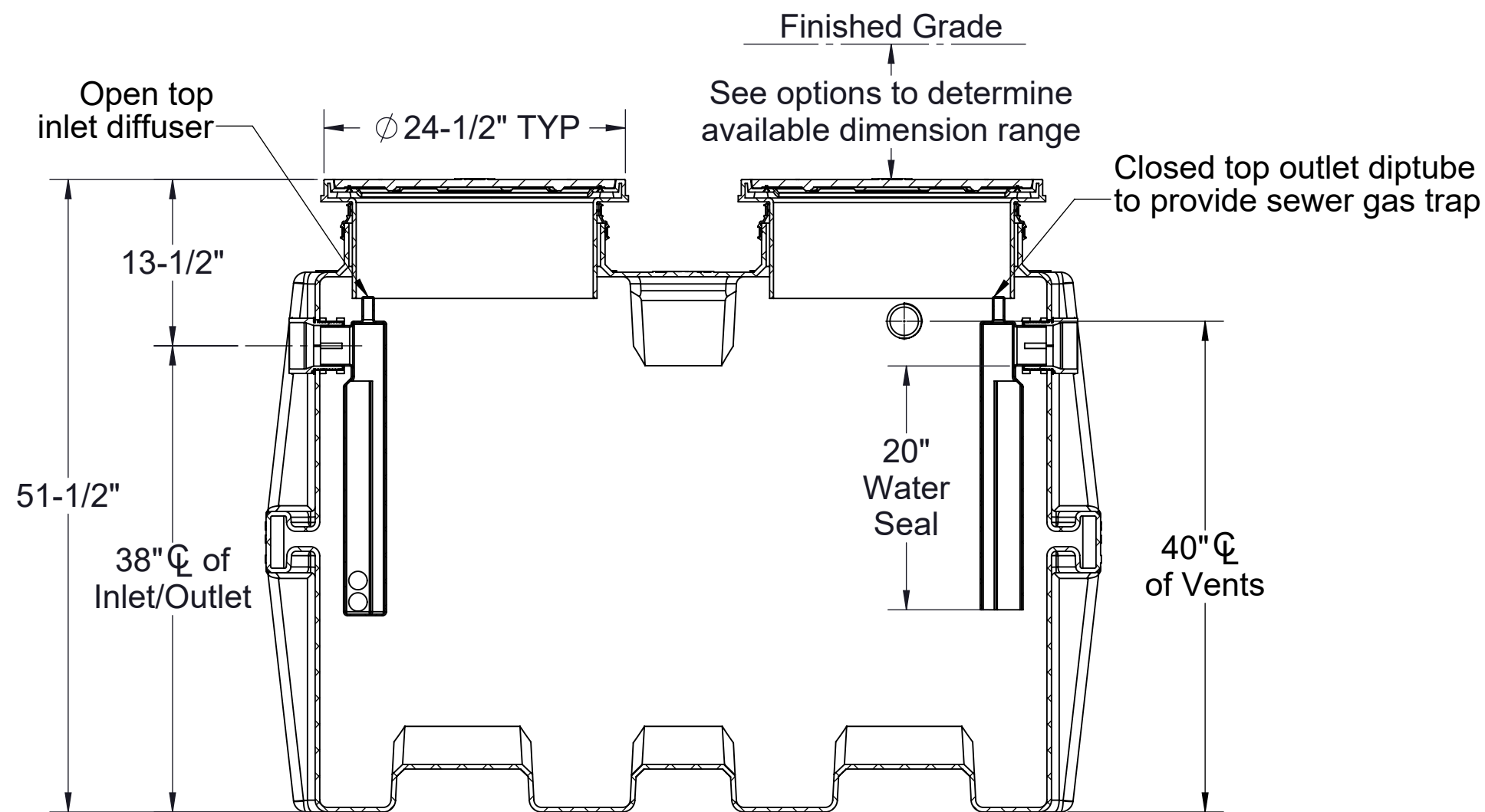

SECTION A-A

OPTIONS

Connection Options (Plain End Only)

Inlet / Outlet

- 4"
- 6"

Riser Options

From Factory: Up to 5"

- Up to 24": **SR24** (2)
- Up to 39": **LR24** (2)
- Up to 43": **SR24** (4)
- Up to 58": **SR24** (2) + **LR24** (2)
- Up to 72": **LR24** (4)
- Up to 90": **SR24** (2) + **LR24** (4)

-OR-

- CPRK** (2): 11" - 90" (See specification for more detail.)

Additional Options

- HDK-2**: High Water Table Hold Down Kit
- C24-HP** (2): H2O Rated Pickable Cast Iron Covers
- SS**: Slick Stick™ Oil Level Monitoring System*

*Monitoring system will raise covers by 3".

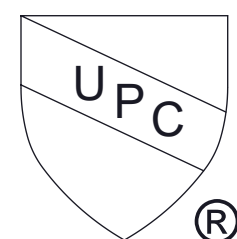
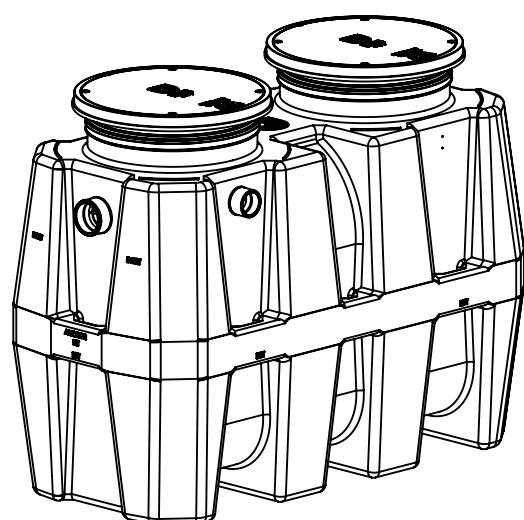

MODEL NUMBER: OS-100

DESCRIPTION:

100 GPM POLYETHYLENE
HIGH EFFICIENCY OIL/WATER SEPARATOR

DWG BY: ENG

DATE: 12/30/2024

REV: 2

SPECIFICATION SHEET

Striem
Kansas City, KS
Tel: 913-222-1500
orders@striemco.com
www.striemco.com

Made in the U.S.A

