

**SPECIFICATIONS**

1. 4" Plain End inlet/outlet standard.
2. Unit weight: 25 lbs.
3. Maximum operating temperature 140°F continuous.

**NOTES**

1. For above- or below-grade installation of the CC-1 Command Center pH probe.
2. For gravity drainage applications only.
3. Do not use for pressure applications.
4. Handle may be extended using 1-1/2" PVC pipe by others.
5. pH probe with 10' of wire & control panel with 50' of wire included with CC-1.
6. Maximum burial depth: 103" from standard cover height.

**OPTIONS**

**Connection Options (Plain End Only)**

**Inlet / Outlet**

- 4"
- 6"

**Riser Options**

**From Factory: Up to 2"**

- Up to 21": **SR24**
- Up to 36": **LR24**
- Up to 40": **SR24 (2)**
- Up to 55": **SR24 + LR24**
- Up to 69": **LR24 (2)**
- Up to 87": **SR24 + LR24 (2)**
- Up to 103": **LR24 (3)**

**- OR -**

- CPRK: 11" - 103"** (See specification for more detail.)

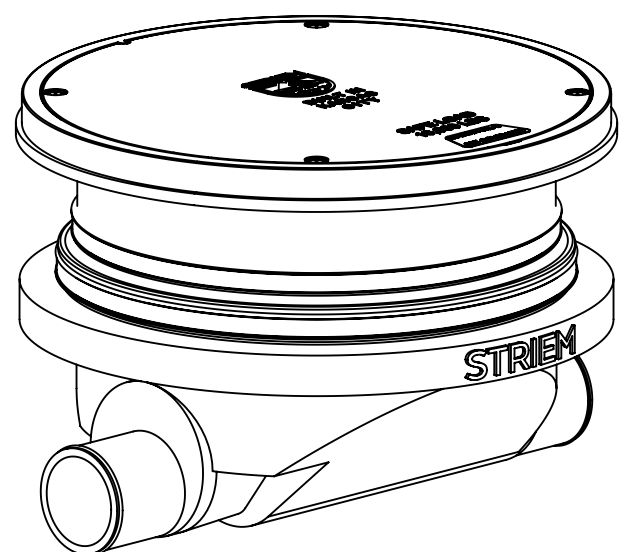
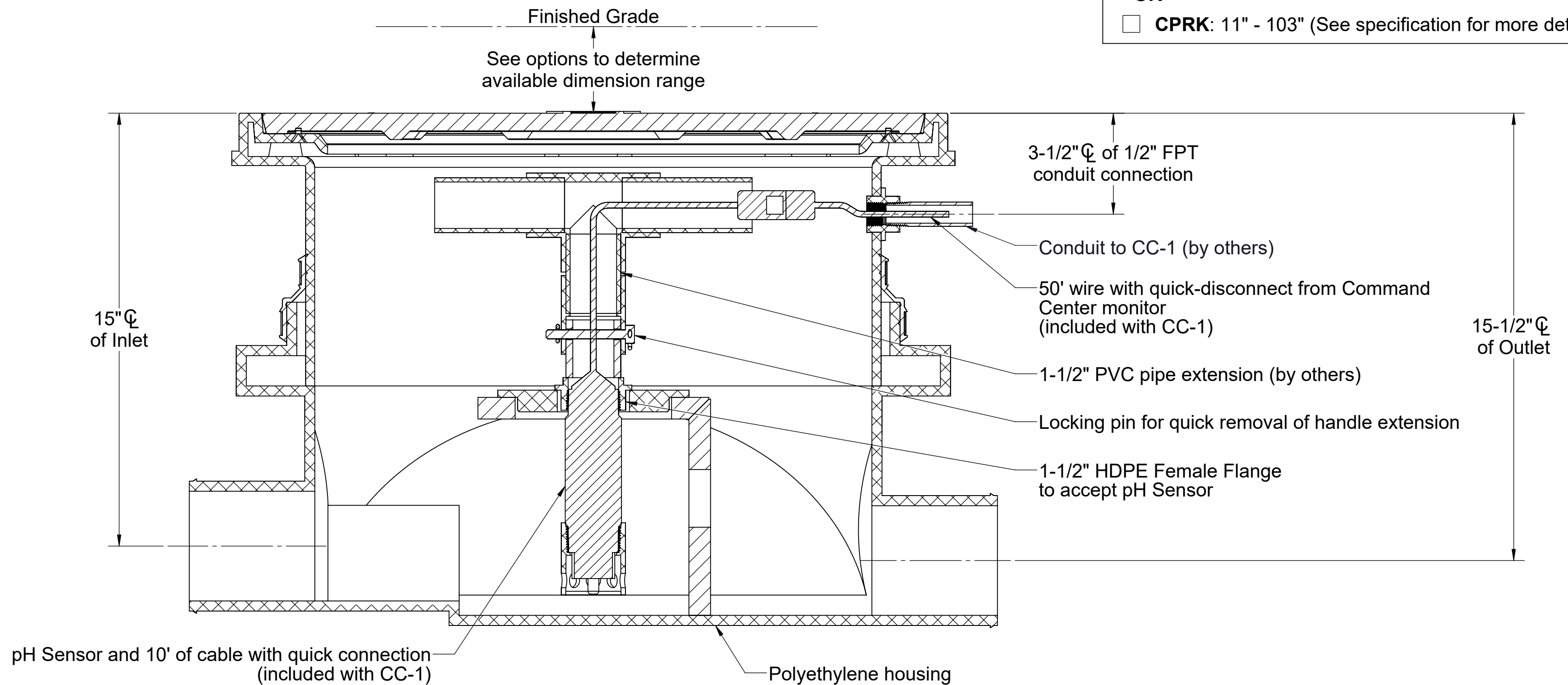

PO IS NON-CANCELABLE  
ORDER IS NON-RETURNABLE

**MODEL NUMBER:** SPK

**DESCRIPTION:**  
SENSOR PLACEMENT KIT FOR  
COMMAND CENTER™ pH MONITORING SYSTEM

**DWG BY:** ENG    **DATE:** 12/9/2024    **REV:** 1

**SPECIFICATION SHEET**

Striem  
Kansas City, KS  
Tel: 913-222-1500  
orders@striemco.com  
www.striemco.com

Made in the U.S.A

