



The World's First

HIGH EFFICIENCY OIL/WATER SEPARATOR LINEUP



AN OIL SEPARATOR **THAT'S GUARANTEED TO WORK:**

- ✓ Certified to IAPMO IGC 325, the industry's first oil separator **performance** standard.
- ✓ Meets EPA hydrocarbon discharge guidance of 100 ppm or less.¹



**LIFETIME
GUARANTEED**



Listed by IAPMO
to IGC 325

**MADE
IN THE
USA**
* BUILT in *
KANSAS CITY

In November 2022, IAPMO published a new industry standard titled *High Efficiency Oil/Water Separators*. The publication introduced a performance-based standard to the oil separator market and created a new term for the industry: **High Efficiency Oil/Water Separator**.

High Efficiency Oil/Water Separator

A device installed in a drainage system that collects hydrocarbons from wastewater with a minimum 90% capture rate.

What is the full name of the new standard?

IAPMO IGC 325 High Efficiency Oil/Water Separators (referred to herein as 'IGC 325').

Why is this new standard important?

Prior to the publication of IGC 325, **there was no standard** to determine whether an oil separator met minimum effluent quality guidelines. Now, manufacturers can subject their oil separators to a rigorous test to determine the efficiency of their product. If the product passes, it may receive a third-party listing and UPC certification from IAPMO.

Do other performance standards exist for oil separators?

No. IGC 325 is the first and only performance standard for oil separators that tests effluent quality. It provides the industry a long-awaited measuring stick to determine how well an oil separator operates.

Does IGC 325 include health and safety design standards?

Yes. In order for a product to pass IGC 325, it must meet material and structural requirements.

What is IGC 325's performance requirement?

The tested oil separator shall separate oil from water at a **minimum of 90% efficiency** at the manufacturer's selected influent flow rate. The influent oil concentration shall be 1,000 mg/L (ppm).

TEST APPARATUS:

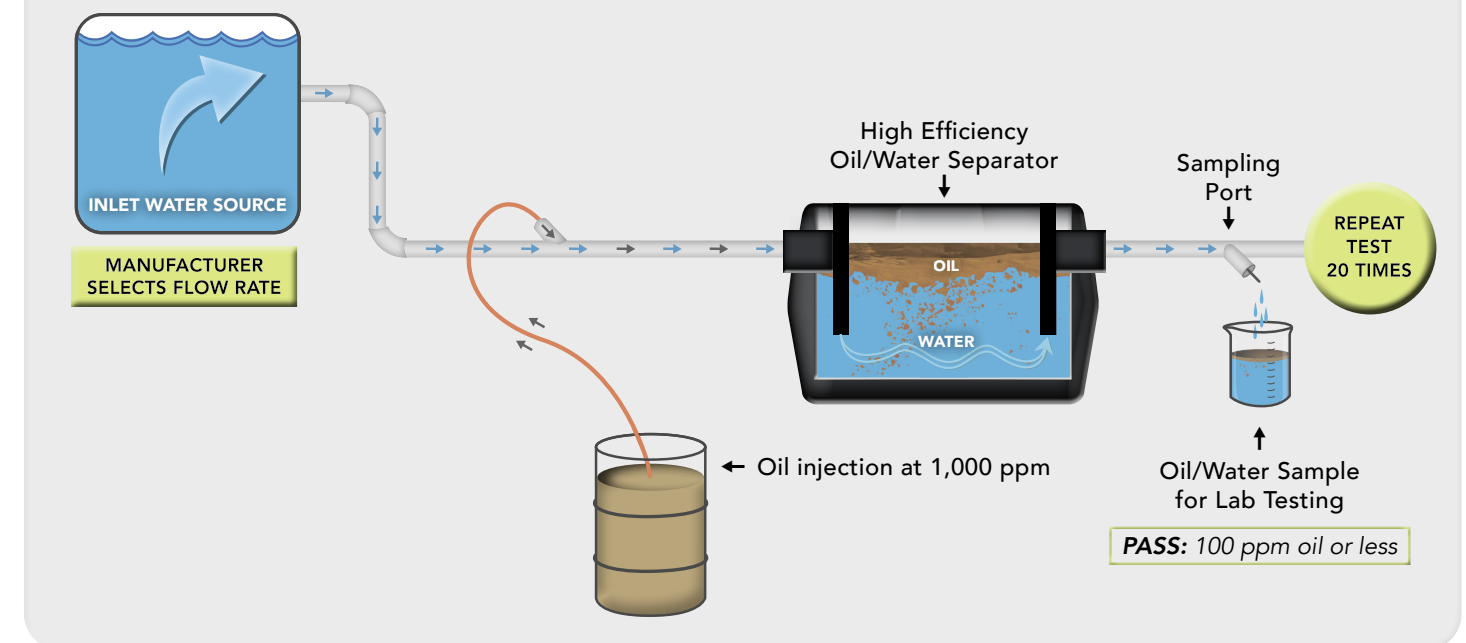

HOW TESTING WORKS:

Step 1

Manufacturer selects flow rate and max oil holding capacity for the tested oil separator. The minimum oil holding capacity shall be 25% of the oil separator's total liquid volume.

Step 2

Begin the 20-batch test process. Each batch has a duration of 5 minutes. Samples are taken during the final minute of each test batch.

Step 3

Oil/water effluent samples are analyzed to EPA Method 1664a by an approved laboratory to determine if the samples pass or fail the efficiency criteria.

OS-25 | EFFICIENCY: **99%**

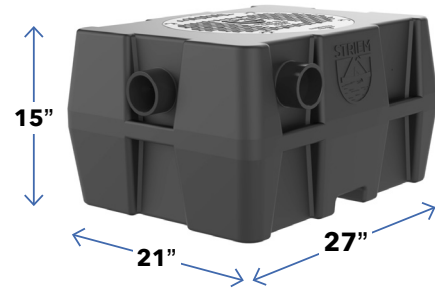

Certified Flow Rate:	25 GPM
Standard Inlet/Outlet Connections:	3"
Vent Connections:	3"
Standard Cover:	Pedestrian rated
Liquid Capacity:	21 gal. (2.8 cu. ft.)
Oil Capacity:	5.25 gal.
Solids Capacity:	6 gal.

OS-50 | EFFICIENCY: **98%**

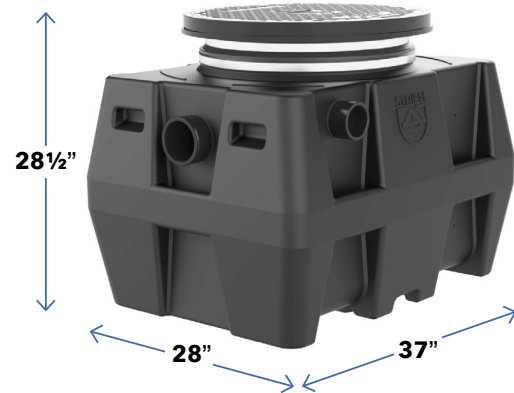

Certified Flow Rate:	50 GPM
Standard Inlet/Outlet Connections:	4"
Vent Connections:	3"
Standard Cover:	Pedestrian rated
Liquid Capacity:	57 gal. (7.6 cu. ft.)
Oil Capacity:	14.25 gal.
Solids Capacity:	7 gal.

Test report and lab sample reports are available on the product webpage or by emailing help@striemco.com.

OPTIONS:

- Field-adjustable risers
- High water hold down kits
- Slick Stick™ oil level monitoring system
- H20 rated cast iron covers

SPEC FORMATS:



*AVAILABLE ONLINE FOR ALL PRODUCTS

OS-75 | EFFICIENCY: **99%**

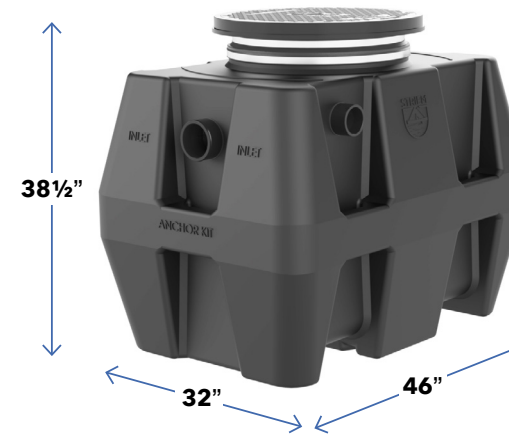

Certified Flow Rate:	75 GPM
Standard Inlet/Outlet Connections:	4"
Vent Connections:	3"
Optional Connection:	6"
Standard Cover:	Traffic rated
Liquid Capacity:	110 gal. (14.7 cu. ft.)
Oil Capacity:	27.5 gal.
Solids Capacity:	11 gal.

OS-100 | EFFICIENCY: **99%**

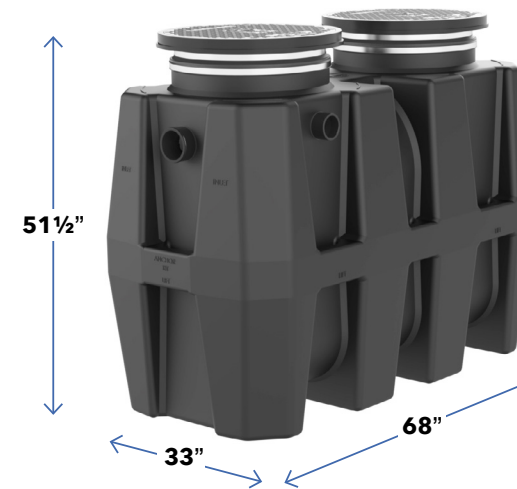

Certified Flow Rate:	100 GPM
Standard Inlet/Outlet Connections:	4"
Vent Connections:	3"
Optional Connection:	6"
Standard Cover:	Traffic rated
Liquid Capacity:	250 gal. (33.4 cu. ft.)
Oil Capacity:	62.5 gal.
Solids Capacity:	95 gal.

OS-350 | EFFICIENCY: **99%**



Certified Flow Rate:	100 GPM
Standard Inlet/Outlet Connections:	4"
Vent Connections:	3"
Optional Connection:	6"
Standard Cover:	Cast Iron (H-20)
Liquid Capacity:	350 gal. (46.8 cu. ft.)
Oil Capacity:	87.5 gal.
Solids Capacity:	114 gal.