

SPECIFICATIONS

1. 4" Plain End inlet/outlet, 3" Plain End vents, C24-HP covers standard.
2. Certified max flow rate: 100 GPM.
3. Liquid capacity: 350 Gallons (46.8 cu. ft.).
4. Oil capacity: 87.5 Gallons.
5. Solids capacity: 114 Gallons.
6. Unit weight w/ standard covers: 410 lbs.; w/ C24-H covers: 290 lbs.
7. Maximum operating temperature 140°F continuous.
8. Slick Stick Oil Level Monitoring System (see page 2).

NOTES

1. Engineered inlet diffuser efficiently separates oil from water.
2. Capped auxiliary vent provided to allow flexibility with vent piping and design. Provided cap can be moved to unused vent location, or discarded if two chamber vents are required per local code.
3. For gravity drainage applications only.
4. Do not use for pressure applications.
5. Cover placement allows full access to tank for proper maintenance.
6. Maximum burial depth: 87" from standard cover height.

ENGINEER SPECIFICATION GUIDE

Striem high efficiency oil/water separator model OS-350-SS shall be lifetime guaranteed and made in the USA. Separator shall be certified to IAPMO IGC 325 and carry a UPC listing. Separator shall be constructed of polyethylene. Separator shall be manufactured for above- or below-grade installation. Field-adjustable riser system is available as an option to bring manhole covers to grade. Separator flow rate shall be 100 GPM. Separator liquid holding capacity shall be 350 gallons and oil capacity shall be 87.5 gallons. Solids capacity shall be 114 gallons. Covers shall be H20 rated pickable cast iron.

IAPMO IGC 325 CERTIFICATION

The OS-350-SS has been third party certified by IAPMO to the IGC 325 standard. The OS-350-SS achieved an average 99% efficiency rating at 100 GPM up to the maximum oil capacity of 87.5 gallons. The structural design has been approved and stamped by a structural engineer for direct burial in accordance with Striem's installation instructions.

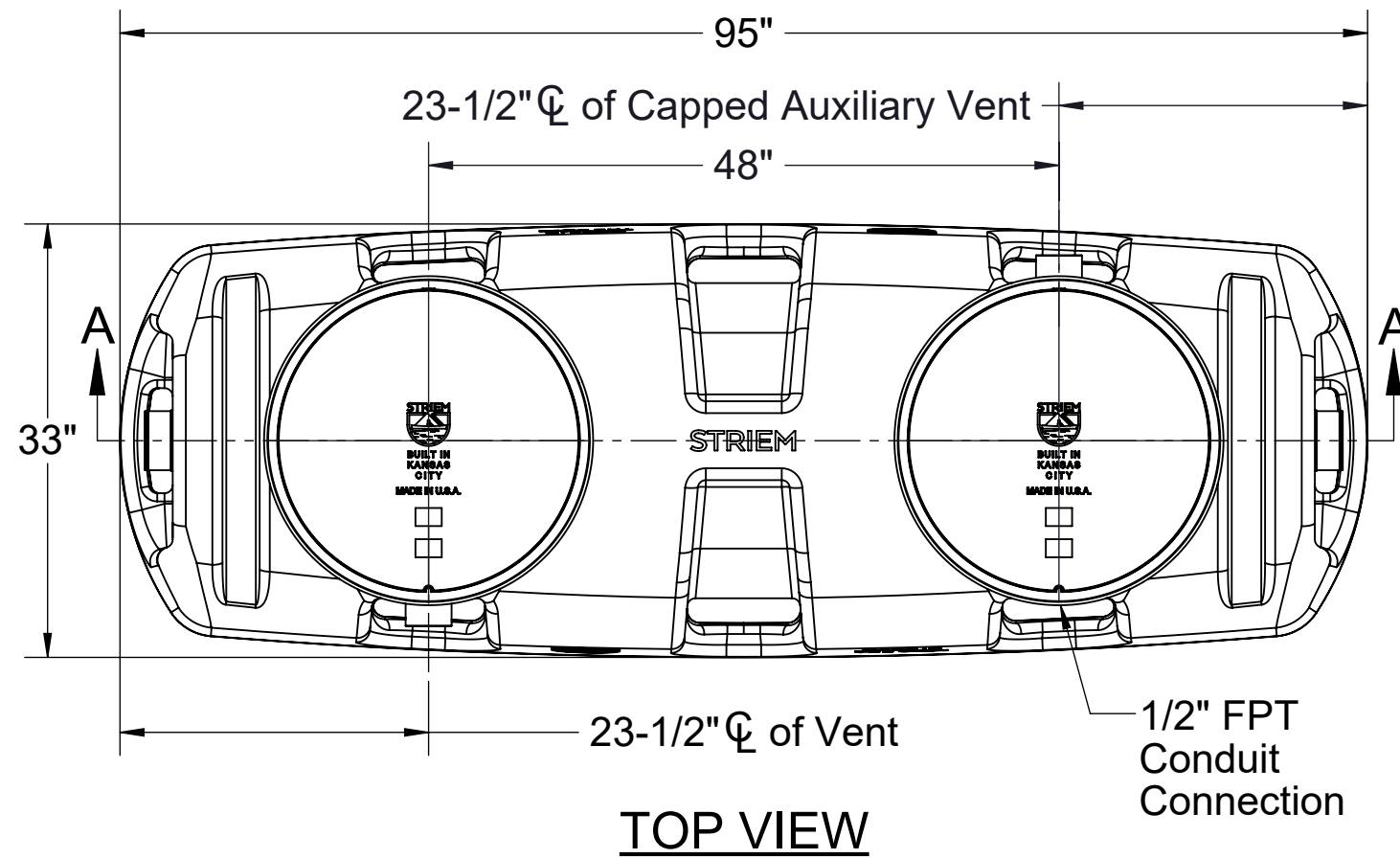

OPTIONS	
Connection Options (Plain End Only)	
Inlet / Outlet	
<input type="checkbox"/> 4"	
<input type="checkbox"/> 6"	
Riser Options	
From Factory: Up to 2"	
<input type="checkbox"/> Up to 21": SR24 (2)	
<input type="checkbox"/> Up to 36": LR24 (2)	
<input type="checkbox"/> Up to 40": SR24 (4)	
<input type="checkbox"/> Up to 55": SR24 (2) + LR24 (2)	
<input type="checkbox"/> Up to 69": LR24 (4)	
<input type="checkbox"/> Up to 87": SR24 (2) + LR24 (4)	
-OR-	
<input type="checkbox"/> CPRK (2): 11" - 87" (See specification for more detail.)	
Additional Options	
High Water Table Hold Down Kits (Choose One)	
<input type="checkbox"/> HDK-11 : With Steel Plates Included	
<input type="checkbox"/> HDK-12 : For Concrete Deadmen (By Others)	
<input type="checkbox"/> C24-H (2): Highway Rated Bolted Composite Cover*	
*For above-grade installations.	

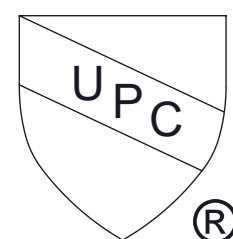
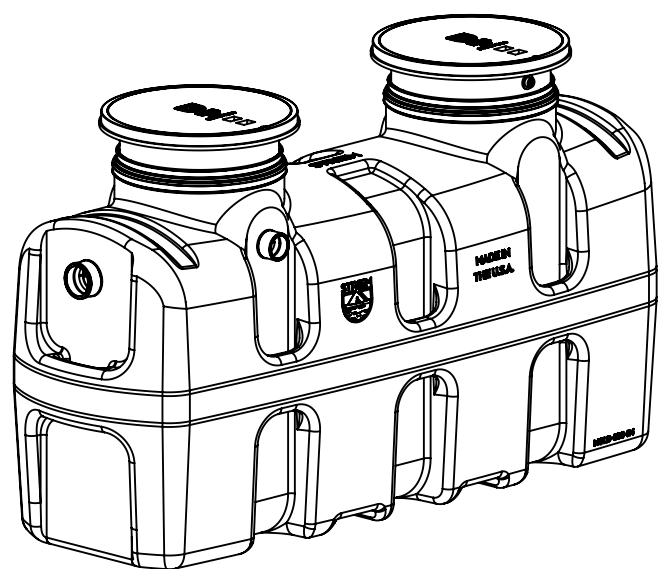
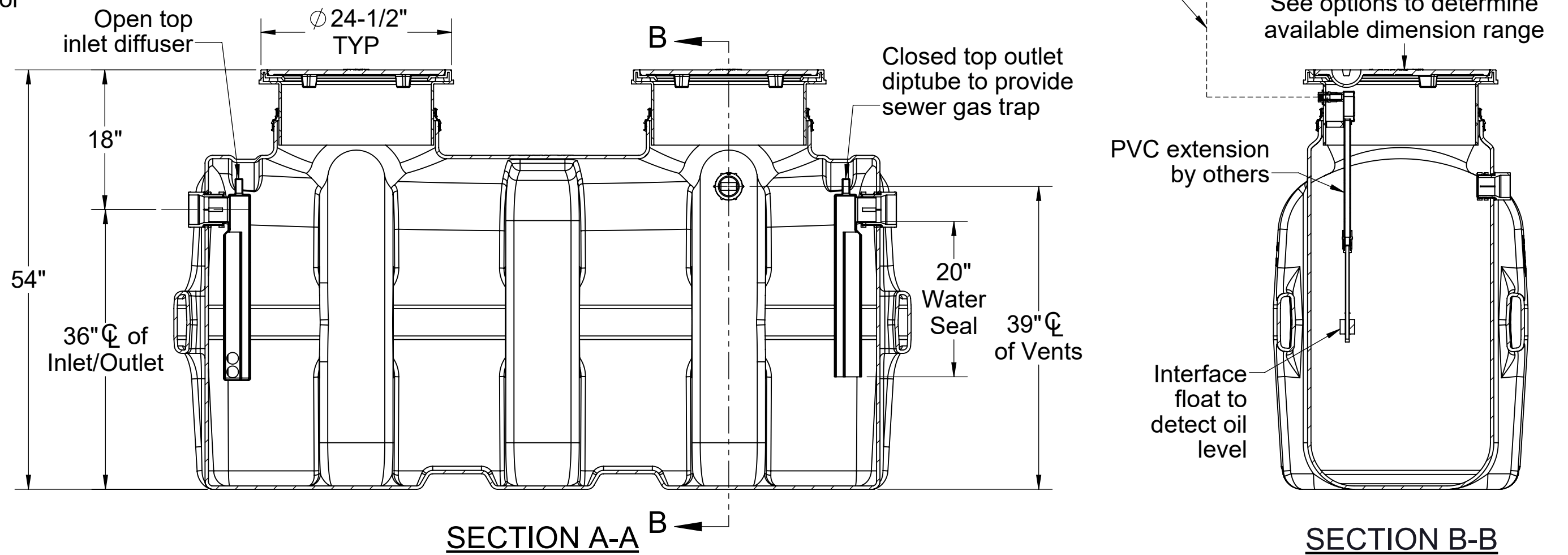

PROPRIETARY AND CONFIDENTIAL
 THE INFORMATION CONTAINED IN THIS DRAWING IS THE SOLE PROPERTY OF STRIEM, LLC.
 ANY REPRODUCTION IN PART OR AS A WHOLE WITHOUT THE WRITTEN PERMISSION OF STRIEM, LLC. IS PROHIBITED.

MODEL NUMBER:	OS-350-SS
DESCRIPTION:	100 GPM POLYETHYLENE HIGH EFFICIENCY OIL/WATER SEPARATOR WITH SLICK STICK™ OIL LEVEL MONITORING SYSTEM
DWG BY:	ENG
DATE:	1/15/2025
REV:	0

SPECIFICATION SHEET

Striem
 Kansas City, KS
 Tel: 913-222-1500
 orders@striemco.com
 www.striemco.com
 Made in the U.S.A



SPECIFICATIONS

1. UL Listed
2. Provides warning of high oil level conditions with interface float.
3. Single phase, 120 volt, 60 hertz power required.
4. NEMA 4X fiberglass, corrosion resistant, weatherproof enclosure suitable for outdoor use and damp environments.
5. Audible Alarm Buzzer, 95dB pulsing horn with no timeout.
6. High Oil Light, indicates oil has accumulated below the oil interface float or the tank liquid level is below the High Oil Interface Float.
7. Power On light inside enclosure. Visible from the outside. Green light indicates the power is on.
8. Horn off button that silences the audible alarm when pressed.
9. Test button that when pressed will test the system electronics.
10. Locking clasp on door.
11. Alarm bell stays on until reset. Light stays on until reset, even if level goes down.
12. Unit comes supplied with extra dry contact for connection to a building alarm system.

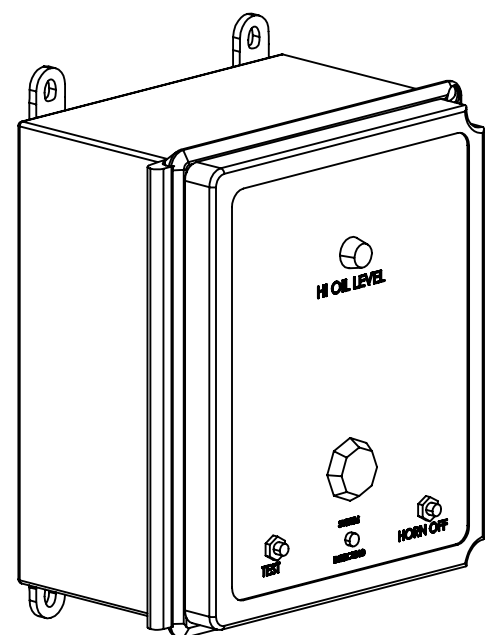
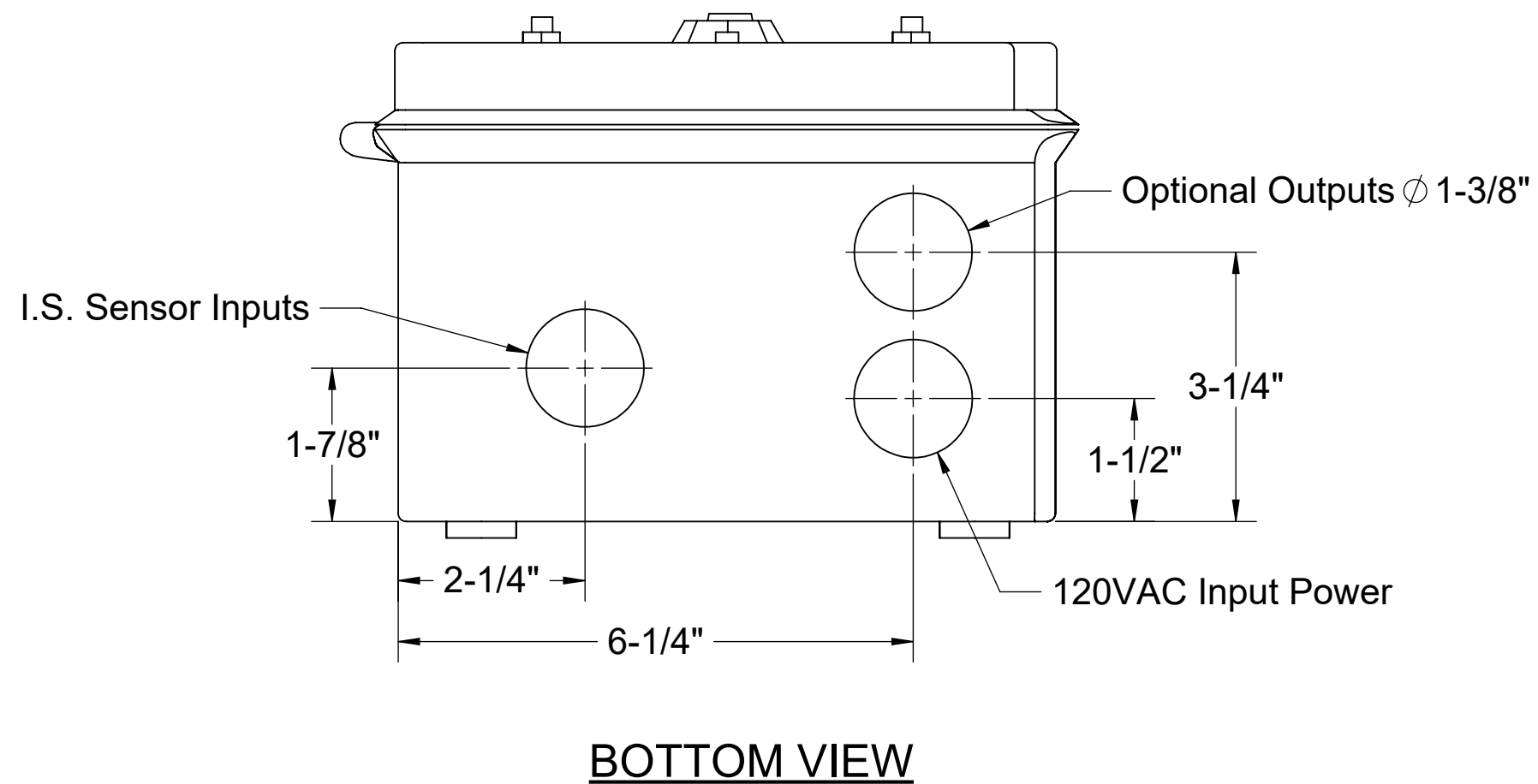
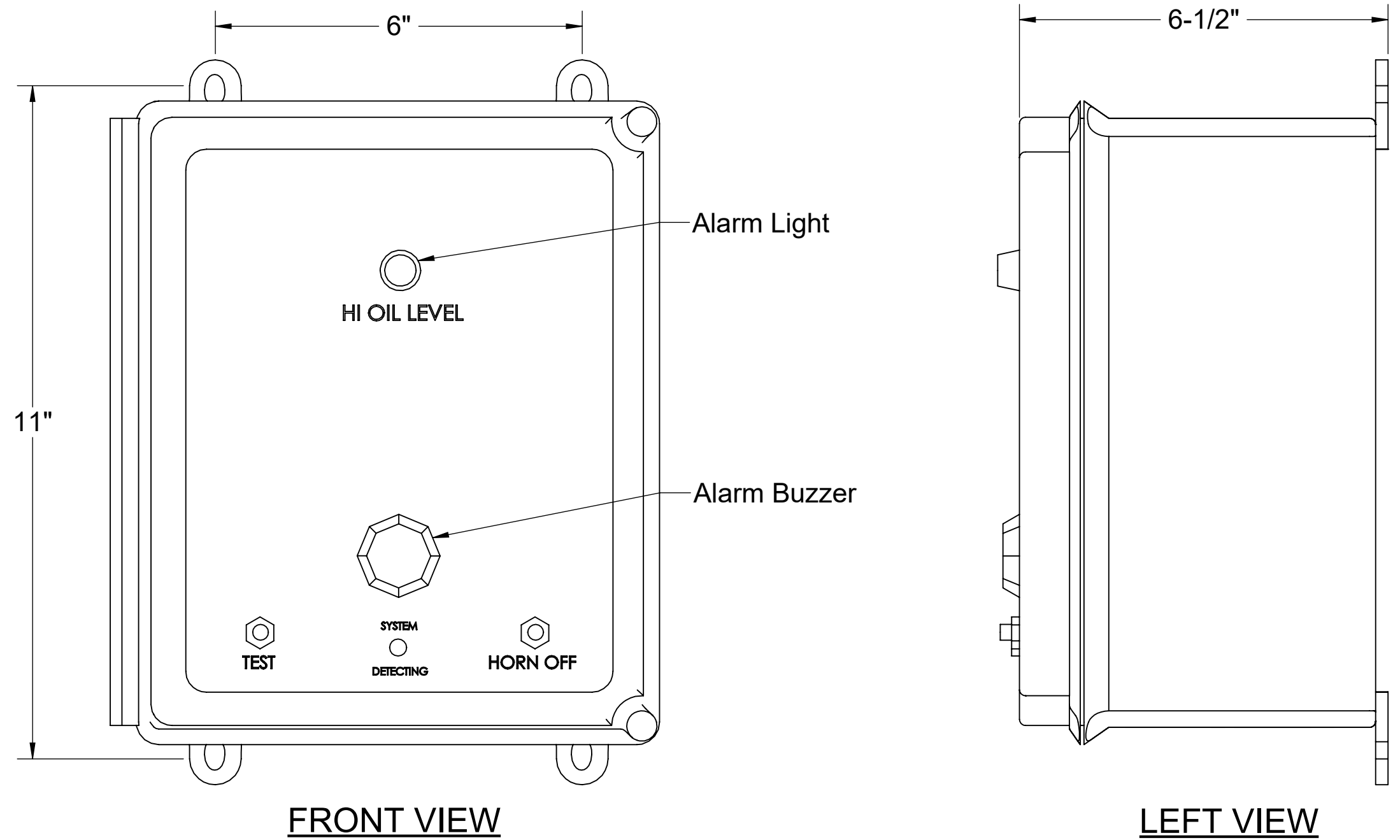
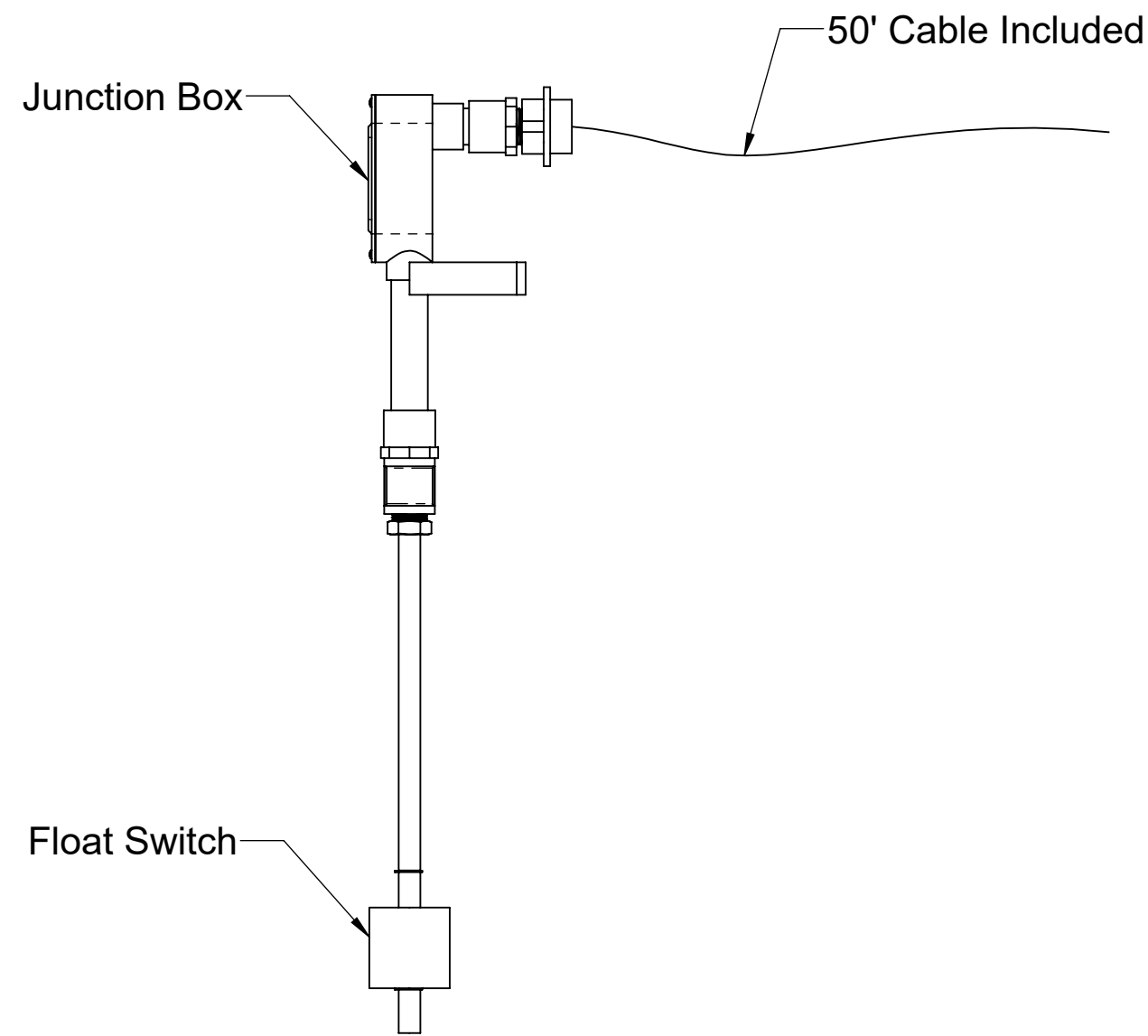

PROPRIETARY AND CONFIDENTIAL
 THE INFORMATION CONTAINED IN THIS DRAWING IS THE SOLE PROPERTY OF STRIEM, LLC.
 ANY REPRODUCTION IN PART OR AS A WHOLE WITHOUT THE WRITTEN PERMISSION OF STRIEM, LLC. IS PROHIBITED.

MODEL NUMBER: SS		SPECIFICATION SHEET	
DESCRIPTION: SLICK STICK™ OIL LEVEL MONITORING SYSTEM			
DWG BY: ENG	DATE: 5/19/2023	REV: 0	Striem Kansas City, KS Tel: 913-222-1500 orders@striemco.com www.striemco.com Made in the U.S.A