

**SPECIFICATIONS**

1. 4" Plain End inlet/outlet, 3" Plain End vents, C24-HP covers standard.
2. Certified max flow rate: 100 GPM.
3. Liquid capacity: 350 Gallons (46.8 cu. ft.).
4. Oil capacity: 87.5 Gallons.
5. Solids capacity: 114 Gallons.
6. Unit weight w/ standard covers: 410 lbs.; w/ C24-H covers: 290 lbs.
7. Maximum operating temperature 140°F continuous.

**NOTES**

1. Engineered inlet diffuser efficiently separates oil from water.
2. Capped auxiliary vent provided to allow flexibility with vent piping and design. Provided cap can be moved to unused vent location, or discarded if two chamber vents are required per local code.
3. For gravity drainage applications only.
4. Do not use for pressure applications.
5. Cover placement allows full access to tank for proper maintenance.
6. Maximum burial depth: 90" from standard cover height.

**ENGINEER SPECIFICATION GUIDE**

Striem high efficiency oil/water separator model OS-350 shall be lifetime guaranteed and made in the USA. Separator shall be certified to IAPMO IGC 325 and carry a UPC listing. Separator shall be constructed of polyethylene. Separator shall be manufactured for above- or below-grade installation. Field-adjustable riser system is available as an option to bring manhole covers to grade. Separator flow rate shall be 100 GPM. Separator liquid holding capacity shall be 350 gallons and oil capacity shall be 87.5 gallons. Solids capacity shall be 114 gallons. Covers shall be H20 rated pickable cast iron.

**IAPMO IGC 325 CERTIFICATION**

The OS-350 has been third party certified by IAPMO to the IGC 325 standard. The OS-350 achieved an average 99% efficiency rating at 100 GPM up to the maximum oil capacity of 87.5 gallons. The structural design has been approved and stamped by a structural engineer for direct burial in accordance with Striem's installation instructions.

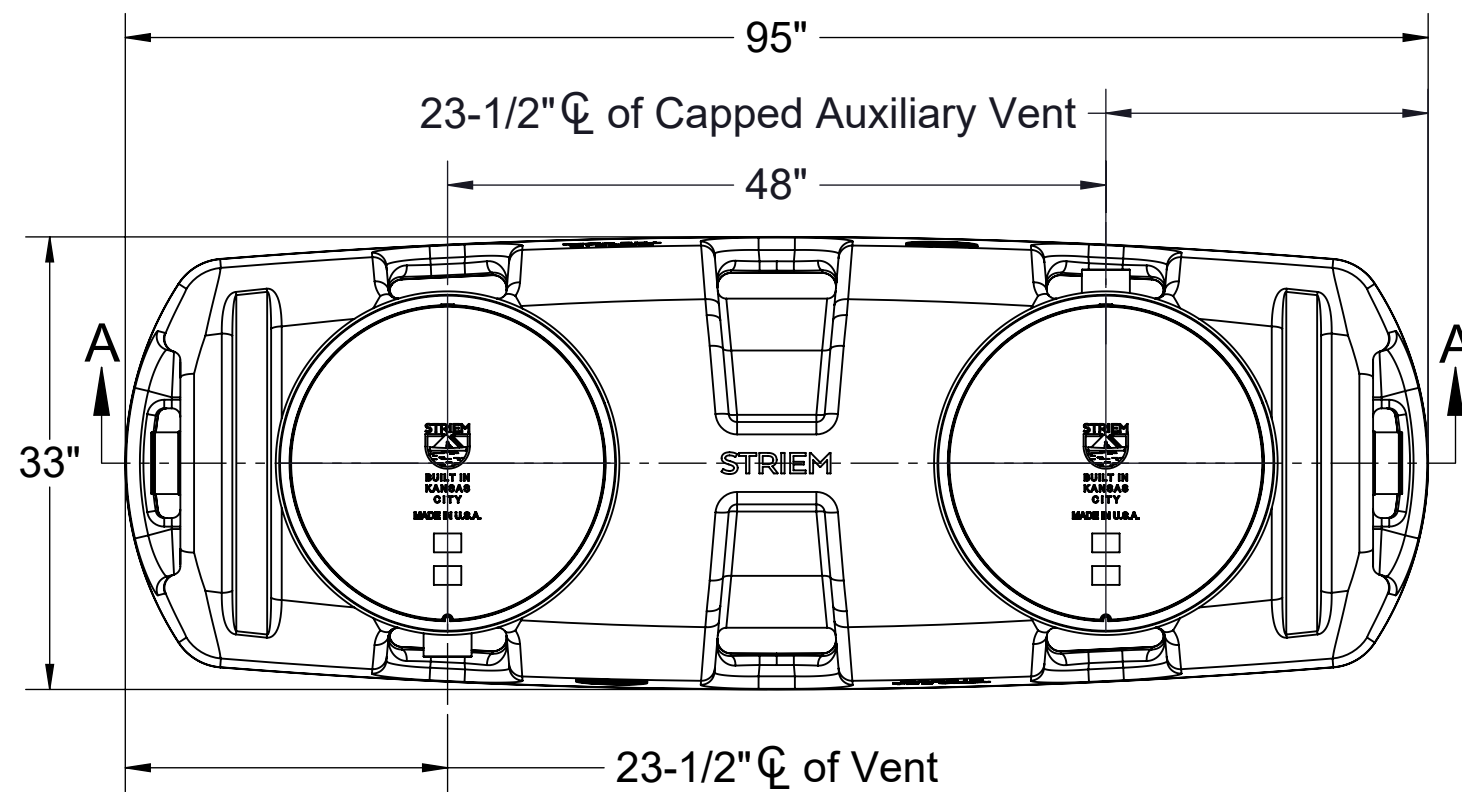

**TOP VIEW**

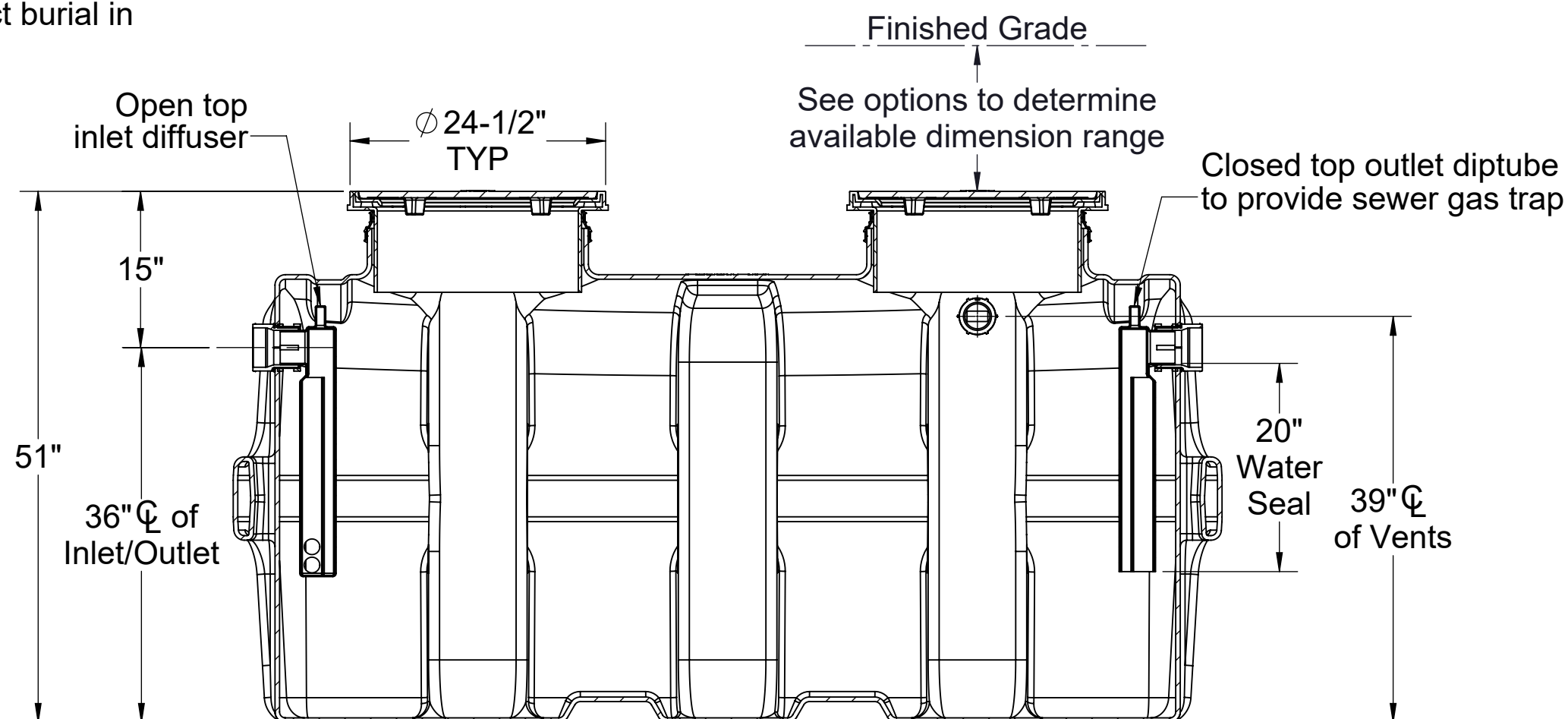

**SECTION A-A**

OPTIONS	
<b>Connection Options (Plain End Only)</b>	
<b>Inlet / Outlet</b>	
<input type="checkbox"/> 4"	
<input type="checkbox"/> 6"	
<b>Riser Options</b>	
<b>From Factory: Up to 5"</b>	
<input type="checkbox"/> Up to 24": <b>SR24</b> (2)	
<input type="checkbox"/> Up to 39": <b>LR24</b> (2)	
<input type="checkbox"/> Up to 43": <b>SR24</b> (4)	
<input type="checkbox"/> Up to 58": <b>SR24</b> (2) + <b>LR24</b> (2)	
<input type="checkbox"/> Up to 72": <b>LR24</b> (4)	
<input type="checkbox"/> Up to 90": <b>SR24</b> (2) + <b>LR24</b> (4)	
<b>-OR-</b>	
<input type="checkbox"/> <b>CPRK</b> (2): 11" - 90" (See specification for more detail.)	
<b>Additional Options</b>	
<b>High Water Table Hold Down Kits (Choose One)</b>	
<input type="checkbox"/> <b>HDK-11</b> : With Steel Plates Included	
<input type="checkbox"/> <b>HDK-12</b> : For Concrete Deadmen (By Others)	
<input type="checkbox"/> <b>C24-H</b> (2): Highway Rated Bolted Composite Cover*	
<input type="checkbox"/> <b>SS</b> : Slick Stick™ Oil Level Monitoring System**	
*For above-grade installations.	
**Monitoring system will raise covers by 3".	

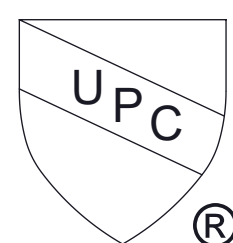
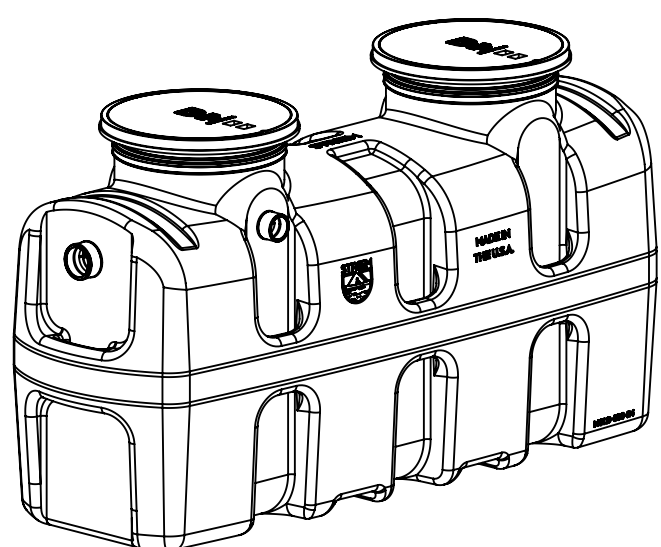

**PROPRIETARY AND CONFIDENTIAL**  
THE INFORMATION CONTAINED IN THIS DRAWING IS THE SOLE PROPERTY OF STRIEM, LLC. ANY REPRODUCTION IN PART OR AS A WHOLE WITHOUT THE WRITTEN PERMISSION OF STRIEM, LLC. IS PROHIBITED.

<b>MODEL NUMBER:</b>	OS-350
<b>DESCRIPTION:</b>	100 GPM POLYETHYLENE HIGH EFFICIENCY OIL/WATER SEPARATOR
<b>DWG BY:</b> ENG	<b>DATE:</b> 1/15/2025
<b>REV:</b> 0	

**SPECIFICATION SHEET**

Striem  
Kansas City, KS  
Tel: 913-222-1500  
orders@striemco.com  
www.striemco.com

Made in the U.S.A

