

**SPECIFICATIONS**

1. 6" Plain End inlet/outlet shown, 3" Plain End vents standard.
2. Max flow rate: 314 GPM.
3. Liquid capacity: 562 Gallons (75 cu. ft.).
4. Oil capacity: 285 Gallons.
5. Solids capacity: 162 Gallons.
6. Unit weight: 1025 lbs.
7. Maximum operating temperature 140 °F continuous.
8. Slick Stick Oil Level Monitoring System (see page 2).

**NOTES**

1. For gravity drainage applications only.
2. Do not use for pressure applications.
3. Capped auxiliary vent provided to allow flexibility with vent piping and design. Provided cap can be moved to unused vent location, or discarded if two chamber vents are required per local code.
4. Cover placement allows full access to tank for proper maintenance.
5. Lifting lug set for easy install.
6. Maximum burial depth: 103" from standard cover height.

**ENGINEER SPECIFICATION GUIDE**

Striem oil separator model OT-500-SS shall be lifetime guaranteed and made in the USA. Separator shall be constructed of polyethylene with 7/8" nominal wall thickness. Separator shall be manufactured for below-grade installation. Field-adjustable riser system is available as an option to bring manhole covers to grade. Separator flow rate shall be 314 GPM. Separator liquid holding capacity shall be 562 gallons and oil capacity shall be 285 gallons. Solids capacity shall be 162 gallons. Covers shall be H20 rated pickable cast iron. Separator shall be certified to IAPMO IGC 183-2016 and carry a UPC listing.

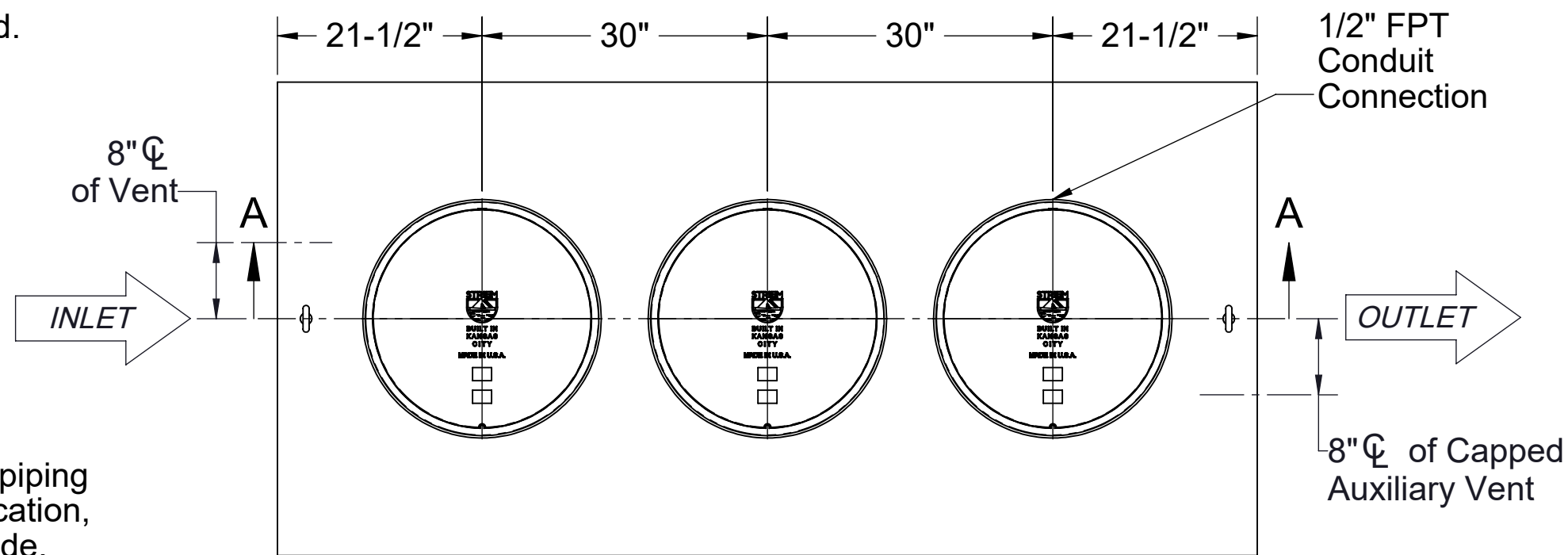

**TOP VIEW**

**OPTIONS**

**Connection Options (Plain End Only)**

**Inlet / Outlet**

- 4"
- 6"
- 8"

**SELECTION REQUIRED**

**Riser Options**

**From Factory: Up to 2"**

- Up to 21": **SR24** (3)
- Up to 36": **LR24** (3)
- Up to 40": **SR24** (6)
- Up to 55": **SR24** (3) + **LR24** (3)
- Up to 69": **LR24** (6)
- Up to 87": **SR24** (3) + **LR24** (6)
- Up to 103": **LR24** (9)

**- OR -**

- CPRK** (3): 11" - 103"

(See specification for more detail.)

**Additional Options**

- HDK-3**: High Water Table Hold Down Kit

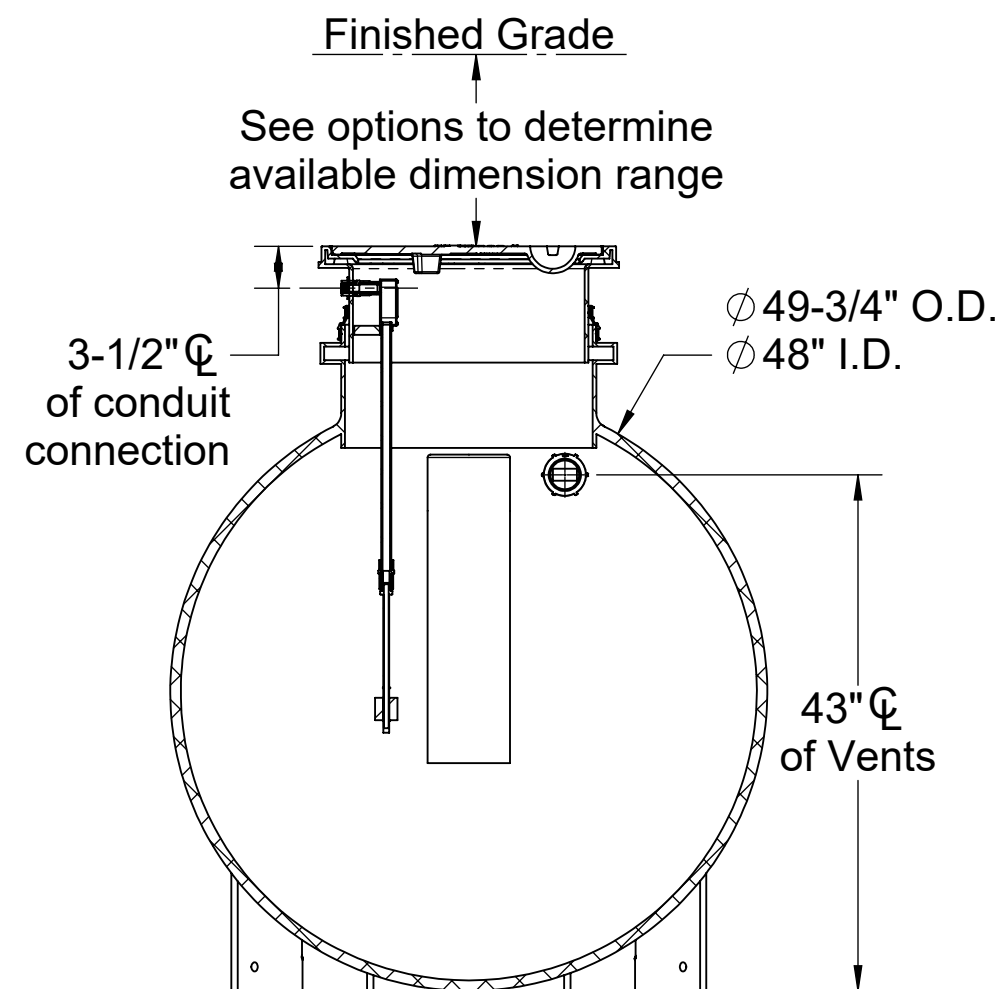

**SECTION B-B**

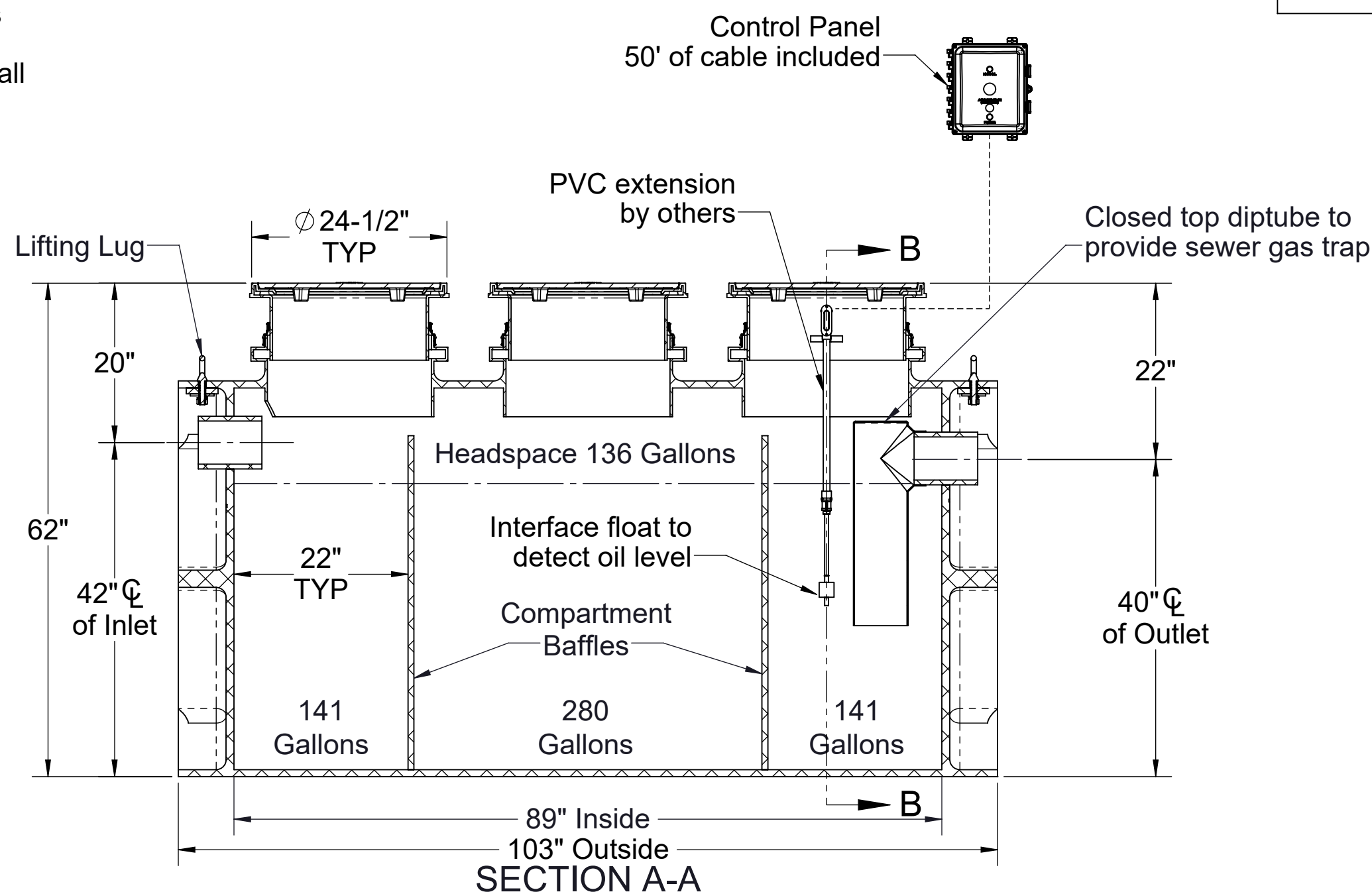

**SECTION A-A**

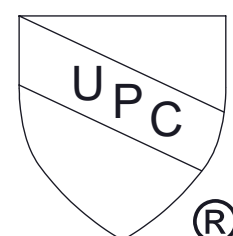
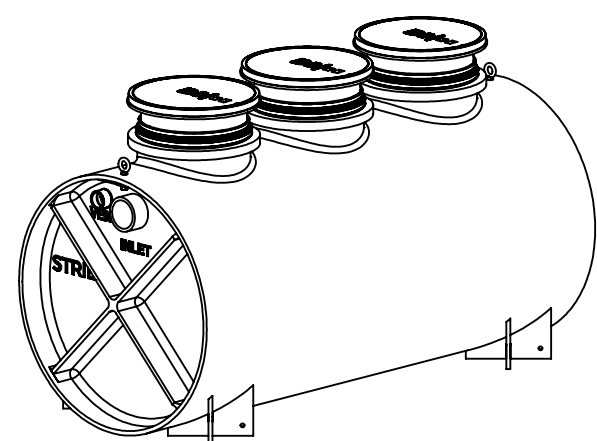

**PO IS NON-CANCELABLE ORDER IS NON-RETURNABLE**

**PROPRIETARY AND CONFIDENTIAL**  
THE INFORMATION CONTAINED IN THIS DRAWING IS THE SOLE PROPERTY OF STRIEM, LLC. ANY REPRODUCTION IN PART OR AS A WHOLE WITHOUT THE WRITTEN PERMISSION OF STRIEM, LLC. IS PROHIBITED.

**MODEL NUMBER:** OT-500-SS

**DESCRIPTION:**  
OIL TANKER™  
POLYETHYLENE OIL SEPARATOR WITH  
SLICK STICK™ OIL LEVEL MONITORING SYSTEM  
562 GALLON CAPACITY

**DWG BY:** ENG    **DATE:** 1/23/2025    **REV:** 1

**SPECIFICATION SHEET**

Striem  
Kansas City, KS  
Tel: 913-222-1500  
orders@striemco.com  
www.striemco.com

Made in the U.S.A



**SPECIFICATIONS**

1. UL Listed.
2. Provides warning of high oil level conditions with interface float.
3. Single phase, 120 volt, 60 hertz power required.
4. NEMA 4X fiberglass, corrosion resistant, weatherproof enclosure suitable for outdoor use and damp environments.
5. Audible Alarm Buzzer, 95dB pulsing horn with no timeout.
6. High Oil Light, indicates oil has accumulated below the oil interface float or the tank liquid level is below the High Oil Interface Float.
7. Power On light inside enclosure. Visible from the outside. Green light indicates the power is on.
8. Horn off button that silences the audible alarm when pressed.
9. Test button that when pressed will test the system electronics.
10. Locking clasp on door.
11. Alarm bell stays on until reset. Light stays on until reset, even if level goes down.
12. Unit comes supplied with extra dry contact for connection to a building alarm system.

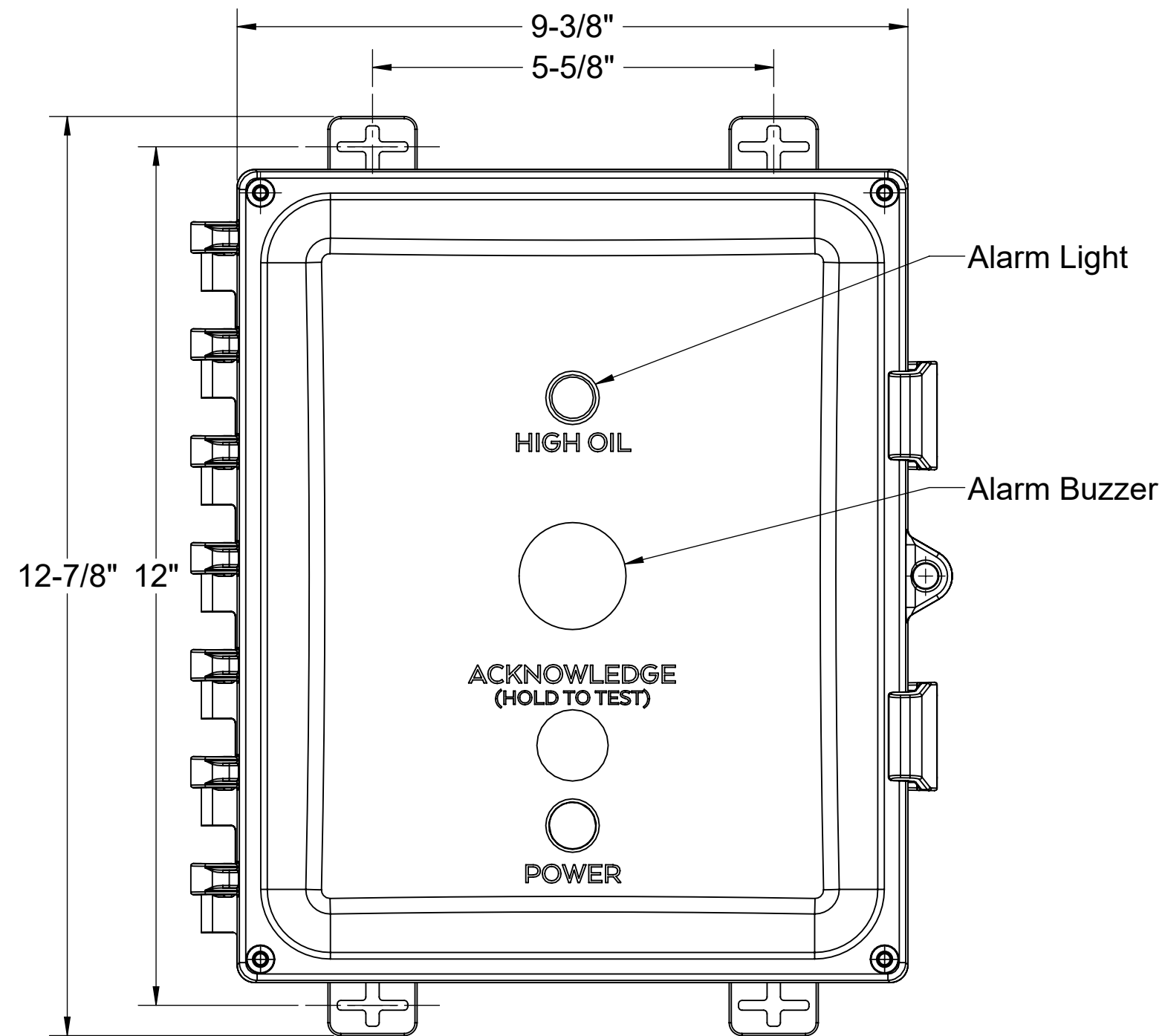
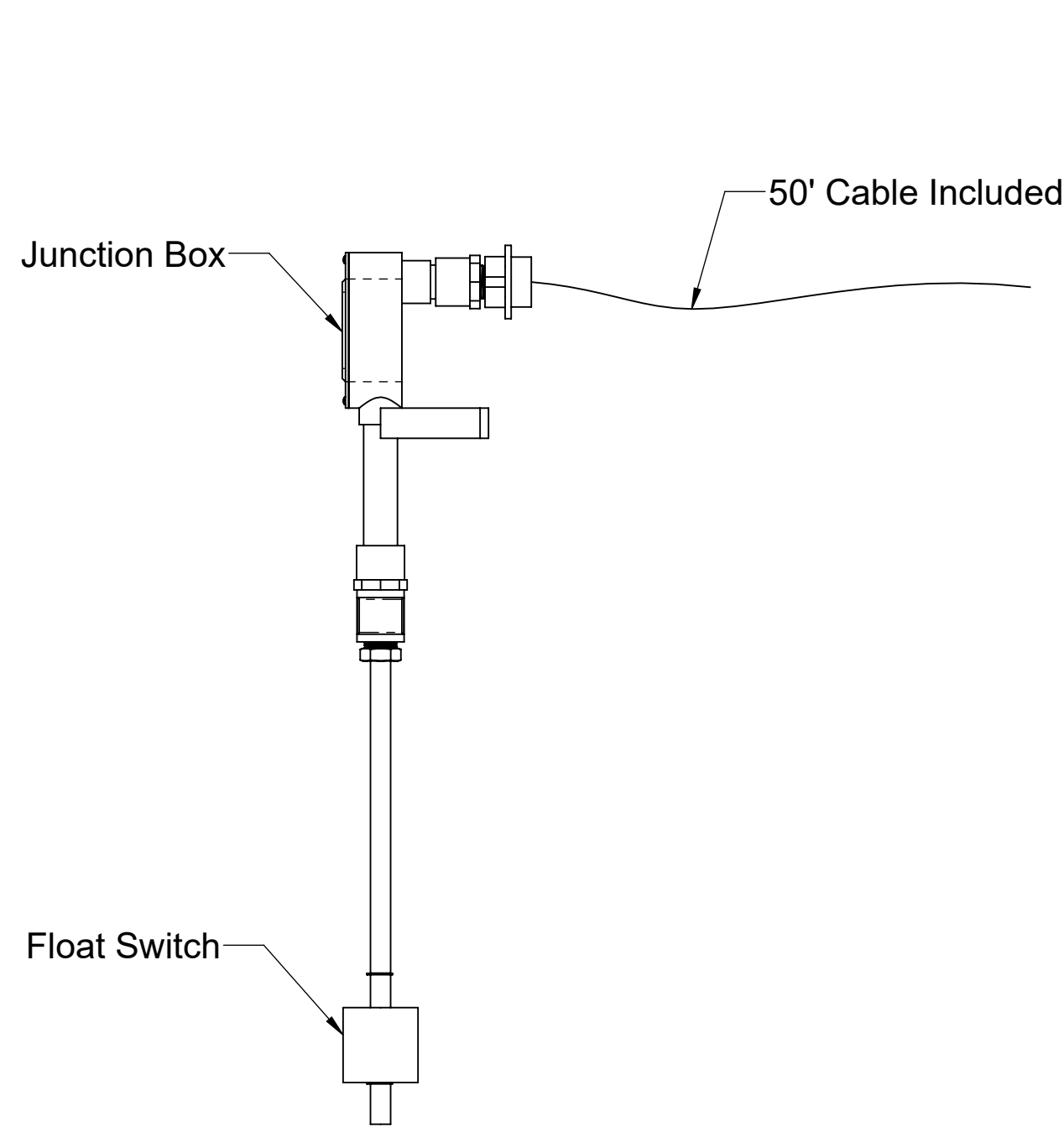

**FRONT VIEW**

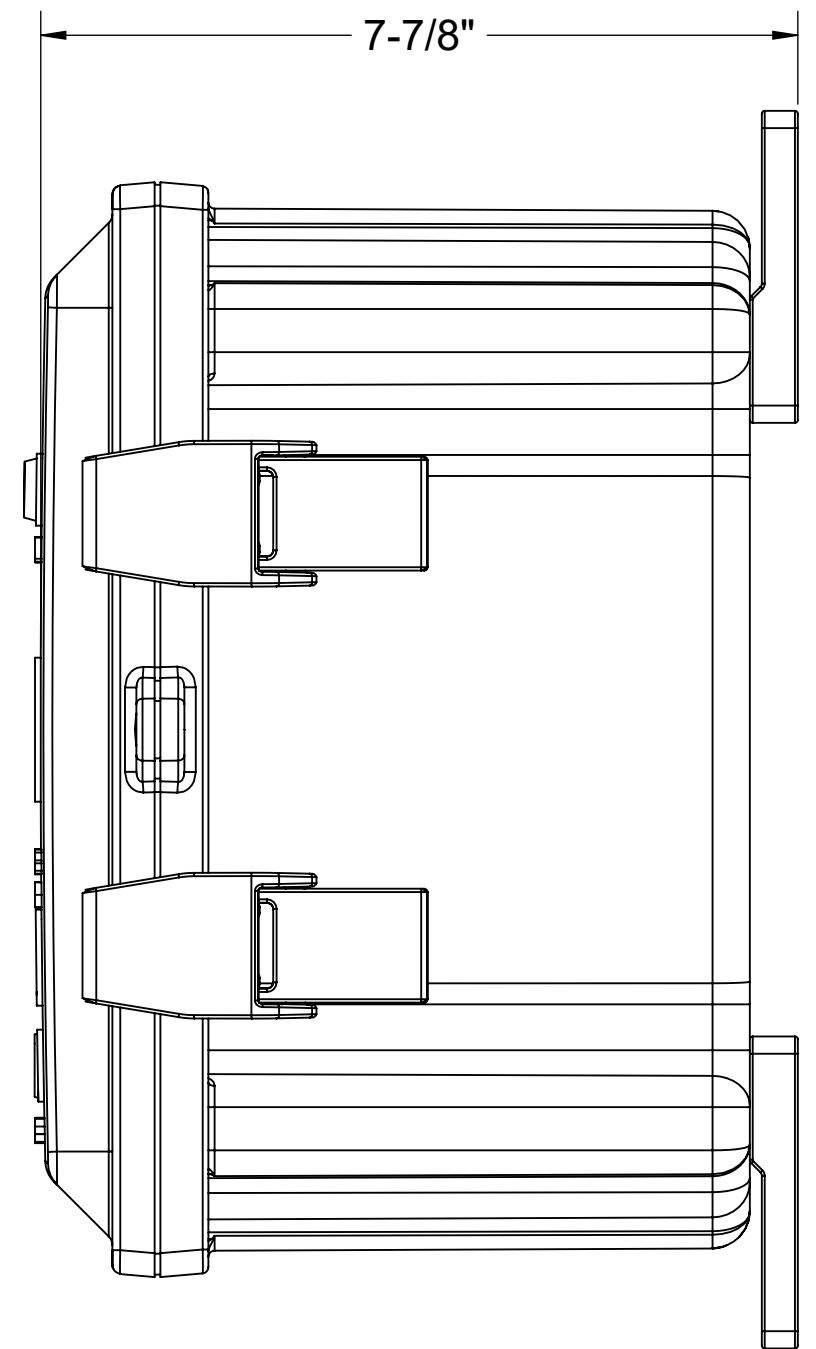

**SIDE VIEW**

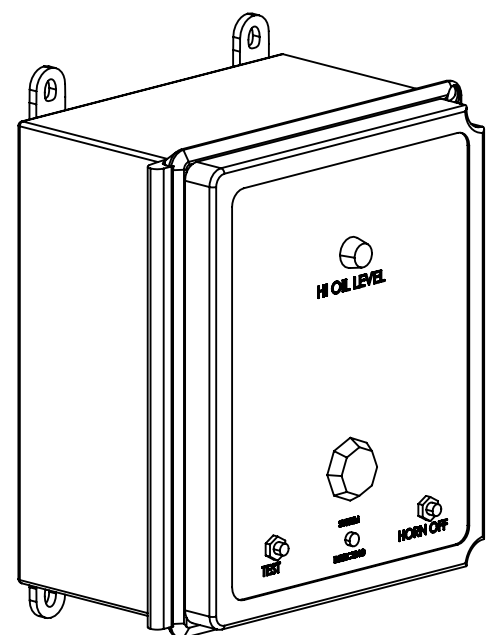

**PROPRIETARY AND CONFIDENTIAL**  
 THE INFORMATION CONTAINED IN THIS DRAWING IS THE SOLE PROPERTY OF STRIEM, LLC.  
 ANY REPRODUCTION IN PART OR AS A WHOLE WITHOUT THE WRITTEN PERMISSION OF STRIEM, LLC. IS PROHIBITED.

<b>MODEL NUMBER:</b> SS		<b>SPECIFICATION SHEET</b>	
<b>DESCRIPTION:</b> SLICK STICK™ OIL LEVEL MONITORING SYSTEM			
<b>DWG BY:</b> ENG	<b>DATE:</b> 11/20/2024	<b>REV:</b> 1	Striem Kansas City, KS Tel: 913-222-1500 orders@striemco.com www.striemco.com Made in the U.S.A