

EXCAVATION

1. Surrounding soil must be undisturbed soil or well compacted engineering fill.
2. Measure the width and length of the tank and excavate a hole that is a minimum of 18" greater than the tank on all sides.
3. Depth of excavation shall be 12" deeper than tank bottom.
4. After the excavation is complete create a well compacted support layer of aggregate mixture so that ground supporting tank is a minimum of 12" above native soil. Aggregate mixture must be 3/4" size clean rock or sand, with no fines. For compaction, use a flat plate compactor to tamper rock or sand evenly for 15 minutes.

UNIT INSTALLATION

1. Lower and center the unit into hole using Striem lifting lug kit (included). Do not use chains or accessways to move the unit.
2. Ensure tops of risers are level with finished grade.
3. Fill unit with water before backfilling to stabilize unit, check for leaks, and prevent float out during backfilling.

BACKFILLING & FINISHED CONCRETE SLAB

1. Before backfilling and pouring of slab secure covers and risers (if necessary) to the unit.
2. Backfill evenly all around tank using crushed aggregate material approximately 3/4" size rock, or sand, with no fines.
3. When backfilling ensure backfill is worked under the unit using a probe to ensure the unit is fully supported.
4. Place 6" aggregate base under slab. Aggregate should be 3/4" size rock, or sand, with no fines.
5. H20 rated slab required.
6. Concrete to be 28 day compressive strength to 4000 PSI with 6±1% air entrainment.
7. NO. 4 rebar (Ø 1/2") grade 60 steel per ASTM A615: connected with tie wire.
8. Rebar to be 2 1/2" from edge of concrete.
9. Rebar spacing 12" grid. 4" spacing around access openings.

DEADMAN ANCHORING

1. Deadmen should be constructed as noted on Excavation and Backfill detail.
2. Deadmen should be 12" wide x 12" tall and equal to the length of the entire unit.
3. Each deadman should have 2 anchor points that each connect to a 3,500 lbs. rated turnbuckle.
4. Lay the deadmen parallel with the unit and ensure that they are outside the shadow of the tank.
5. Nylon straps rated to 3,333 lbs. each should be connected to a turnbuckle on each side. Turnbuckles should be secured to the deadmen anchor points on each side of the tank such that the tank is held down.

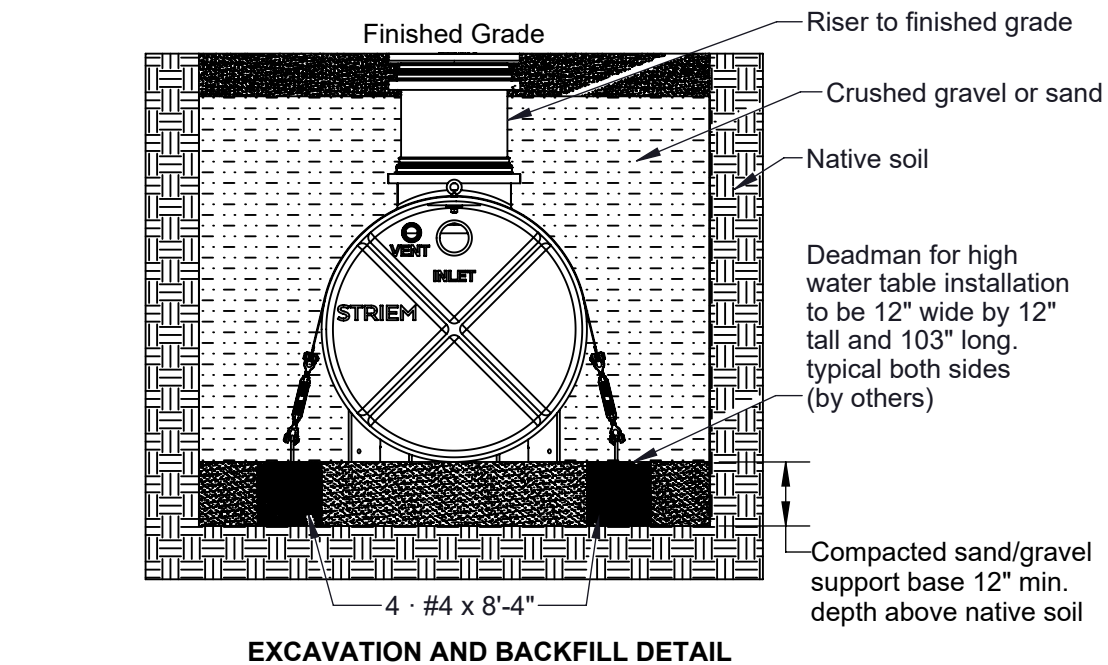
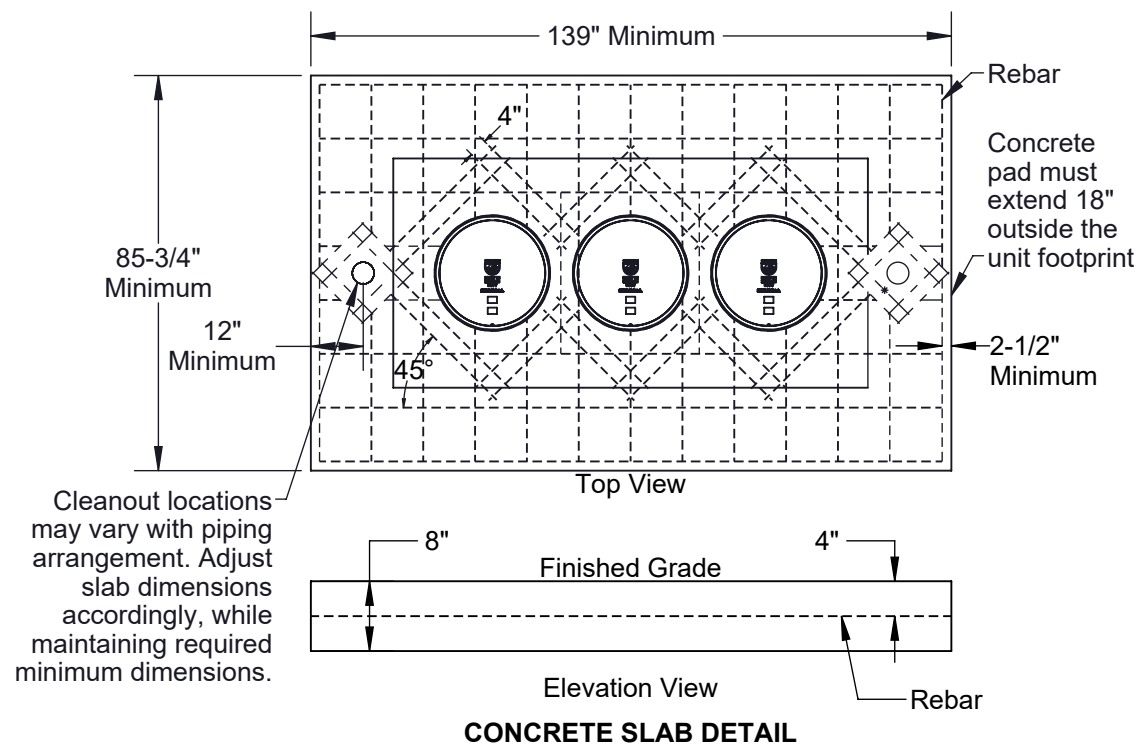

SPECIFICATIONS

1. 6" Plain End inlet/outlet shown, 3" Plain End vents standard.
2. Max flow rate: 314 GPM.
3. Liquid capacity: 562 gallons (75 cu. ft.).
4. Oil capacity: 285 gallons.
5. Solids capacity: 162 gallons.
6. Unit weight: 1025 lbs.
7. Maximum operating temperature 140°F continuous.

NOTES

1. For gravity drainage applications only.
2. Do not use for pressure applications.
3. Capped auxiliary vent provided to allow flexibility with vent piping and design. Provided cap can be moved to unused vent location, or discarded if two chamber vents are required per local code.
4. Cover placement allows full access to tank for proper maintenance.
5. Lifting lug set for easy install.
6. Maximum burial depth: 120" from the crown of the inlet.

ENGINEER SPECIFICATION GUIDE

Striem oil separator model OT-500-JCW shall be lifetime guaranteed and made in the USA. Separator shall be constructed of polyethylene with 7/8" nominal wall thickness. Separator shall be manufactured for below-grade installation. Field-adjustable riser system is available as an option to bring manhole covers to grade. Separator flow rate shall be 314 GPM. Separator liquid holding capacity shall be 562 gallons and oil capacity shall be 285 gallons. Solids capacity shall be 162 gallons. Covers shall be H20 rated pickable cast iron. Separator shall be certified to IAPMO IGC 183-2016 and carry a UPC listing.

OPTIONS

Connection Options	
Inlet / Outlet	SELECTION REQUIRED
<input type="checkbox"/> 4"	
<input type="checkbox"/> 6"	
<input type="checkbox"/> 8"	
Riser Options	
<input type="checkbox"/> 30" - 38": SR24 (3)	
<input type="checkbox"/> Up to 53": LR24 (3)	
<input type="checkbox"/> Up to 57": SR24 (6)	
<input type="checkbox"/> Up to 72": SR24 (3) + LR24 (3)	
<input type="checkbox"/> Up to 86": LR24 (6)	
<input type="checkbox"/> Up to 104": SR24 (3) + LR24 (6)	
<input type="checkbox"/> Up to 120": LR24 (9)	
- OR -	
<input type="checkbox"/> CPRK (3): 30" - 120" (See specification for more detail.)	
Additional Options	
<input type="checkbox"/> HDK-500-JCW : High Water Table Hold Down Kit	
<input type="checkbox"/> SS : Slick Stick™ Oil Level Monitoring System*	
*Monitoring system will raise covers by 3".	

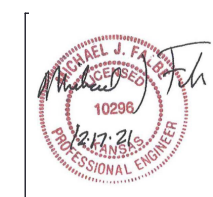

PE STAMP (For H20 Slab Design Only)

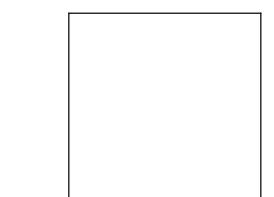

Hold Down Kit Required Unless Sealed by Kansas Professional Engineer

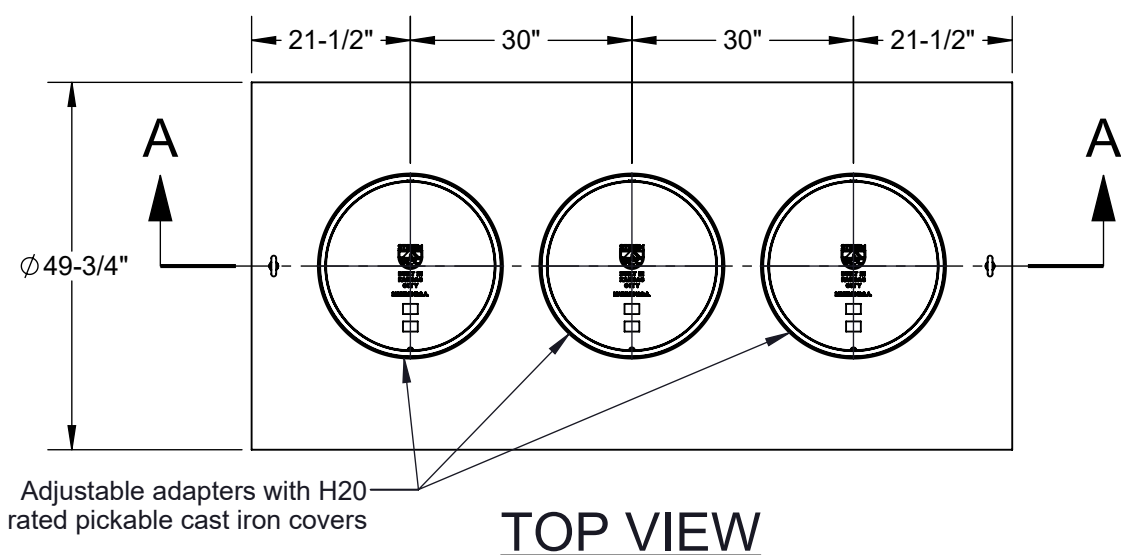

TOP VIEW

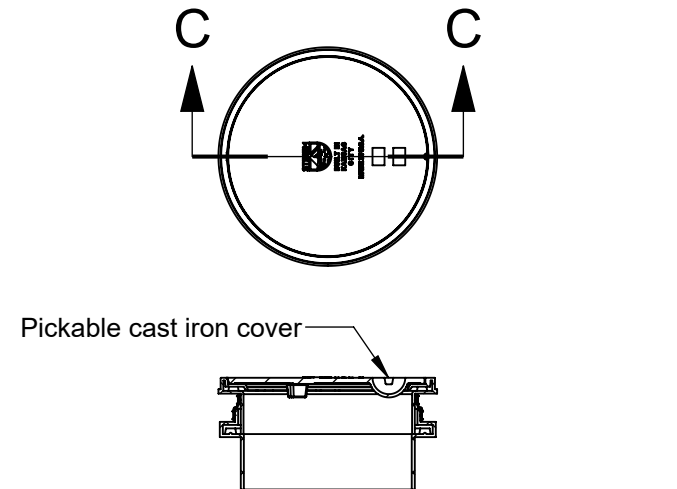

SECTION C-C

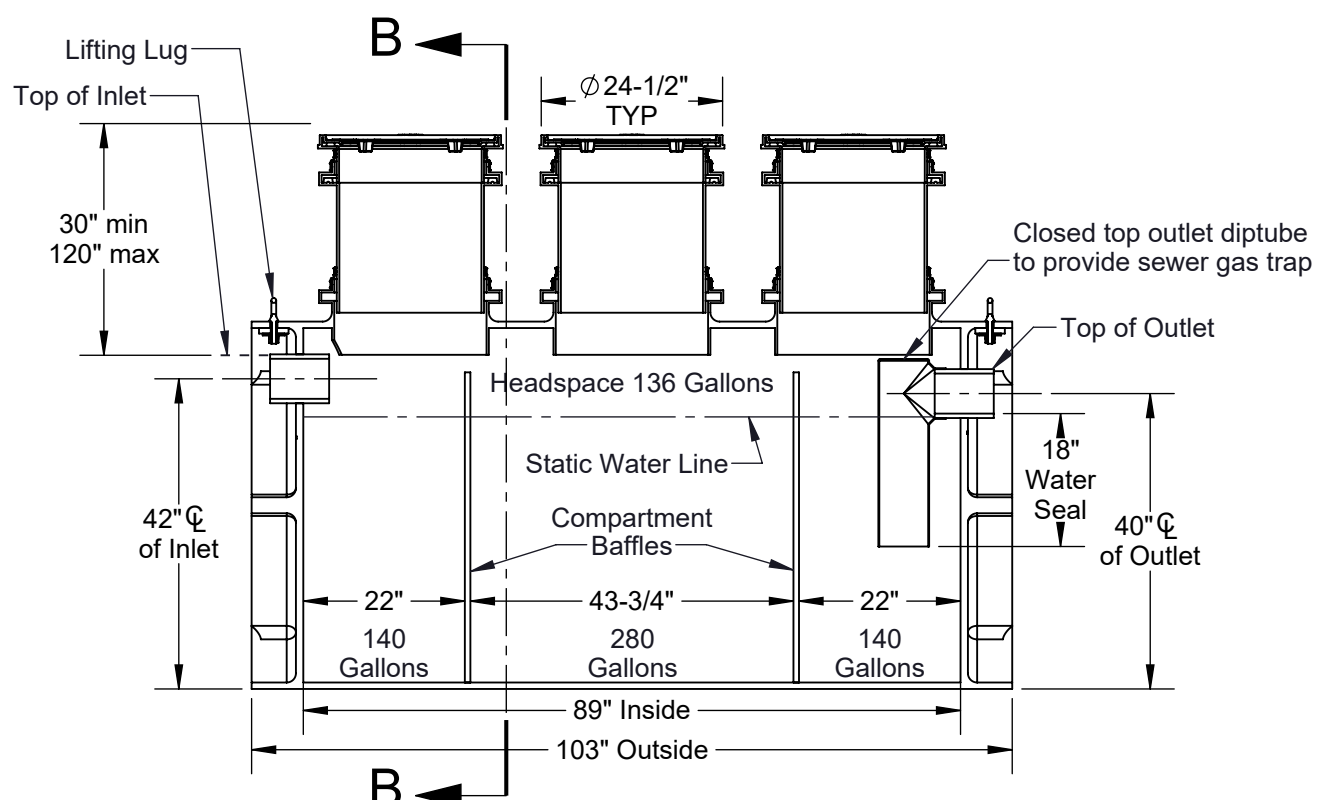

SECTION A-A

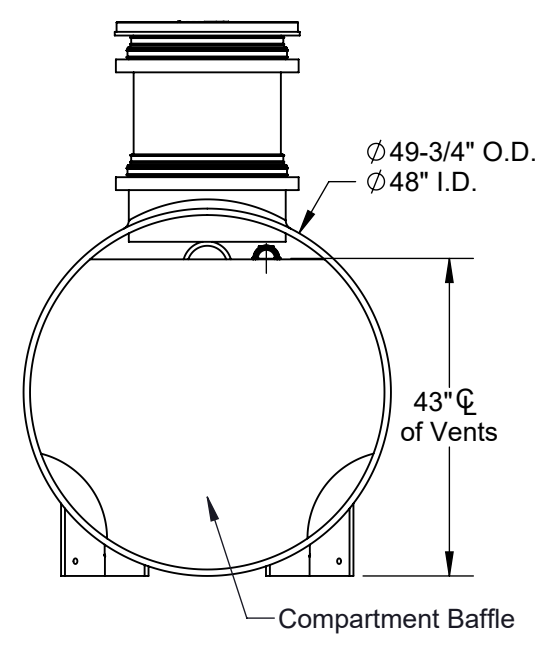

SECTION B-B

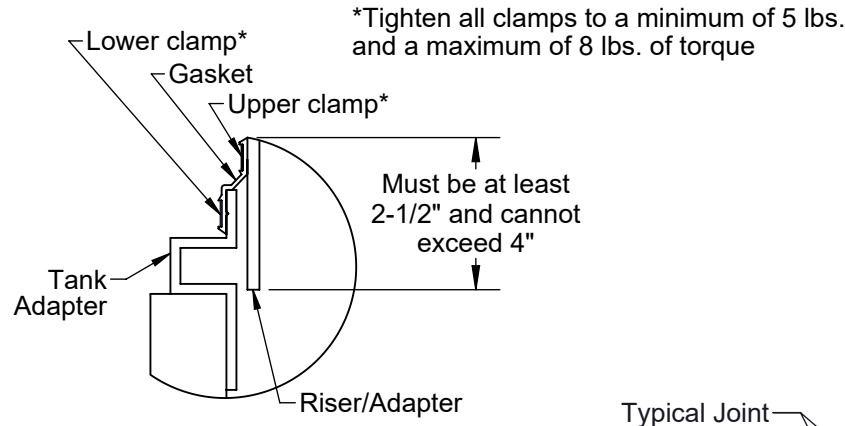

!!! ALL JCW INSPECTIONS SHALL BE REQUESTED ONLINE THROUGH THE WWW.MYGOVERNMENTONLINE.ORG PORTAL !!!

!!! REFER TO JCW PERMIT FOR JCW INSPECTION REQUIREMENTS!!!

Sand/Oil Separator Leak Test Inspection
 - The separator leak test shall be performed after the H20 slab rebar configuration has been inspected.
 - Step 1: All pipes entering/exiting the separator shall be plugged.
 - Step 2: The separator shall be filled to finish grade at the top of the riser with water.
 - Step 3: The water level shall be marked by JCW and monitored for 30 minutes to confirm the separator is not leaking.

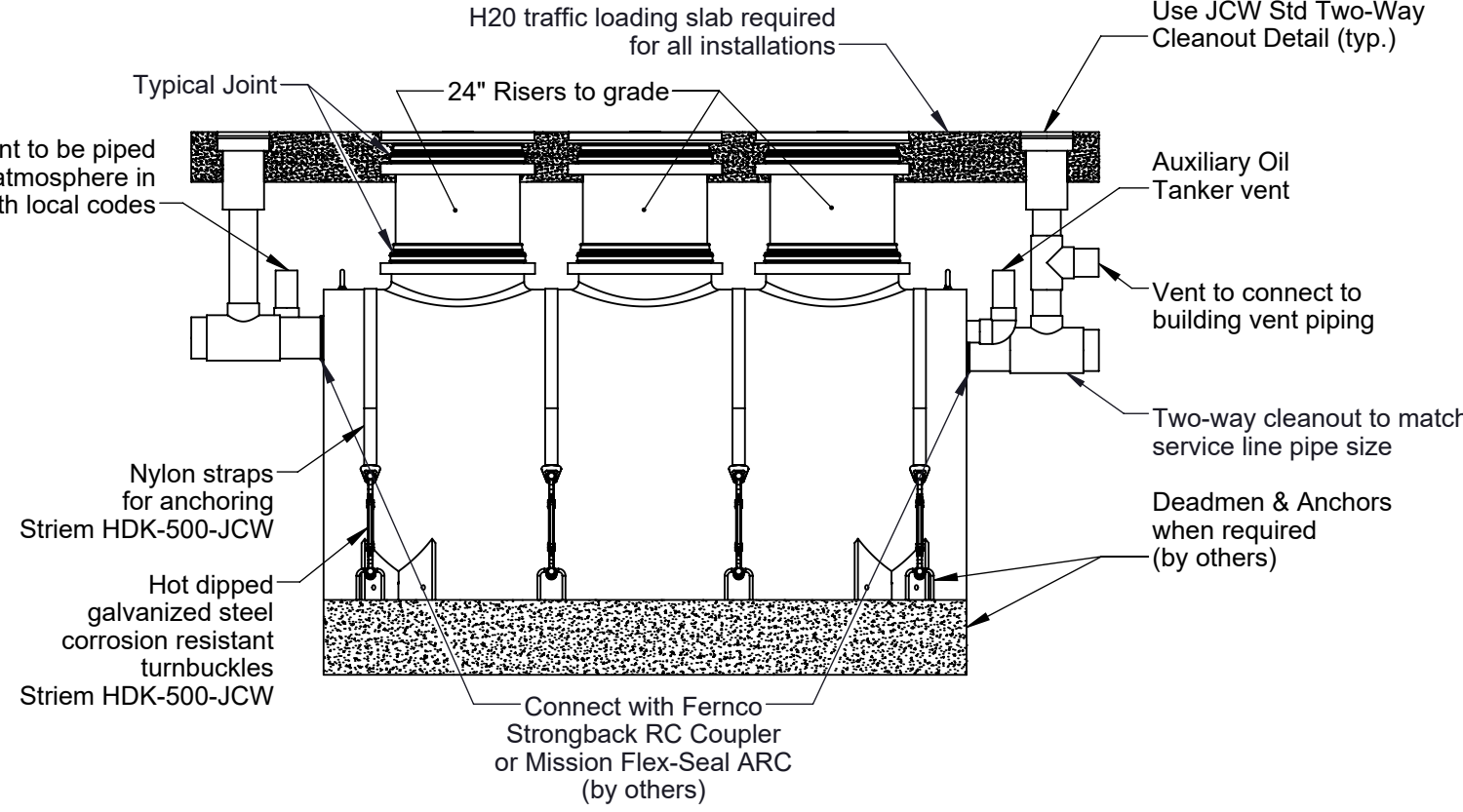

ALL PIPE EMBEDMENT IN ACCORDANCE WITH JCW STANDARDS

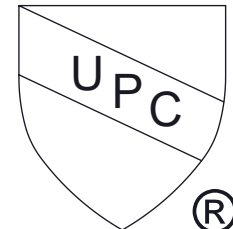

MODEL NUMBER: OT-500-JCW

DESCRIPTION:
 POLYETHYLENE OIL SEPARATOR
 314 GPM
 500 GALLON CAPACITY
 JOHNSON COUNTY WASTEWATER DETAIL

SPECIFICATION SHEET

Striem
 Kansas City, KS
 Tel: 913-222-1500
 orders@striemco.com
 www.striemco.com



Made in the U.S.A

DWG BY: ENG **DATE:** 1/20/2025 **REV:** 0

PROPRIETARY AND CONFIDENTIAL
 THE INFORMATION CONTAINED IN THIS DRAWING IS THE SOLE PROPERTY OF STRIEM, LLC.
 ANY REPRODUCTION IN PART OR AS A WHOLE WITHOUT THE WRITTEN PERMISSION OF STRIEM, LLC. IS PROHIBITED.