

SPECIFICATIONS

1. UL and CSA Listed by CentriPro: Model LAN-4.
2. Provides warning of high liquid level conditions when used with a Normally Open (N.O.) float switch. Use a Normally Closed (N.C.) switch for low level warning.
3. Single phase, 120 volt, 60 hertz power required.
4. NEMA 4X fiberglass, corrosion-resistant, weatherproof enclosure suitable for outdoor use and damp environments.
5. NEMA 4X alarm buzzer, 95dB @ 2' (0.6 meters).
6. NEMA 4X flashing alarm light on top of panel provides up to 360° signal depending on mounting.
7. Power On light inside enclosure.
8. Off/On reset switch inside enclosure.
9. Locking hasp on door.
10. Alarm buzzer and light stay on until reset even if level goes down.
11. Unit comes supplied with extra dry contact for connection to a building alarm system.
12. 10' of cable included.

ENGINEER SPECIFICATION GUIDE

Audio/visual alarm shall be as manufactured by Striem, LLC. Alarm panel to be UL and CSA listed components contained inside a NEMA 4X Enclosure. Alarm panel to be wired to a type 304 stainless steel explosion proof float switch for single level monitoring.

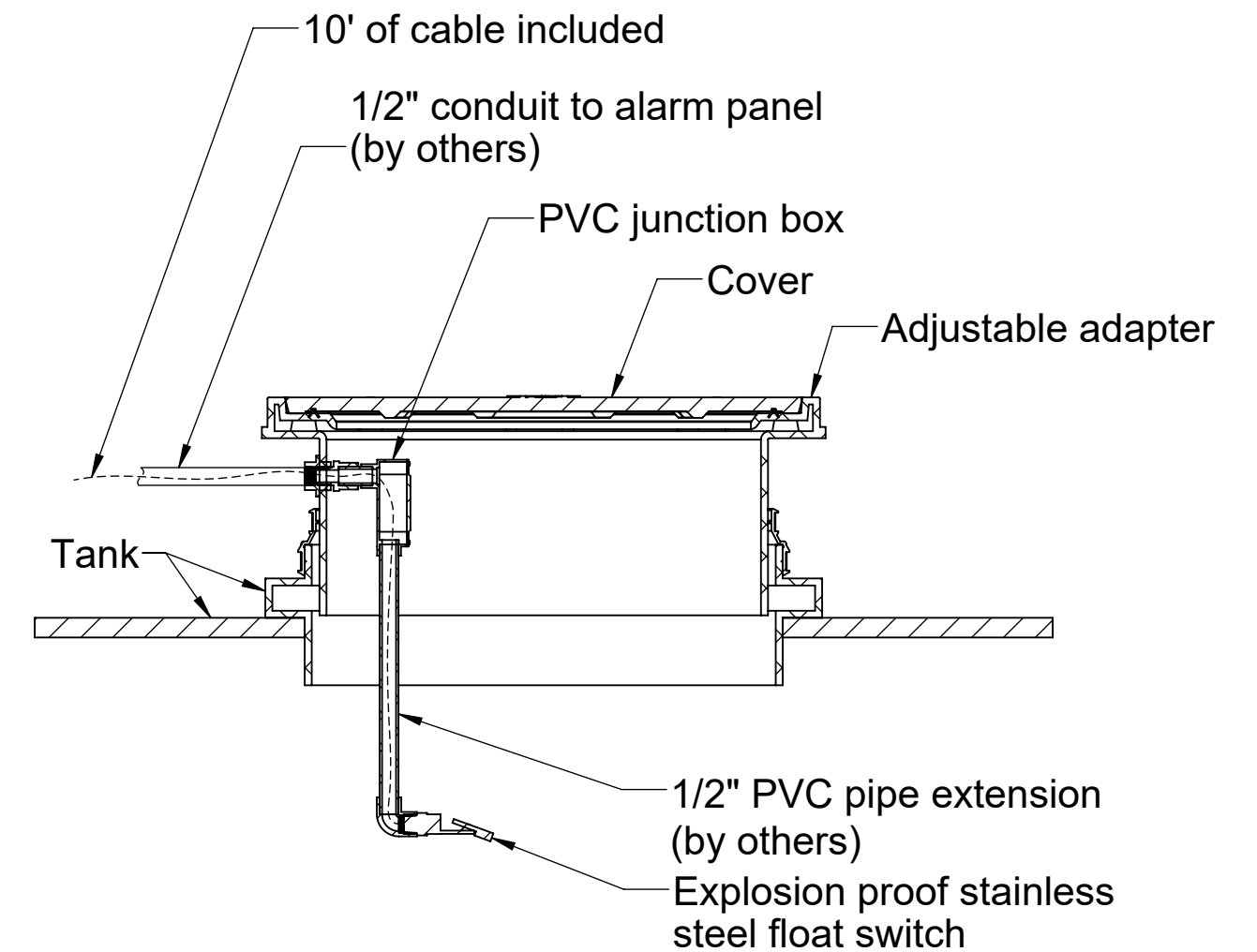
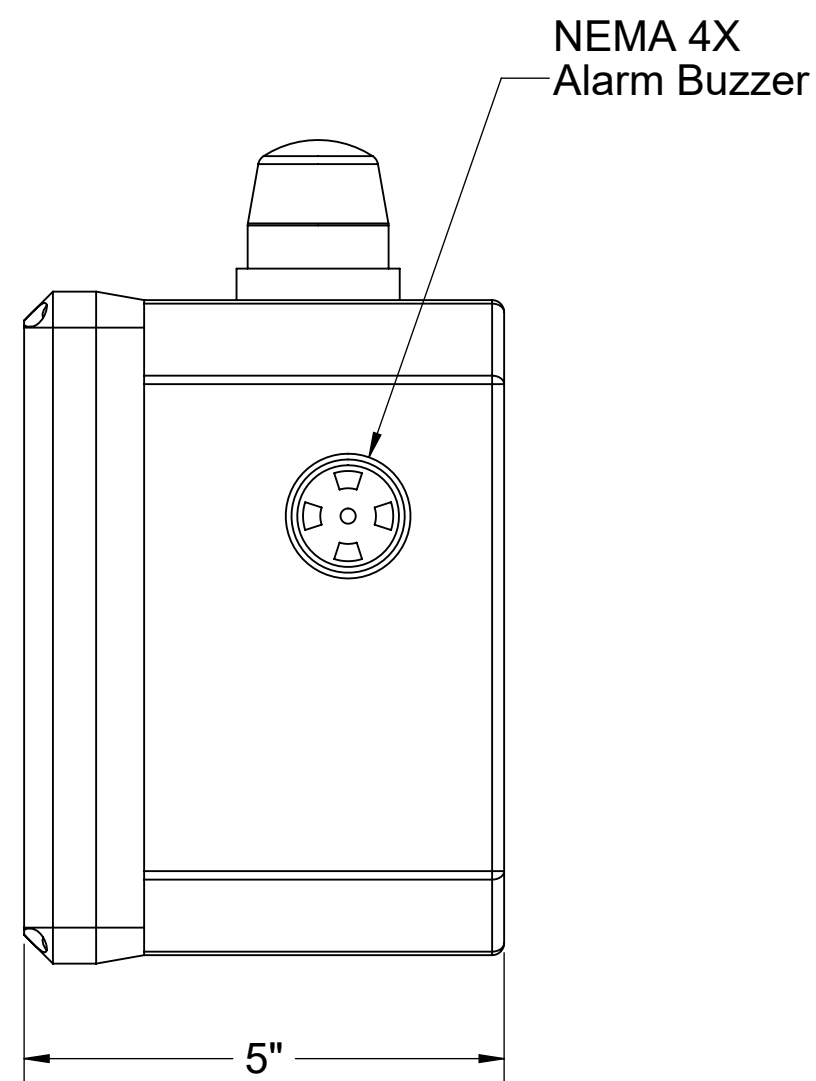
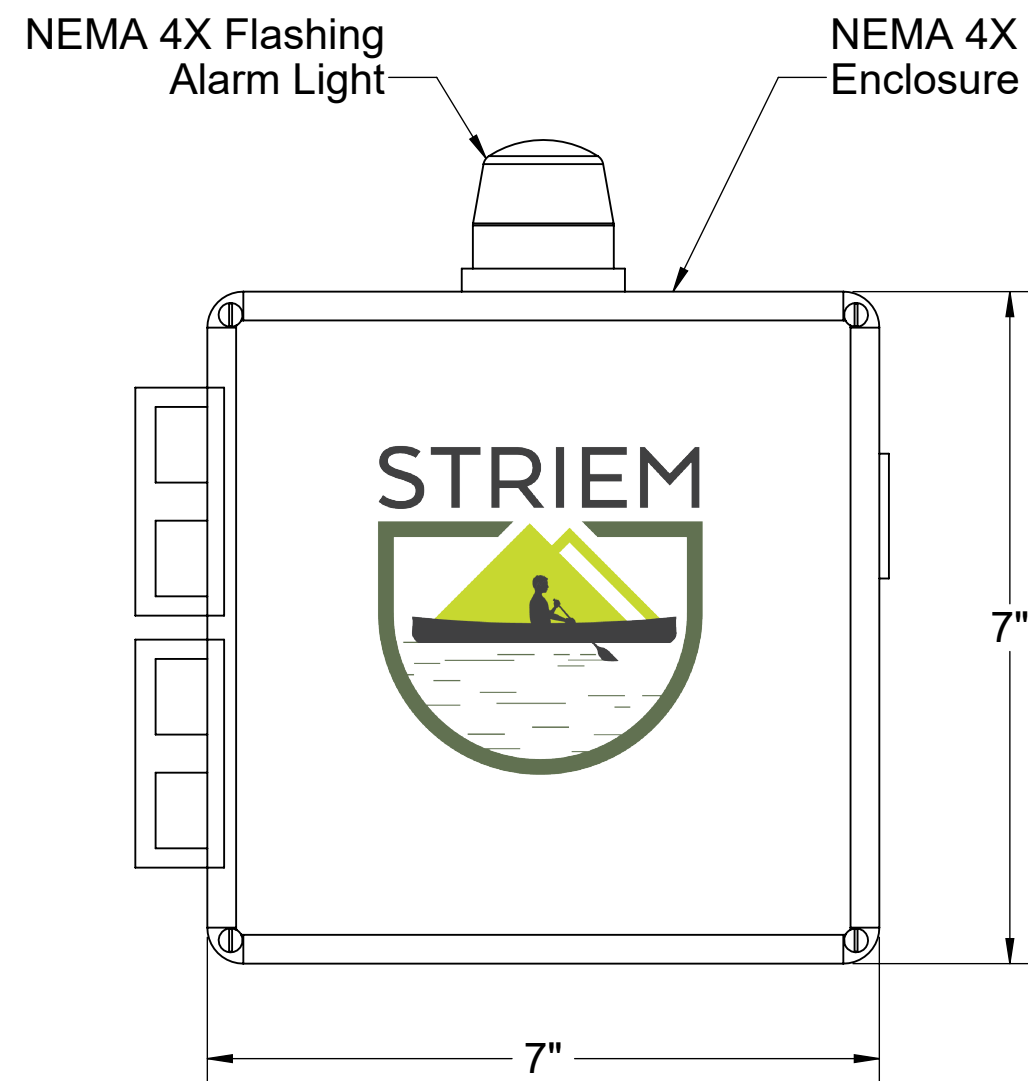

NOT TO SCALE

PO IS NON-CANCELABLE
ORDER IS NON-RETURNABLE

MODEL NUMBER: AVA-3		SPECIFICATION SHEET	
DESCRIPTION: HIGH LIQUID LEVEL ALARM WITH STAINLESS STEEL FLOAT SWITCH		Striem Kansas City, KS Tel: 913-222-1500 orders@striemco.com www.striemco.com Made in the U.S.A	
DWG BY: ENG	DATE: 4/22/2026		