

SPECIFICATIONS

1. 6" Plain End inlet/outlet shown, 3" Plain End vents standard.
2. Max flow rate: 314 GPM.
3. Liquid capacity: 2000 Gallons (267 cu. ft.).
4. Oil capacity: 638 Gallons.
5. Solids capacity: 1077 Gallons.
6. Unit weight: 2000 lbs.
7. Maximum operating temperature 140°F continuous.

NOTES

1. For gravity drainage applications only.
2. Do not use for pressure applications.
3. Capped auxiliary vent provided to allow flexibility with vent piping and design. Provided cap can be moved to unused vent location, or discarded if two chamber vents are required per local code.
4. Cover placement allows full access to tank for proper maintenance.
5. Lifting lug set for easy install.
6. Maximum burial depth: 106" from standard cover height

ENGINEER SPECIFICATION GUIDE

Striem oil separator model OT-2000 shall be lifetime guaranteed and made in the USA. Separator shall be constructed of polyethylene with 7/8" nominal wall thickness. Separator shall be manufactured for below-grade installation. Field-adjustable riser system is available as an option to bring manhole covers to grade. Separator flow rate shall be 314 GPM. Separator liquid holding capacity shall be 2000 gallons and oil capacity shall be 638 gallons. Solids capacity shall be 1077 gallons. Covers shall be H20 traffic-rated pickable cast iron. Separator shall be certified to IAPMO IGC 183-2016 and carry a UPC listing.

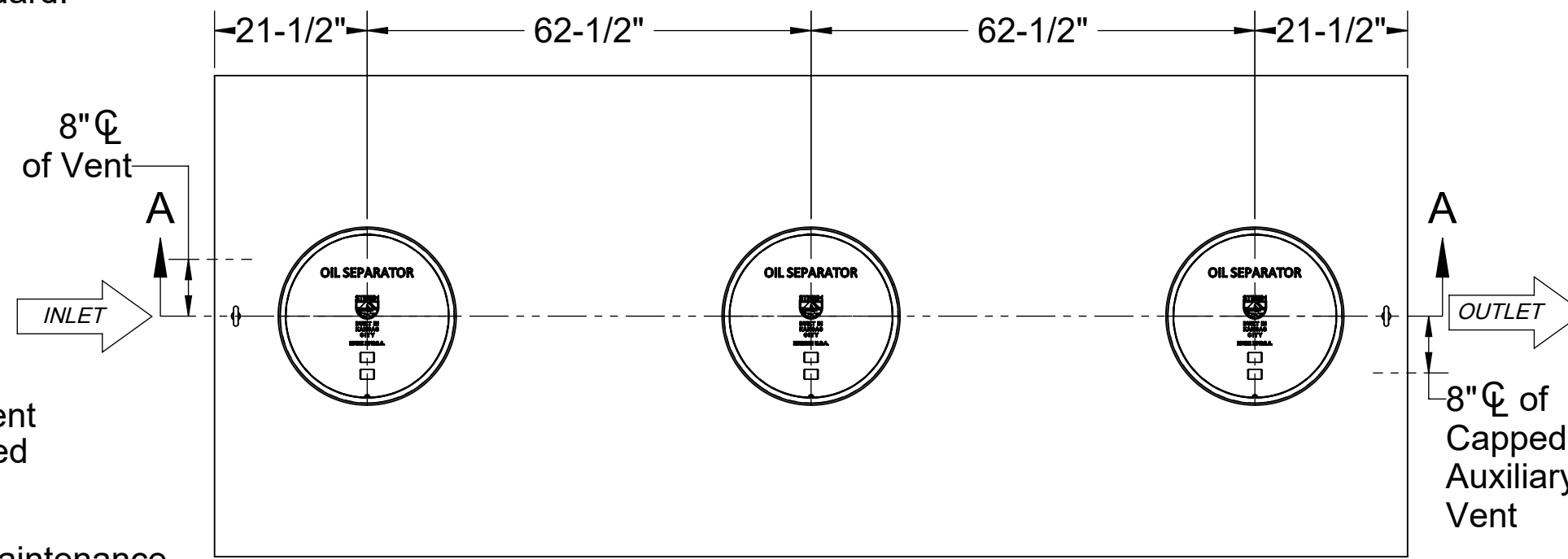

TOP VIEW

OPTIONS

Connection Options (Plain End Only)

Inlet / Outlet

- 4"
- 6"
- 8"

SELECTION REQUIRED

Riser Options

From Factory: Up to 5"

- Up to 24": **SR24** (3)
- Up to 39": **LR24** (3)
- Up to 43": **SR24** (6)
- Up to 58": **SR24** (3) + **LR24** (3)
- Up to 72": **LR24** (6)
- Up to 90": **SR24** (3) + **LR24** (6)
- Up to 106": **LR24** (9)

- OR -

- CPRK** (3): 11" - 106"
(See specification for more detail.)

Additional Options

- HDK-7**: High Water Table Hold Down Kit
 - SS**: Slick Stick™ Oil Level Monitoring System*
- *Monitoring system will raise covers by 3".

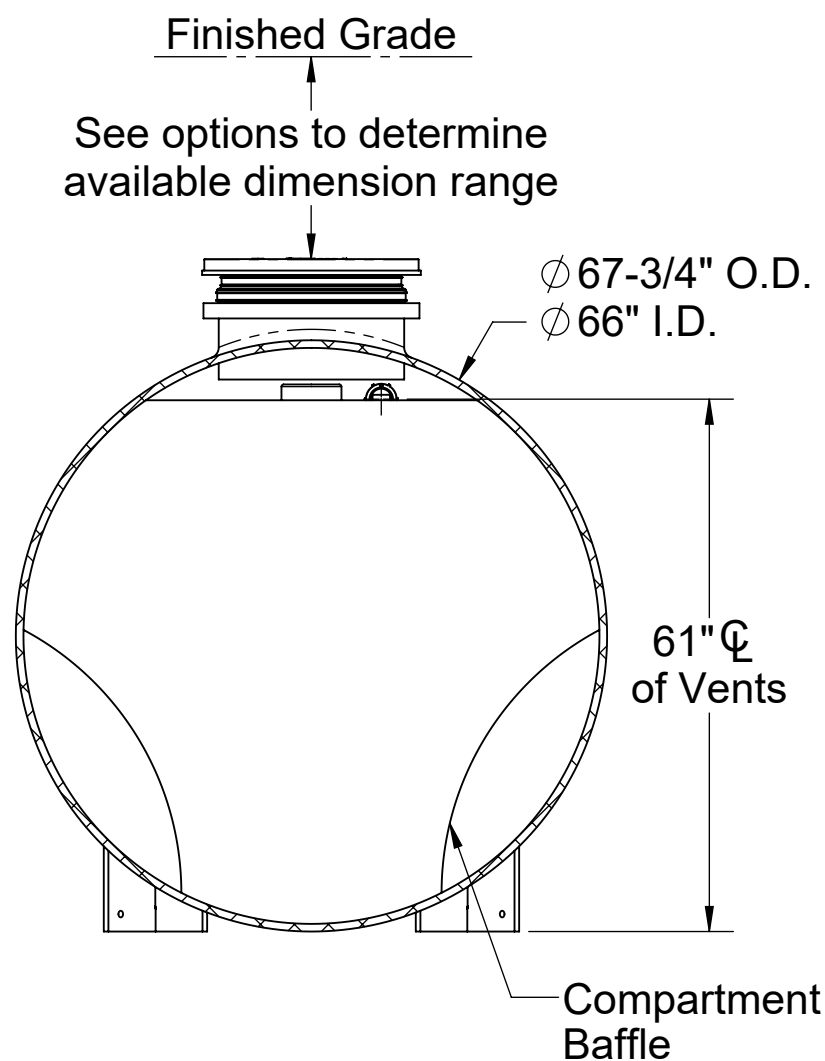

SECTION B-B

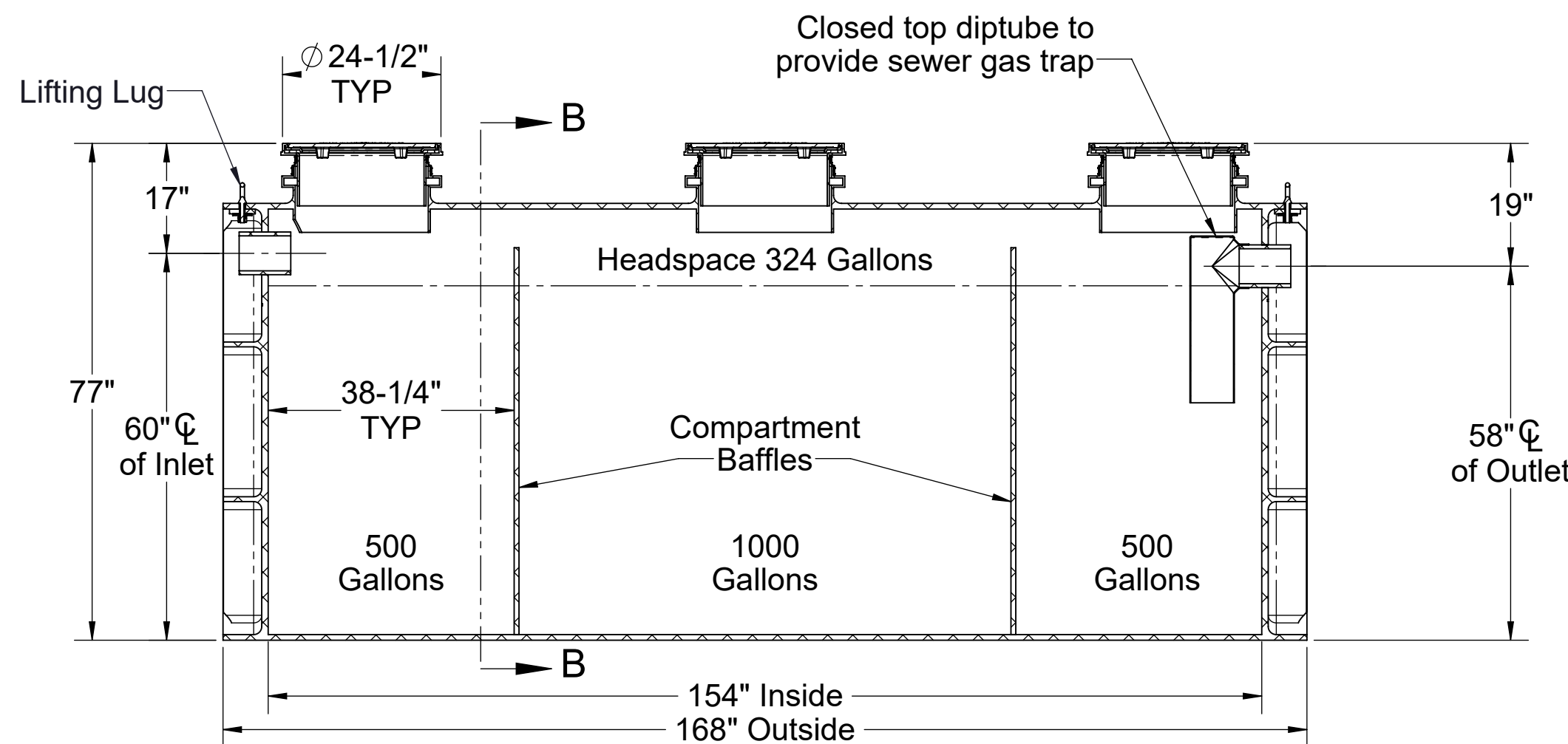

SECTION A-A

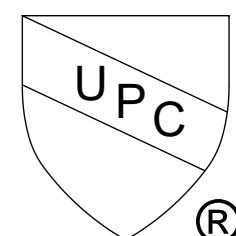
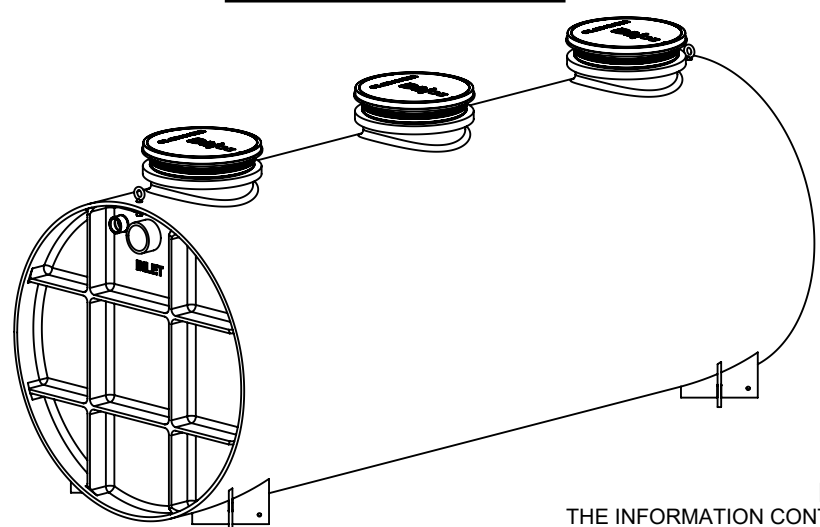

**PO IS NON-CANCELABLE
ORDER IS NON-RETURNABLE**

PROPRIETARY AND CONFIDENTIAL
THE INFORMATION CONTAINED IN THIS DRAWING IS THE SOLE PROPERTY OF STRIEM, LLC.
ANY REPRODUCTION IN PART OR AS A WHOLE WITHOUT THE WRITTEN PERMISSION OF STRIEM, LLC. IS PROHIBITED.

MODEL NUMBER: OT-2000

DESCRIPTION:
OIL TANKER™
POLYETHYLENE OIL SEPARATOR
2000 GALLON CAPACITY

DWG BY: ENG **DATE:** 5/8/2026 **REV:** 1

SPECIFICATION SHEET

Striem
Kansas City, KS
Tel: 913-222-1500
orders@striemco.com
www.striemco.com

Made in the U.S.A

