

**SPECIFICATIONS**

1. 4" Plain End outlet.
2. 1/8" per foot built-in slope.
3. Liquid Capacity: 65 Gallons.
4. Unit Weight: 135 lbs.
5. Cover Weight Limit: Above-Grade 0 lbs.; Below-Grade 450 lbs.
6. Maximum operating temperature 165°F intermittent.

**NOTES**

1. All inlet connections are field installed.
2. Filter screens equipped with  $\phi$  1/2" perforations.

**ENGINEER SPECIFICATION GUIDE**

Striem Tuff Trough model TT-10 shall be lifetime guaranteed and made in the USA. Trough shall be constructed of polyethylene with 1/4" nominal wall thickness. Trough shall have removable, corrosion-resistant primary filter screen and secondary filter screen. Trough shall be furnished with a nested cover, internally sloped floor, and suitable for above- or below-grade installation. Trough shall be equipped with a plain end molded-in outlet. Inlet connections are field installed. Maximum operating temperature 165°F intermittent. Trough shall be certified to IAPMO/ANSI/CAN Z1167 and carry a UPC listing.

**OPTIONS**

IG-3: 3" Inlet Grommet QTY: \_\_\_\_\_

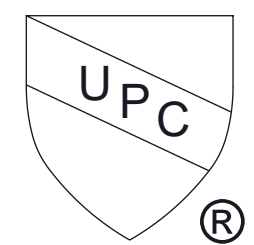
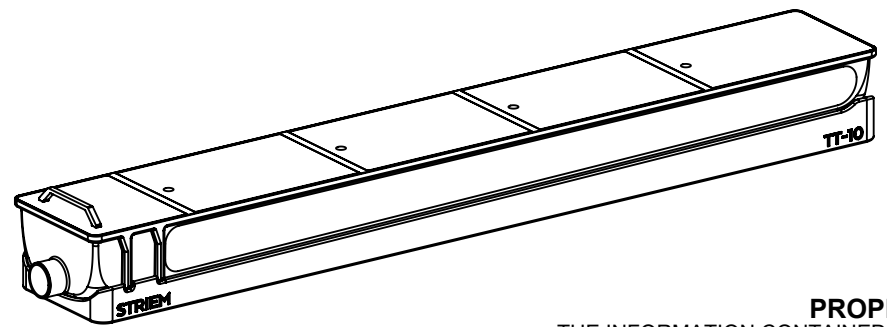
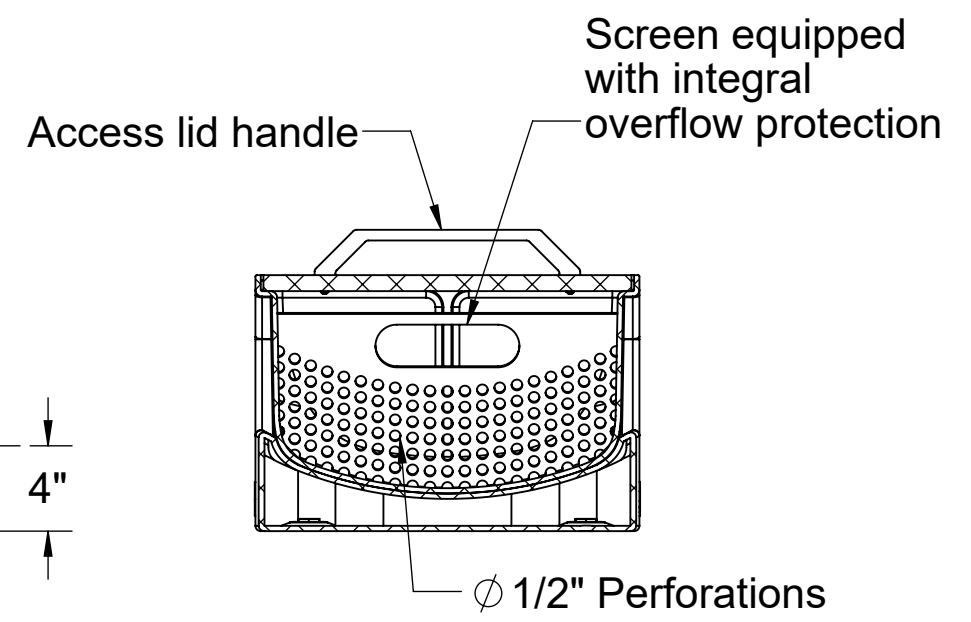
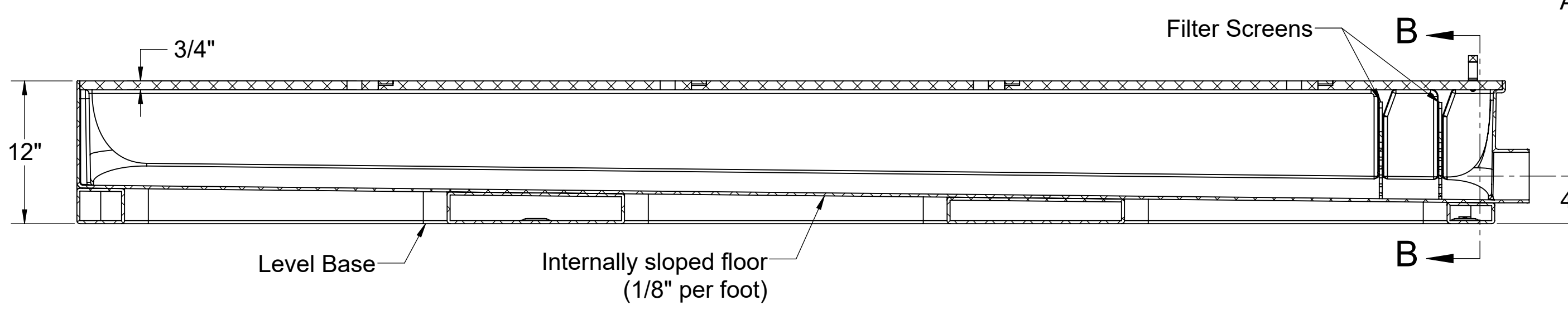
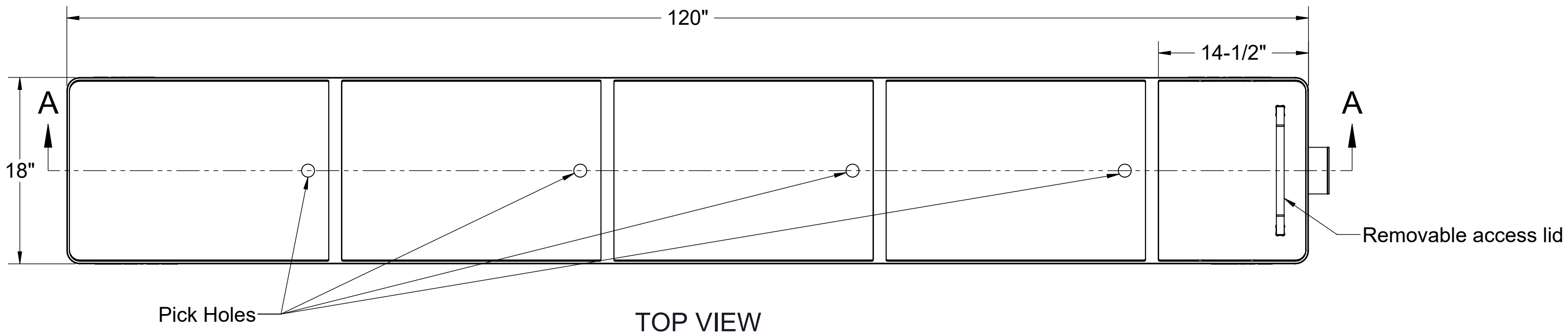
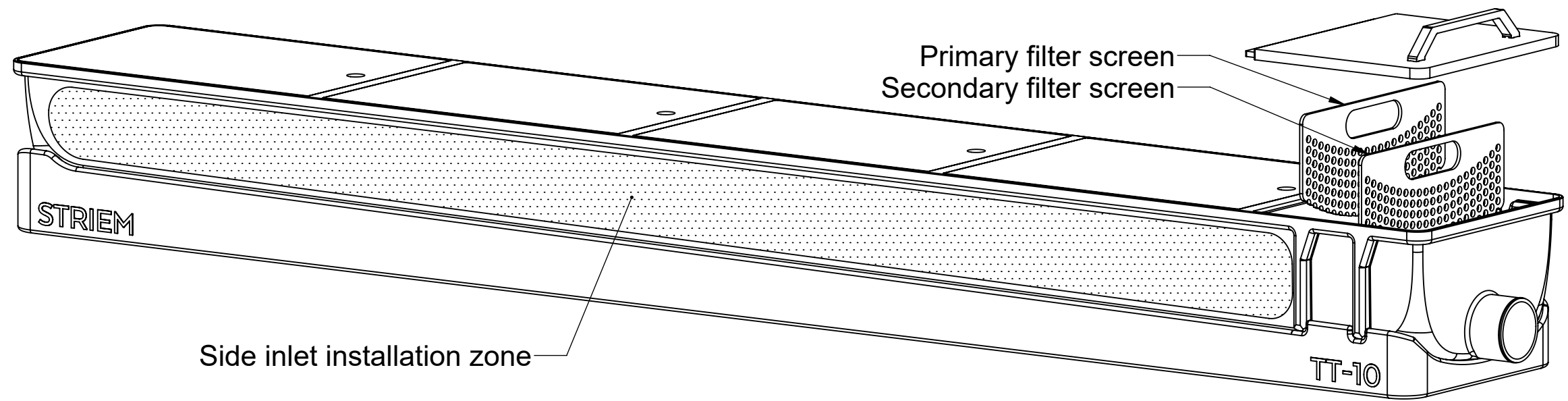

**PROPRIETARY AND CONFIDENTIAL**  
 THE INFORMATION CONTAINED IN THIS DRAWING IS THE SOLE PROPERTY OF STRIEM, LLC.  
 ANY REPRODUCTION IN PART OR AS A WHOLE WITHOUT THE WRITTEN PERMISSION OF STRIEM, LLC. IS PROHIBITED.

**MODEL NUMBER:** TT-10

**DESCRIPTION:**  
 TUFF TROUGH  
 POLYETHYLENE DRAIN TROUGH  
 65 GALLON CAPACITY

**DWG BY:** ENG    **DATE:** 5/13/2026    **REV:** 0

**SPECIFICATION SHEET**

Striem  
 Kansas City, KS  
 Tel: 913-222-1500  
 orders@striemco.com  
 www.striemco.com

Made in the U.S.A

